

IBM Storage Networking SAN512B-6



Installation, Service, and User Guide

MTM Service information: 8961-F08

IBM Storage Networking SAN512B-6



Installation, Service, and User Guide

MTM Service information: 8961-F08

Read Before Using

This product contains software that is licensed under written license agreements. Your use of such software is subject to the license agreements under which they are provided.

Before you use the information in this publication, be sure to read the general information under "Notices" on page 211.

Copyright

Portions Copyright © 2016 Brocade Communications Systems, Inc. All Rights Reserved.

© Copyright IBM Corporation 2016.

US Government Users Restricted Rights – Use, duplication or disclosure restricted by GSA ADP Schedule Contract with IBM Corp.

Contents

Figures	vii
--------------------------	------------

Tables	ix
-------------------------	-----------

Read this first	xi
----------------------------------	-----------

Getting help	xi
Accessibility features	xi
How to send your comments	xii

Safety and environmental notices	xv
---	-----------

Safety notices and labels	xv
Cautions	xv
Danger notices	xvii
Safety labels	xix
Attention notices	xx
ESD precautions	xxi
Rack safety	xxi
Rack installation	xxi
Rack relocation (19" rack)	xxiii
Product recycling and disposal	xxiii

About this document	xxv
--------------------------------------	------------

Product documents	xxv
Brocade documents	xxv
IBM and Brocade product matrix	xxvi

Chapter 1. Introducing the SAN512B-6	1
---	----------

Product features	1
Hardware components	2
Port-side view of device	3
Port-side slot numbering	5
Nonport-side view of the device	5

Chapter 2. Preparing for the Installation	7
--	----------

Safety precautions	7
Facility requirements	10
Time and items required for installation	11
Quick installation checklists	13
Items shipped	15

Chapter 3. Mounting the Device	17
---	-----------

Mounting options	17
Mounting precautions	17
Unpacking and transporting the device	19
Port-side slot numbering	20
Installing the 14U Rack Mount Kit for Four-Post Racks	20
Time and items required	20
Parts list	21
Assembling the rack hardware	22
Installing the device in the rack	25
Installing the 14U Chassis Mid-Mount Rack Kit for Two-Post Racks	27
Time and Items required	27

Parts list	28
Assembling the rack hardware	29
Installing the device in the rack	31
Removing the protective cover	33

Chapter 4. Initial Setup and Verification	35
--	-----------

Configuration and verification task guide	35
Items required	36
Providing power to the device	37
Establishing a serial connection to the device	38
Configuring the IP addresses	39
Establishing an Ethernet connection to the device	41
Setting the domain ID	41
Setting the date and time	42
Setting the time zone	43
Synchronizing local time with an external source	44
Customizing the chassis and switch name	44
Verifying the PID mode	45
Verifying installed licenses and license key	46
Verifying correct operation	46
Backing up the configuration	47
Powering down the chassis	48

Chapter 5. Installing Transceivers and Cables	49
--	-----------

Supported transceivers and cables	49
Core routing blades	50
Time and items required	52
Precautions specific to transceivers and cables	53
Cleaning the fiber-optic connectors	53
Cable management	54
Installing an SFP+ transceiver	54
Replacing an SFP+ transceiver	56
Installing a QSFP transceiver	57
Replacing a QSFP transceiver	58
Verifying the operation of new transceivers	60

Chapter 6. Monitoring the switch	61
---	-----------

Interpreting port blade LEDs	61
Interpreting extension blade LEDs	64
Interpreting control processor blade LEDs	66
Interpreting core routing blade LEDs	69
Interpreting WWN card LEDs	70
Interpreting power supply LEDs	71
Interpreting fan assembly LEDs	74
Interpreting POST and boot results	76
POST	76
Boot	77
Using monitoring commands	77
chassisShow	78
errDump and errShow	81
fanShow	82
haShow	82
historyShow	83
psShow	84

sensorShow	84
slotShow	84
sfpShow	85
switchShow	91
supportSave	92
tempShow	93
Running diagnostic tests	95

Chapter 7. Port and Extension Blades 97

Port blade overview	97
FC32-48 blade port numbering and trunking	97
Extension blade overview	99
Extension features	100
SX6 blade port numbering and trunking	101
Precautions specific to the blade	102
Faulty blade indicators	103
Time and items required for removal and installation	103
Removing a blade	103
Installing a blade	105
Verifying blade operation	106

Chapter 8. Core Routing Blades 109

Core routing blade overview	109
CR32-8 port numbering	109
ICL trunking groups	111
ICL cabling configurations	112
Precautions specific to the blade	114
Faulty core routing blade indicators	114
Time and items required	115
Removing a core routing blade	115
Installing a core routing blade	117
Verifying blade operation	118

Chapter 9. Control Processor Blades 121

Control processor blade overview	121
CPX6 port identification	122
Precautions specific to the blade	123
Blade fault indicators	123
Blade replacement task guide	124
Time and items required for replacement	125
Preparing for replacement	125
Replacing a CP blade	126
Hot-swap procedure	127
Cold-swap procedure	132
Completing the replacement	135
Verifying blade operation	136

Chapter 10. WWN Cards 137

WWN card overview	137
WWN card location and numbering	137
Precautions specific to WWN cards	138
WWN card fault indicators	138
WWN card replacement task guide	140
Time and items required for replacement	140
Using the wwnrecover utility	141
Preparing for WWN card replacement	142
Hot-swap replacement	143
Cold-swap replacement	144
Removing the WWN card and bezel	146

Configuring airflow direction on WWN cards	147
Verifying WWN card operation	149

Chapter 11. Power Supply Assemblies 151

Power supply assembly overview	151
Fan and power supply airflow	152
Power supply assembly numbering	153
Precautions specific to power supply assembly	154
Power supply assembly fault indicators	155
Power supply assembly task guide	155
Time and items required	156
Removing a power supply	156
Installing a power supply	158
Verifying power supply operation	158

Chapter 12. Fan Assemblies 161

Fan assembly overview	161
Fan and power supply airflow	162
Fan assembly numbering	164
Precautions specific to fan assemblies	164
Fan assembly fault indicators	165
Fan assembly task guide	165
Time and items required	166
Removing a fan assembly	166
Installing a fan assembly	167
Verifying fan operation	168

Chapter 13. Blade Filler Panels 169

Blade filler panel removal and replacement	169
Removing a filler panel	169
Installing a filler panel	170

Chapter 14. Cable management comb 173

Cable management comb overview	173
Time and items required for removal and installation	173
Removing cable management comb	173
Installing cable management comb	174

Chapter 15. Chassis door 175

Chassis door overview	175
Time and items required	175
Removing a chassis door	175
Installing a chassis door	176

Chapter 16. Replacing the Chassis 179

Chassis replacement overview	179
Precautions specific to chassis replacement	179
Chassis replacement task guide	180
Chassis fault indicators	181
Time and items required	181
Preparing for replacement	182
Recording critical device and SAN information	182
Disconnecting from network and fabric	185
Removing components from the chassis	186
Installing the replacement chassis	187
Installing components into the chassis	188
Synchronizing airflow direction on WWN cards	189
Downloading the configuration	189

Verifying correct operation of system	190
Reconnecting system to the network and fabric	191
Verifying correct configuration of the fabric	192
Removing the battery	193

Appendix. Product specifications. 195

Notices 211

Trademarks	212
Homologation statement	212

Electronic emission notices	212
BSMI statement (Taiwan)	213
Canadian requirements	213
CE statement	213
China ROHS	213
FCC warning (US only)	213
KCC statement (Republic of Korea)	214
Germany statement	214

Index 215

Figures

1. Port side of the SAN512B-6 (sample configuration)	4	28. CR32-8 core routing blade LEDs	69
2. Nonport side of the SAN512B-6 (sample configuration)	6	29. WWN card LEDs on bezel	71
3. Rack kit parts	22	30. Power supply LED	71
4. Left and right shelf brackets installed on rails	23	31. Fan assembly LEDs	75
5. Nut and screw locations for mounting the device	24	32. FC32-48 blade port numbering	98
6. Positioning the device for installation in a rack	26	33. SX6 extension blade port numbering	101
7. Attaching port side of device to rack rails	27	34. Removing and replacing port or extension blade	105
8. Rack kit parts	29	35. CR32-8 core routing blade port numbering	110
9. Attaching the rear tray to the rack rails	30	36. ICL cable connections (sample configuration)	112
10. Attaching the front tray to the rack rails	31	37. Core-edge ICL topology	113
11. Placing the device in the trays	32	38. Removing and installing a core routing blade	117
12. Attaching trays to the device.	33	39. CPX6 blade port identification	122
13. Removing protective cover from SAN512B-6	34	40. Removal and replacement of the control processor blade (CPX6)	128
14. QSFP transceiver with separate cable	50	41. Removal and replacement of the control processor blade (CPX6)	134
15. 2 km QSFP 16 Gbps with integrated cable	51	42. WWN card location and numbering	138
16. 2 km LWL QSFP transceiver with integrated cable	52	43. Removing and installing WWN cards	147
17. Female-to-female patch cable for QFSP connections	52	44. AC power supply assembly.	151
18. Optical transceiver extraction tool	53	45. Airflow labels	152
19. Installing an SFP+ transceiver with pull tab into blade port	55	46. Power supply assembly numbering	153
20. Installing an SFP+ transceiver with bail latch into blade port	55	47. Removing and installing power supply assembly	157
21. Replacing a SFP+ optical transceiver with pull tab into blade port	56	48. Fan assembly	162
22. Installing an SFP+ transceiver with bail latch into blade port	57	49. Airflow labels	163
23. Installing a QSFP transceiver into blade port	58	50. Fan assembly numbering	164
24. Installing a QSFP optical transceiver into blade port	59	51. Removing and installing a fan assembly	167
25. FC32-48 port blade LEDs	62	52. Removing and installing the blade filler panel	170
26. SX6 Extension blade LEDs	64	53. Removing and installing the blade filler panel	171
27. Control processor blade (CPX6)	67	54. Removing or installing cable management comb	174
		55. Removal and replacement of the chassis door	176
		56. Removing protective cover from SAN512B-6 chassis	177
		57. Removal and replacement of the chassis door	178
		58. Location of battery holder	194

Tables

1. Brocade and IBM product and model number matrix	xxvi	11. CP blade LED descriptions	67
2. Facility requirements	10	12. Core routing blade LED descriptions	70
3. Installation tasks, time, and items required	12	13. WWN card LED descriptions	71
4. Installation prerequisites	13	14. Power supply LED descriptions.	73
5. Installation and basic system configuration	13	15. Power supply LED descriptions (continued)	74
6. Configuration and verification tasks	35	16. Fan assembly LED descriptions	75
7. Example: tsTimeZone command parameter selection for the US time zones	43	17. External port to s1otShow port mapping for core blades	111
8. Supported transceivers and cables	49	18. Messages that may indicate WWN card failure	139
9. Port blade LED descriptions	62	19. RASlog messages from WWN card audit	141
10. Extension blade LED descriptions	65	20. Critical information checklist	183

Read this first

Summary of changes

This is the first edition of the IBM® Storage Networking SAN512B-6 Installation, Service, and User Guide.

Getting help

For the latest version of your product documentation, visit the IBM Publications Center at www.ibm.com/shop/publications/order. Search by form number or title.

For more information about IBM Storage Networking products, go to www.ibm.com/systems/storage/san/.

IBM Redbooks® often provide in depth information about product best practices, configurations, and more technical information. For redbooks associated with this product, enter search terms on the following Web site: www.redbook.ibm.com.

For support information for this and other IBM products, see the IBM Support Portal www.ibm.com/supportportal. Search for the product Machine type or product name.

For Fabric OS Release Notes and access to Fabric OS firmware downloads, go to the IBM Support Portal www.ibm.com/supportportal. Search for the product Machine type or product name, and then follow links for **Downloads**. More detailed instructions are available through the **Accessing firmware updates and OS documentation updates** link on the product documentation CD that is shipped with this product.

You can also contact IBM within the United States at 1-800-IBMSERV (1-800-426-7378). For support outside the United States, you can find the service number through the IBM contacts directory website at www.ibm.com/planetwide/.

Visit the IBM contact website www.ibm.com/contact for contact information for your country or region.

For information about storage and networking industry standards, see the Storage Networking Industry Association (SNIA) website at www.snia.org/.

For details regarding FICON and z Systems support, please refer to the qualification letters published on IBM ResourceLink at <https://www.ibm.com/servers/resourcelink/svc03100.nsf?OpenDatabase>

Note: New users may need to register for a free IBMid and request access.

Accessibility features

Accessibility features help users who have a disability, such as restricted mobility or limited vision, to use information technology products successfully.

Accessibility features

The following list includes the major accessibility features in this product:

- Light emitting diodes (LEDs) that flash at different rates, to represent the same information as the colors of the LEDs
- Industry-standard devices for ports and connectors
- Management of the product through management applications is available through Web and Graphical User Interface (GUI) options

Keyboard navigation

This product does not have an attached or integrated keyboard. Any keyboard navigation is provided through the management software and GUI.

Vendor software

This product includes certain vendor software that is not covered under the IBM license agreement. IBM makes no representation about the accessibility features of these products. Contact the vendor for the accessibility information about its products.

Related accessibility information

You can view the publications for this product in Adobe Portable Document Format (PDF) using the Adobe Acrobat Reader. The PDFs are provided on a product documentation CD-ROM that is packaged with the product. The CD-ROM also includes an accessible HTML version of this document.

IBM and accessibility

See the IBM Human Ability and Accessibility Center website at www.ibm.com/able/ for more information about the commitment that IBM has to accessibility.

How to send your comments

Your feedback is important in helping us provide the most accurate and high-quality information. If you have comments or suggestions for improving this document, send us your comments by email to starpubs@us.ibm.com. Be sure to include the following information:

- Exact publication title
- Form number (for example, GC27-2270-00)
- Page numbers to which you are referring

You can also mail your comments to:

International Business Machines Corporation
Information Development
Department GZW
9000 South Rita Road
Tucson, Arizona 85744-0001 U.S.A.

When you send information to IBM, you grant IBM a nonexclusive right to use or distribute the information in any way it believes appropriate without incurring any obligation to you.

Safety and environmental notices

This section contains information about:

- “Safety notices and labels”
- “Rack safety” on page xxi
- “Product recycling and disposal” on page xxiii

Safety notices and labels

When using this product, observe the danger, caution, and attention notices contained in this guide. The notices are accompanied by symbols that represent the severity of the safety condition. The danger and caution notices are listed in numerical order based on their IDs, which are displayed in parentheses, for example (D004), at the end of each notice. Use this ID to locate the translation of these danger and caution notices in the Safety Notices publication that is shipped with this product.

The following notices and statements are used in IBM documents. They are listed below in order of increasing severity of potential hazards. Follow the links for more detailed descriptions and examples of the danger, caution, and attention notices in the sections that follow.

- **Note:** These notices provide important tips, guidance, or advice.
- **“Attention notices” on page xx:** These notices indicate potential damage to programs, devices, or data.
- **“Cautions”:** These statements indicate situations that can be potentially hazardous to you.
- **“Danger notices” on page xvii:** These statements indicate situations that can be potentially lethal or extremely hazardous to you. Safety labels are also attached directly to products to warn of these situations.
- In addition to these notices, “Safety labels” on page xix may be attached to the product to warn of potential hazards.

Cautions

A Caution statement alerts you to situations that can be potentially hazardous to you or cause damage to hardware, firmware, software, or data.

General cautions



CAUTION:

Changes or modifications made to this device that are not expressly approved by the party responsible for compliance could void the user's authority to operate the equipment.



CAUTION:

Disassembling any part of the power supply and fan assembly voids the warranty and regulatory certifications. There are no user-serviceable parts inside the power supply and fan assembly.



CAUTION:

Make sure the airflow around the front, sides, and back of the device is not restricted.



CAUTION:

Ensure that the airflow direction of the power supply unit matches that of the installed fan tray. The power supplies and fan trays are clearly labeled with either a green arrow with an "E", or an orange arrow with an "I."



CAUTION:

To protect the serial port from damage, keep the cover on the port when not in use.



CAUTION:

Never leave tools inside the chassis.



CAUTION:

Use the screws specified in the procedure. Using longer screws can damage the device.

Electrical cautions



CAUTION:

Use a separate branch circuit for each power cord, which provides redundancy in case one of the circuits fails.



CAUTION:

For the NEBS-compliant installation of a device with AC or DC systems, use a ground wire of at least 2 AWG. The ground wire should have an agency-approved crimped connector (provided with the device) attached to one end, with the other end attached to building ground. The connector must be crimped with the proper tool, allowing it to be connected to both ground screws on the enclosure. Before crimping the ground wire into the provided ground lug, ensure that the bare copper wire has been cleaned and antioxidant is applied to the bare wire. In addition, anti-rotation devices or lock washers must be used with all screw connections for the grounding wire.



CAUTION:

All devices with AC power sources are intended for installation in restricted access areas only. A restricted access area is a location where access can be gained only by service personnel through the use of a special tool, lock and key, or other means of security.



CAUTION:

Before plugging a cable into any port, be sure to discharge the voltage stored on the cable by touching the electrical contacts to ground surface.



CAUTION:
Static electricity can damage the chassis and other electronic devices. To avoid damage, keep static-sensitive devices in their static-protective packages until you are ready to install them.

Cautions related to equipment weight



CAUTION:
Do not use the port cover tabs to lift the module. They are not designed to support the weight of the module, which can fall and be damaged.

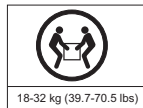

CAUTION:
To prevent damage to the chassis and components, never attempt to lift the chassis using the fan or power supply handles. These handles were not designed to support the weight of the chassis.

Danger notices

A Danger statement indicates conditions or situations that can be potentially lethal or extremely hazardous to you. Safety labels are also attached directly to products to warn of these conditions or situations.

Dangers related to equipment weight



DANGER

Use safe lifting practices when moving the product.

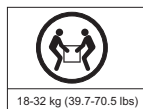

DANGER

Make sure the rack housing the device is adequately secured to prevent it from becoming unstable or falling over.

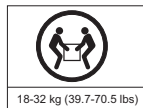

DANGER

Mount the devices you install in a rack as low as possible. Place the heaviest device at the bottom and progressively place lighter devices above.

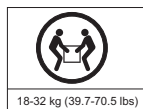

DANGER

A completely empty chassis weighs approximately 35.61 kg (78.5 lb) and requires a hydraulic or assisted lift to install it.



DANGER

A fully populated chassis weighs approximately 145.83 kg (321.5 lbs) and requires a hydraulic or assisted lift to install it.



DANGER

If a lift tool with a capacity of at least 350 lbs is not available, the director chassis must be depopulated completely before installing it into the rack. Remove the power supplies, fan modules, all of the blades, the cable management comb, and the chassis door (if equipped). Install the empty chassis into the rack following the chassis installation instructions. The weight of the empty chassis is 78.5 lbs (35.6 kg) and must be lifted by minimum 3 people. After securing the chassis to the rack, reinstall the power supplies, fan modules, and the blades and proceed with the installation.

Electrical dangers



DANGER

Make sure that the power source circuits are properly grounded, then use the power cord supplied with the device to connect it to the power source.



DANGER

Before beginning the installation, see the precautions in “Power precautions.”



DANGER

For safety reasons, the ESD wrist strap should contain a series 1 megaohm resistor.



DANGER

If the installation requires a different power cord than the one supplied with the device, make sure you use a power cord displaying the mark of the safety agency that defines the regulations for power cords in your country. The mark is your assurance that the power cord can be used safely with the device.



DANGER

Disconnect the power cord from all power sources to completely remove power from the device.



DANGER

High Touch Current. Earth connection essential before connecting supply.

Laser dangers



DANGER

All fiber-optic interfaces use Class 1 lasers.



DANGER

Use only optical transceivers that are qualified by IBM and comply with the FDA Class 1 radiation performance requirements defined in 21 CFR Subchapter I, and with IEC 825 and EN60825. Optical products that do not comply with these standards might emit light that is hazardous to the eyes.



DANGER

Laser Radiation. Do Not View Directly with Optical Instruments. Class 1M Laser Products.

Safety labels

As an added precaution, safety labels are often installed directly on products or product components to warn of potential hazards. These can be either danger or caution notices, depending upon the level of the hazard.

The actual product safety labels may differ from these sample safety labels:



DANGER

Hazardous voltage, current, or energy levels are present inside any component that has this label attached. Do not open any cover or barrier that contains this label. (L001)



DANGER

Rack-mounted devices are not to be used as a shelf or work space. (L002)

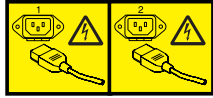

DANGER

Multiple power cords. The product might be equipped with multiple power cords. To remove all hazardous voltages, disconnect all power cords. (L003)



DANGER

Hazardous voltage present. Voltages present constitute a shock hazard, which can cause severe injury or death. (L004)



CAUTION:

Hazardous moving parts nearby. (L008)

Attention notices

An attention notice indicates the possibility of damage to a program, device, or system, or to data. An exclamation point symbol may accompany an attention notice, but is not required. A sample attention notice follows:

Attention: Do not bend a fibre cable to a radius less than 5 cm (2 in.); you can damage the cable. Tie wraps are not recommended for optical cables because they can be easily overtightened, causing damage to the cable.

ESD precautions

Attention: Many of the field replaceable units (FRUs) are sensitive to electrostatic discharge (ESD), and can potentially be damaged by improper handling. When working with any FRU, use correct ESD precautions:

- Attach ground to the indicated area on the chassis
- Wear a wrist grounding strap connected to chassis ground (if the switch is plugged in) or a bench ground.

Note: For safety reasons, the ESD wrist strap should contain a series 1 megaohm resistor.

- Store ESD-sensitive components in antistatic packaging

Rack safety

Rack installation

DANGER

Observe the following precautions when working on or around your IT rack system:

- Heavy equipment—personal injury or equipment damage might result if mishandled.
- Always lower the leveling pads on the rack cabinet.
- Always install stabilizer brackets on the rack cabinet.
- To avoid hazardous conditions due to uneven mechanical loading, always install the heaviest devices in the bottom of the rack cabinet. Always install servers and optional devices starting from the bottom of the rack cabinet.
- Rack-mounted devices are not to be used as shelves or work spaces. Do not place objects on top of rack-mounted devices.



- Each rack cabinet might have more than one power cord. Be sure to disconnect all power cords in the rack cabinet when directed to disconnect power during servicing.
- Connect all devices installed in a rack cabinet to power devices installed in the same rack cabinet. Do not plug a power cord from a device installed in one rack cabinet into a power device installed in a different rack cabinet.
- An electrical outlet that is not correctly wired could place hazardous voltage on the metal parts of the system or the devices that attach to the system. It is the responsibility of the customer to ensure that the outlet is correctly wired and grounded to prevent an electrical shock.

(R001 part 1 of 2)

CAUTION:

- Do not install a unit in a rack where the internal rack ambient temperatures will exceed the manufacturer's recommended ambient temperature for all your rack-mounted devices.
- Do not install a unit in a rack where the air flow is compromised. Ensure that air flow is not blocked or reduced on any side, front, or back of a unit used for air flow through the unit.
- Consideration should be given to the connection of the equipment to the supply circuit so that overloading of the circuits does not compromise the supply wiring or overcurrent protection. To provide the correct power connection to a rack, refer to the rating labels located on the equipment in the rack to determine the total power requirement of the supply circuit.
- *(For sliding drawers)* Do not pull out or install any drawer or feature if the rack stabilizer brackets are not attached to the rack. Do not pull out more than one drawer at a time. The rack might become unstable if you pull out more than one drawer at a time.
- *(For fixed drawers)* This drawer is a fixed drawer and must not be moved for servicing unless specified by the manufacturer. Attempting to move the drawer partially or completely out of the rack might cause the rack to become unstable or cause the drawer to fall out of the rack.

(R001 part 2 of 2)

Rack relocation (19" rack)

CAUTION:

Removing components from the upper positions in the rack cabinet improves rack stability during relocation. Follow these general guidelines whenever you relocate a populated rack cabinet within a room or building:

- Reduce the weight of the rack cabinet by removing equipment starting at the top of the rack cabinet. When possible, restore the rack cabinet to the configuration of the rack cabinet as you received it. If this configuration is not known, you must complete these steps:
 - Remove all devices in the 32U position and above.
 - Ensure that the heaviest devices are installed in the bottom of the rack cabinet.
 - Ensure that there are no empty U-levels between devices installed in the rack cabinet below the 32U level.
 - If the rack cabinet you are relocating is part of a suite of rack cabinets, detach the rack cabinet from the suite.
 - Inspect the route that you plan to take when moving the rack to eliminate potential hazards.
 - Verify that the route that you choose can support the weight of the loaded rack cabinet. Refer to the documentation that came with your rack cabinet for the weight of a loaded rack cabinet.
 - Verify that all door openings are at least 760 x 2030 mm (30 x 80 in.).
 - Ensure that all devices, shelves, drawers, doors, and cables are secure.
 - Ensure that the four leveling pads are raised to their highest position.
 - Ensure that there is no stabilizer bracket installed on the rack cabinet during movement.
 - Do not use a ramp inclined at more than 10 degrees.
 - Once the rack cabinet is in the new location, do the following:
 - Lower the four leveling pads.
 - Install stabilizer brackets on the rack cabinet.
 - If you removed any devices from the rack cabinet, repopulate the rack cabinet from the lowest position to the highest position.
 - If a long distance relocation is required, restore the rack cabinet to the configuration of the rack cabinet as you received it. Pack the rack cabinet in the original packaging material, or equivalent. Also, lower the leveling pads to raise the casters off of the pallet and bolt the rack cabinet to the pallet.

(R002)

Product recycling and disposal

Refer to the *IBM Systems Environmental Notices and User Guide (Z125-5823)* for translated environmental statements and information regarding product recycling and disposal. This document may be provided either in printed version or on the product documentation CD. A more current version may be available through this link ftp://public.dhe.ibm.com/systems/support/warranty/envnotices/environmental_notices_and_user_guide.pdf.

About this document

This document is intended for use by systems administrators and technicians experienced with networking, Fibre Channel, and storage area network (SAN) technologies. It describes how to install, service, and use the IBM Storage Networking SAN512B-6 (machine type-models 8961-F08 Switch). Throughout this document, the product is referred to as the *SAN512B-6*, or simply the *switch*.

This document has been created to include information specific to SAN512B-6 switches running on Fabric OS version 8.0.1 or later. This document does not support all Fabric OS versions. It is specific to Fabric OS v8.0.1 or later. Refer to the Fabric OS Release Notes for more information.

Product documents

The following documents contain information related to this product. The documentation may be printed material or may be on the documentation CD that is shipped with the product.

- *IBM Storage Networking SAN512B-6 Installation, Service, and User Guide, SC27-8966* (this document)
- *IBM Storage Networking SAN512B-6 Quick Start Guide, GI13-4550*
- Safety Notices
- *IBM Systems Environmental Notices and User Guide, Z125-5823*
- *Warranty Information, 45W6626*

Newer versions of product documentation may be available through the IBM Publications Center website www.ibm.com/shop/publications/order. Search by publication title or publication number.

Newer versions may also be available through the IBM Support Portal www.ibm.com/supportportal. Enter your product machine type (8961) or product name in the search field, and then select **Documentation** from the displayed page.

Brocade documents

IBM b-type switches use software licensed from Brocade Communications Systems, Inc. You can find information related to the software that supports the switch in the following documents on the CD-ROM supplied with this product:

Brocade Fabric OS

- *EZSwitchSetup Administrator's Guide*
- *Fabric OS Administrator's Guide*
- *Fabric OS Command Reference Manual*
- *Fabric OS MIB Reference Manual*
- *Fabric OS Message Reference Manual*
- *Fabric OS Troubleshooting and Diagnostics Guide*

Brocade Fabric OS optional features

- *Fabric Watch Administrator's Guide*

IBM and Brocade product matrix

The product matrix provides a cross-reference between the comparable IBM and Brocade product models.

When you use any of the Brocade documents, such as Fabric Operating System (FOS) publications, you will notice that the model numbers reflect the corresponding Brocade products. Table 1 provides a product matrix to correlate the Brocade products and models to the IBM product names and machine types and model numbers. Products withdrawn from marketing are not listed.

Table 1. Brocade and IBM product and model number matrix

Brocade product name	IBM product name	IBM machine type and model number
Brocade G620	SAN64B-6	8900 Models F64 and N64
Brocade X6-4 Director	SAN256B-6	8961 Models F04
Brocade X6-8 Director	SAN512B-6	8961 Models F08
Brocade 6520	SAN96B-5	2498 Models F96 and N96
Brocade 6505	SAN24B-5	2498 Model X24
Brocade 6510	SAN48B-5	2498 Model F48
Brocade DCX 8510-4	SAN384B-2	2499 Model 416
Brocade DCX 8510-8	SAN768B-2	2499 Model 816
Brocade 7800	SAN06B-R	2498 Model R06
Brocade 7840	SAN42B-R	2498 Model R42
Brocade 300	SAN24B-4	2498 Models B24 and 24E

Chapter 1. Introducing the SAN512B-6

This chapter provides the following information:

- “Product features”
- “Hardware components” on page 2
- “Port-side view of device” on page 3
- “Port-side slot numbering” on page 5
- “Nonport-side view of the device” on page 5

Product features

Key product features for this device include the following:

- Redundant and hot-swappable SFP, SFP+, SFP28, and QSFP+ transceivers; port, extension, control processor (CP) and core routing (CR) blades; power supply assemblies, fan assemblies, and WWN cards that enable a high availability platform and allow nondisruptive software upgrades for mission-critical SAN applications.
- Up to 384 32-Gbps external ports and 32 4x32-Gbps QSFP (ICL) ports in a single chassis, enabling high density SAN configurations with reduced footprint.
- Up to 192 32-Gbps external ports and 16 4x32-Gbps QSFP (ICL) ports in a single chassis, enabling high density SAN configurations with reduced footprint.
- Support for 48 4-, 8-, 16-, and 32-Gbps autosensing Fibre Channel ports on FC32-48 port blades. Trunking technology groups up to eight ports to create high performance 256-Gbps ISL trunks between switches using 32-Gbps ports.
- 10-Gbps FC-type SFPs on FC32-48 port blades and 10-GbE SFPs on the SX6 application blades. The two types of SFPs are not interchangeable. The 10-Gbps transceivers can be used for any port on the FC32-48 port blades.
- Support for 16 Fibre Channel ports supporting 4-, 8-, 16-, and 32-Gbps; 16 GbE ports supporting 1 or 10 Gbps; and two GbE ports supporting 40 Gbps on SX6 extension blades. Trunking technology groups up to eight ports to create high performance 256-Gbps ISL trunks between switches using 32-Gbps ports.
- Support for FC quad SFP (QSFP) ports supporting 4x16 Gbps and 4x32 Gbps on core CR blades. Up to nine chassis in a full-mesh topology and 12 chassis in a core-to-edge topology can be connected using these Fibre Channel ports for inter-chassis links (ICLs).
- Universal ports that self-configure as E_Ports, F_Ports, EX_Ports, M_Ports (mirror ports), and FICON ports. The 10-Gbps ports on the port blade can function as E_Ports only.
- ClearLink Diagnostic port (D_Port) functionality on Fibre Channel ports.
- Data compression capabilities through the port blades when ports are configured as ISLs.
- The SX6 blades perform as extension platforms to support Fibre Channel (FC) and FICON data flows and IP-based storage data flows over an IP WAN.

Hardware components

The device has a modular and scalable mechanical construction that allows a wide range of flexibility in installation, fabric design, and maintenance. The device can be mounted with the cables facing either the front or the rear of the equipment rack, and consists of the following:

- Up to eight slots for hot-swappable port blade assemblies, providing up to 384 32-Gbps Fibre Channel ports.
- Two half-size slots for control processor (CP) blades:
 - A single active CP blade can control all the ports in the device.
 - The standby CP blade assumes control of the device if the active CP blade fails.
- Two slots for core routing (CR) blades:
 - CR blade interconnects all port blades.
 - Up to 32 4x32-Gbps QSFP (ICL) ports.
 - ICL ports allow interconnection with neighboring chassis
 - Both CR blades are active.
- Up to four slots for modular, hot-swappable 34-port SX6 extension blades. Blades provide 16 32-Gbps Fibre Channel (FC) ports supporting 8, 16, and 32 Gbps or 16 16-Gbps FC ports supporting 4, 8, and 16 Gbps; 16 GbE ports supporting 1 or 10 Gbps; and 2 GbE ports supporting 40 Gbps. Extension blades enable long-distance communication over an existing IP infrastructure.
- Modular, hot-swappable field-replaceable units (FRUs):
 - Three fan assemblies, available with nonport-side intake (NPI) or nonport-side exhaust (NPE) airflow.
 - Up to four power supply assemblies, available with nonport-side intake (NPI) or nonport-side exhaust (NPE) airflow. The power supplies are approved for 100–120 VAC and 200–240 VAC.
 - At 100–120 VAC (nominal): Four power supply assemblies are required for high availability. Refer to the "Power requirements" section in the "Product specifications," on page 195 specific high availability requirements.
 - 200–240 VAC (nominal) is recommended for efficiency. Depending on quantity ordered, three or four power supply assemblies are provided. Refer to the "Power requirements" section in the "Product specifications," on page 195 for specific high-availability requirements.
 - Redundant AC primary power connections ensure high availability. Each power supply assembly has its own connector, so four is the number of primary power connections for optimum efficiency and redundancy.
 - Two World Wide Name (WWN) cards located on the nonport side of the device behind the WWN card bezel.
 - Blades use small form-factor pluggable (SFP+ and QSFP+) optical transceivers.
 - The 10-Gbps speed must be manually set and requires special 10-Gbps FC SFP+ transceivers.
 - The 32-Gbps SFP+ transceivers support speeds of 8, 16, and 32 Gbps.
 - The 16-Gbps SFP+ transceivers support speeds of 4, 8, and 16 Gbps.
 - The 4x32-Gbps QSFP+ transceivers on the core routing blades provide four 32-Gbps inter-chassis links (ICL) clustered in a single quad connector and cable.

- The 4x16-Gbps QSFP+ transceivers on the core routing blades provide four 16-Gbps inter-chassis links (ICL) clustered in a single quad connector and cable).
- Chassis door. This door must be installed to meet EMI compliance certification.
- A cable management comb. These install on the chassis below the blades for cable management.

Port-side view of device

The following illustration shows the port-side view of the SAN512B-6 with installed blades identified. Note that SX6 extension blades are not shown in the following illustration, but would install in the same slots as the FC32-48 port blade. A maximum of four SX6 blades are supported.

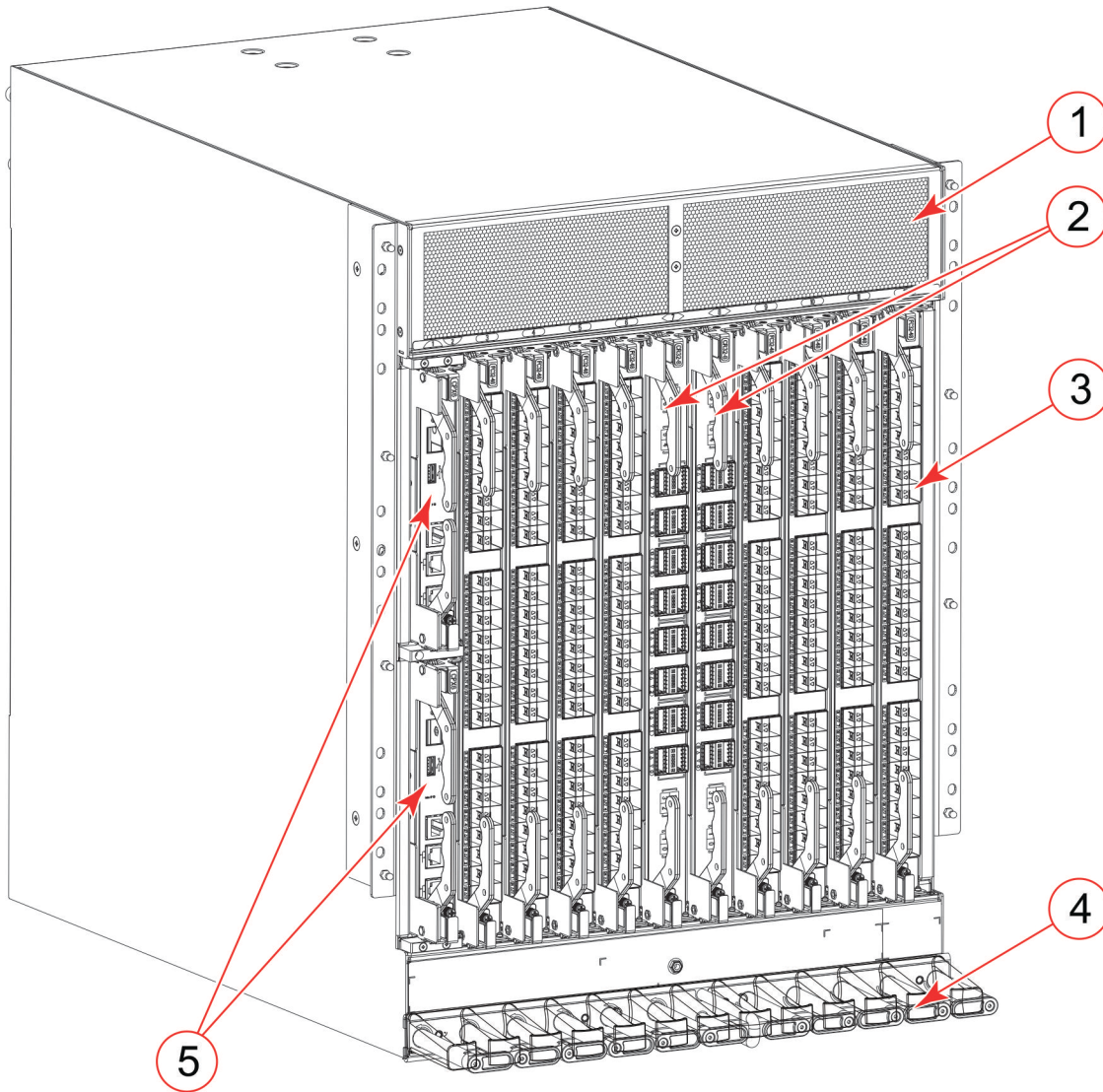

- 1 - Air vent
- 2 - Core routing blades (CR32-8)
- 3 - Port blades (FC32-48)
- 4 - Cable management comb
- 5 - Control processor blades (CPX6) – slot 1 (upper), slot 2 (lower)

Figure 1. Port side of the SAN512B-6 (sample configuration)

Notes:

- Depending on the fans and power supplies installed, airflow can be from the port side to the nonport side of chassis or from the nonport side to the port side of the chassis.
- Do not attempt to lift the chassis by the protective cover attached over the air vents at the top of the chassis.

Port-side slot numbering

The SAN512B-6 contains 10 full-height slots and two half-height slots, for a total of 12 slots. Facing the port side of the device, the half-height slots are on the left, numbered 1 (top slot) and 2 (bottom slot). The remaining full-height slots are numbered 3 through 12, counting from left to right of chassis.

Slots contain guide pins and connectors designed for specific blade types. Only install the control processor (CP), core routing (CR), port, and extension blades into slot numbers as follows:

- Slots 1– 2 are restricted to CP blades. Note that the blade installed in slot 1 will be designated as CP0, while the blade in slot 2 will be designated as CP1 in CLI command and message output.
- Slots 3–6 and slots 9–12 are restricted to port and extension blades.
- Slots 7– 8 are restricted to CR32-8 blades.

Nonport-side view of the device

The following illustration shows the nonport-side view of the SAN512B-6 with all fan and power supply assemblies installed.

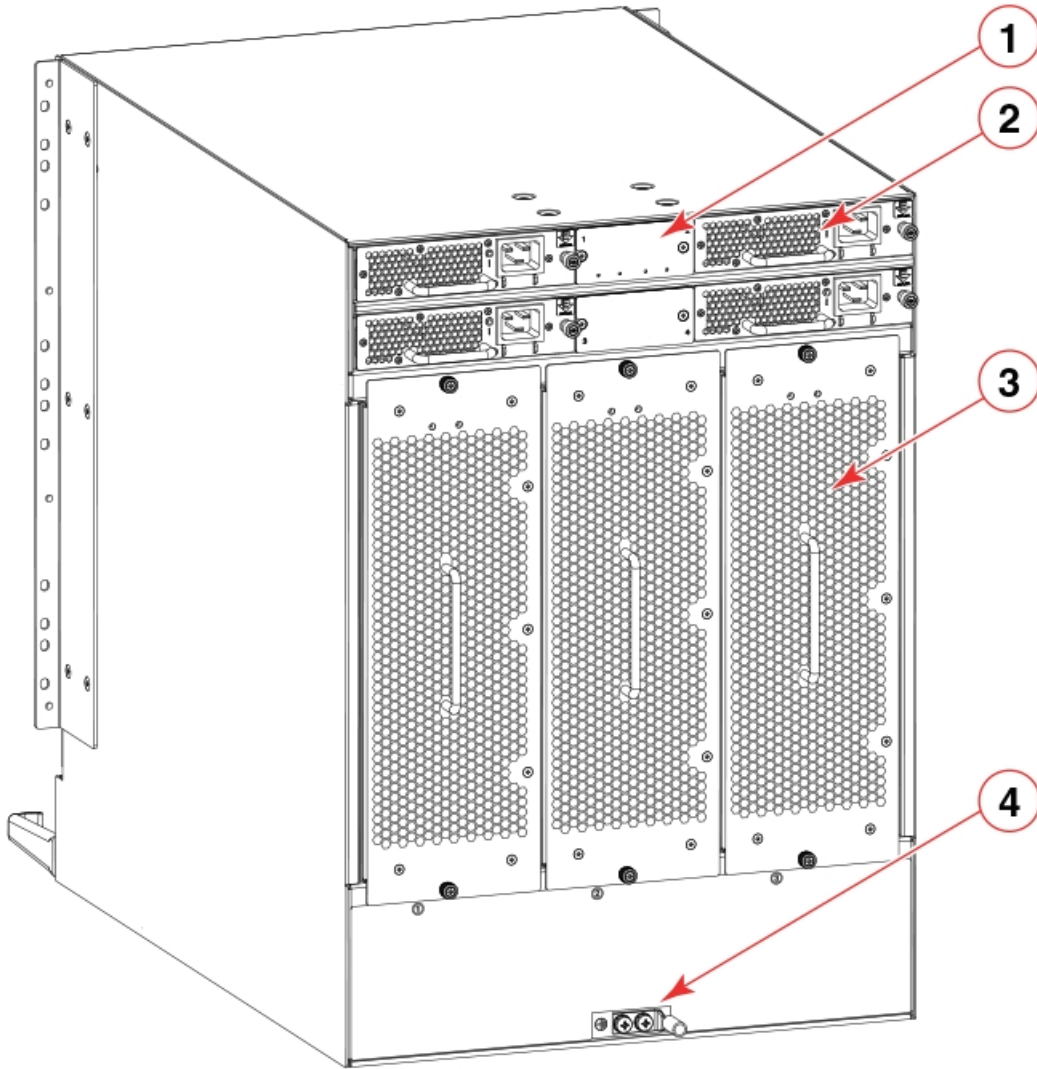

Figure 2. Nonport side of the SAN512B-6 (sample configuration)

- 1 - WWN bezel (WWN cards behind)
- 2 - Power supply assembly
- 3 - Fan assembly
- 4 - 2AWG Panduit LCD2-14AF lug for building ground connection

Depending on fans and power supplies installed, airflow can be from the port side to the nonport side of the chassis or the nonport side to the port side of chassis.

Although not illustrated, the chassis label containing the serial number, SKU, and WWN is located on the lower portion of the chassis, below the fan assemblies.

Chapter 2. Preparing for the Installation

This chapter provides the following information:

- “Safety precautions”
- “Facility requirements” on page 10
- “Time and items required for installation” on page 11
- “Quick installation checklists” on page 13
- “Items shipped” on page 15

Safety precautions

When using this product, observe all danger, caution, and attention notices in this manual. The safety notices are accompanied by symbols that represent the severity of the safety condition.

Refer to the Cautions and Danger Notices at the end of this guide for translations of safety notices for this product.

General precautions



DANGER

The procedures in this manual are for qualified service personnel.



DANGER

Before beginning the installation, see the precautions in “Power precautions.”



CAUTION:

Changes or modifications made to this device that are not expressly approved by the party responsible for compliance could void the user's authority to operate the equipment.



CAUTION:

Disassembling any part of the power supply and fan assembly voids the warranty and regulatory certifications. There are no user-serviceable parts inside the power supply and fan assembly.



CAUTION:

Make sure the airflow around the front, sides, and back of the device is not restricted.



CAUTION:

To protect the serial port from damage, keep the cover on the port when not in use.



CAUTION:
Never leave tools inside the chassis.



CAUTION:
Use the screws specified in the procedure. Using longer screws can damage the device.

ESD precautions



DANGER

For safety reasons, the ESD wrist strap should contain a series 1 megaohm resistor.

Power precautions



DANGER

For safety reasons, the ESD wrist strap should contain a series 1 megaohm resistor.



DANGER

If the installation requires a different power cord than the one supplied with the device, make sure you use a power cord displaying the mark of the safety agency that defines the regulations for power cords in your country. The mark is your assurance that the power cord can be used safely with the device.



DANGER

Make sure that the power source circuits are properly grounded, then use the power cord supplied with the device to connect it to the power source.



CAUTION:

Use a separate branch circuit for each power cord, which provides redundancy in case one of the circuits fails.



DANGER

High Touch Current. Earth connection essential before connecting supply.

Lifting precautions



CAUTION:
Use safe lifting practices when moving the product.



CAUTION:
A fully populated chassis weighs approximately 145.83 kg (321.5 lbs) and requires a hydraulic or assisted lift to install it.



Note: Do not attempt to lift the device by the protective cover attached to the air vents on the nonport-side of the chassis.

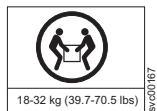

DANGER

If a lift tool with a capacity of at least 350 lb is not available, the director chassis must be depopulated completely before installing it into the rack. Remove the power supplies, fan modules, all of the blades, the cable management comb, and the chassis door (if equipped). Install the empty chassis into the rack following the chassis installation instructions. The weight of the empty chassis is 78.5 lb (35.6 kg) and must be lifted by minimum 3 people. After securing the chassis to the rack, reinstall the power supplies, fan modules, and the blades and proceed with the installation.

Laser precautions



DANGER

All fiber-optic interfaces use Class 1 lasers.



DANGER

Laser Radiation. Do Not View Directly with Optical Instruments. Class 1M Laser Products.



DANGER

Use only optical transceivers that are qualified by Brocade Communications Systems, Inc. and comply with the FDA Class 1 radiation performance requirements defined in 21 CFR Subchapter I, and with IEC 825 and EN60825. Optical products that do not comply with these standards might emit light that is hazardous to the eyes.

Facility requirements

Before installing the device, be sure the following facilities requirements are met.

Table 2. Facility requirements

Type	Requirements
Device specifications	Ensure that the facility can accommodate system, power, and environmental specifications for this device as outlined in the "Product specifications," on page 195.
Electrical	<p>Ensure that there are dedicated electrical branch circuits with the following characteristics are available:</p> <ul style="list-style-type: none">• 200–240 VAC, 50–60 Hz, four branch circuits are recommended for high availability and maximum blade usage.• 110–120 VAC, 50–60 Hz, four branch circuits are highly recommended.• Four cables for 110–120 VAC or 200–240 VAC service.• Protected by a circuit breaker in accordance with local electrical codes.• Supply circuit, line fusing, and wire size adequate to the electrical rating on the chassis nameplate.• Location close to the chassis and easily accessible.• Grounded outlets installed by a licensed electrician and compatible with the power cords. <p>Ensure that all equipment in rack is grounded through a reliable branch circuit connection.</p> <p>Make sure that power distribution units (PDUs) can handle maximum input amperage of power supplies. Use cables with adequate amperage rating from PDUs to power source.</p>
Thermal	<p>Ensure that the air intake and exhaust vents have a minimum of 5.1 cm (2 in.) of airspace.</p> <p>Ensure that the air intake temperature is less than 40°C (104°F) during operation.</p>

Table 2. Facility requirements (continued)

Type	Requirements
Rack (when rack-mounted)	<p>Ensure that these airflow requirements are met:</p> <ul style="list-style-type: none"> • Plan to install the device with the air-intake side facing the cool air aisle. The device can be installed facing either direction if serviceability and cooling requirements are met. • Ensure that the airflow available at the air vents meets the minimum requirements for the device. • Install the device with the airflow aligned with other devices in the rack. Some devices have airflow running from port side to nonport side and others have the opposite arrangement. Make sure that the airflow for all devices moves in the same direction to maximize cooling. <p>Ensure that the following amount of space is available in the rack:</p> <ul style="list-style-type: none"> • 14 rack units (14U) high. 1U is equal to 4.45 cm (1.75 inches). • 61.29 cm (24.09 inch) deep. • 43.74 cm (17.22 inch) wide. <p>Ensure that the rack meets these additional requirements:</p> <ul style="list-style-type: none"> • Additional weight of chassis will not exceed the rack's weight limits. • The rack is secured to ensure stability in case of unexpected movement.

Time and items required for installation

You can set up and install the device in the following ways:

- As a standalone unit on a flat surface.
- In a 19-inch Electronic Industries Association (EIA) rack or in a telecommunications (Telco) rack using a rack mount kit. Refer to “Mounting options” on page 17 for applicable rack mount kits.

The following table describes the main installation and setup tasks, the estimated time required for each, and the items required to complete the task for a device that is fully populated with port blades. Configurations with fewer blades or ports require less time. These time estimates assume a prepared installation site and appropriate power and network connectivity.

Table 3. Installation tasks, time, and items required

Installation task	Time estimate	Items required
Site preparation and unpacking the device.	30 minutes	<p>1/2-in. socket wrench (optional).</p> <p>#1 and #2 Phillips screwdrivers.</p> <p>Pallet jack.</p> <p>Hydraulic or assisted lift with a minimum raise of 140 cm (55 in.) and a minimum capacity of 158.76 kg (350 lb)</p> <p>To find the weight of your device fully populated with the required port blades, refer to "Product specifications," on page 195.</p>
Installing rack mount kit .	30 minutes	Refer the procedures for your rack mount kit located in this guide.
Mounting and securing the device in rack.	30 minutes	
Installing power cables and powering on the device.	20 minutes	Power cables. These are ordered and shipped separately based on country where device is installed.
Establishing serial connection, logging in to the device, and configuring IP addresses.	20 minutes	<p>Serial cable (provided in the accessory kit).</p> <p>Workstation computer with a serial port or terminal server port and a terminal emulator application (such as HyperTerminal).</p> <p>Ethernet IP addresses for the device and for both control processor blades; total of three addresses.</p>
Installing an Ethernet cable, opening a Telnet session, and configuring the device domain ID, date and time, and additional system parameters. Verify and back up configuration.	20 minutes	<p>Ethernet cabling (optional) for Telnet access.</p> <p>Refer to the <i>Fabric OS Administrator's Guide</i>.</p>
Installing transceivers as needed.	20-30 minutes or longer if you are using high-density port blades.	SFP+ and QSFP28 optical transceivers as needed.
Attaching fiber-optic cables, cable ties, and cable guides.	2-3 hours	Fiber-optic cables, cable ties, and cable management comb.

Quick installation checklists

These checklists provides a high-level overview of the basic installation process from the planning stage to the point where the device comes online and is ready to be deployed. Completing all the tasks in the suggested order ensures successful installation. It is recommended that you print these checklists and take them to the installation site.

Pre-installation tasks

Review all installation requirements ahead of time as part of your site preparation. Careful planning and site preparation ensures seamless installation, especially when installing multiple devices.

Table 4. Installation prerequisites

Task	Task details or additional information	Completed
Unpack the device.	Take an inventory of the hardware components included in your shipment. Refer to “Items shipped” on page 15.	
Gather necessary components and required tools.	Review the time and items required information at the beginning of the following sections in this guide to ensure you have gathered all necessary components required: <ul style="list-style-type: none">• <i>Mounting the Device</i>• <i>Initial Setup and Verification</i>• <i>Port and Extension Blades</i> (if required to install)• <i>Power Supplies</i> (if required to install)	
Review the safety precautions.	Refer to “Safety precautions” on page 7.	
Plan the installation.	Obtain the appropriate rack mount kit. Refer to “Mounting options” on page 17.	
Review and verify installation requirements.	Verify that the following requirements are met. Refer to “Facility requirements” on page 10. <ul style="list-style-type: none">• Electrical• Environmental• Rack• Thermal	
Gather network configuration parameters.	<ul style="list-style-type: none">• IP address• Subnet mask• Default gateway• Domain ID• Time zone	

Installation and initial configuration

The initial setup includes mounting the device on a flat surface or in a rack and completing the configuration tasks necessary to bring the device online and verify the operation.

Table 5. Installation and basic system configuration

Task	Task details or additional information	Completed
Install blades or power supply assemblies	Install any blades or power supply assemblies that have shipped separately from the chassis. Be sure to use a #1 Phillips screwdriver for captive screws to lock these FRUs into place.	

Table 5. Installation and basic system configuration (continued)

Task	Task details or additional information	Completed
Mount the device	<p>Choose one of the following mounting options:</p> <ul style="list-style-type: none"> • Mount the device in a four-post rack. Refer to the instructions in this guide for mounting your device in a four-post rack. • Mount the device in a two-post rack. Refer to the instructions in this guide for mounting your device in a two-post rack. 	
Check the airflow of the power supply and fan assembly	The airflow direction of the power supply and fan should match. The power supplies and fan trays are clearly labeled with either a green arrow with an "E", or an orange arrow with an "I." For more details, refer to "Fan and power supply airflow" on page 152.	
Gather all components required for the initial setup	Refer to "Items required" on page 36.	
Provide power to the device	Refer to "Providing power to the device" on page 37.	
Attach a management station, establish a serial connection, and change the default passwords (optional)	Refer to "Establishing a serial connection to the device" on page 38. After completing this task, log in to the serial port to configure the device.	
Set the IP address, subnet mask, and the default gateway IP address	Use the ipaddrset command to configure a static device IP address, subnet mask, and gateway IP address, or you can use a DHCP server to obtain the information dynamically. Refer to "Configuring the IP addresses" on page 39.	
Set the date and time	<ul style="list-style-type: none"> • Use the date command to display and set the date and time. • Use the tstimezone command to display and set the time zone. • Use the tsclockserver command to synchronize the time with an external NTP server. <p>Refer to "Setting the date and time" on page 42 for more information.</p>	
Customize the switch name and chassis name	<ul style="list-style-type: none"> • Use the switchname command to change the default switch name. • Use the chassisname command to change the default chassis name. <p>Refer to "Customizing the chassis and switch name" on page 44 for more information.</p>	
Establish an Ethernet connection	By establishing an Ethernet connection, you can complete the device configuration using a serial session, Telnet, or management application, such as IBM Network Advisor. Refer to "Establishing an Ethernet connection to the device" on page 41.	
Optional: Configure the DNS service	Use the dnsconfig command to create DNS server entries. Refer to the <i>Fabric OS Administrator's Guide</i> .	
Optional: Customize the domain ID	Use the configure command to change the domain ID (default ID is 1). Refer to "Setting the domain ID" on page 41 for more information.	

Table 5. Installation and basic system configuration (continued)

Task	Task details or additional information	Completed
Verify that the device operates correctly	<ul style="list-style-type: none"> • Check the LEDs to verify operation of functional parts. Refer to the <i>Monitoring the Device</i> section of this guide. • The following commands can be useful to establish an operational baseline for the device. Refer to the <i>Fabric OS Command Reference</i> for more information on these commands. <ul style="list-style-type: none"> – psshow – fanshow – tempshow – historyshow – errdump 	
Back up the configuration	Use the interactive configupload command to back up the configuration. Refer to “Backing up the configuration” on page 47 for more information.	
Optional: Power off the devices	Enter the shutdown command and wait for the device to power down, and then unplug the power cords. Refer to “Powering down the chassis” on page 48 for more information.	

Items shipped

When unpacking the device, follow procedures under "Unpacking and transporting the device". Verify that you have the following items. Save shipping cartons and packaging in the event you need to return the device.

Packaged in device shipping carton:

- SAN512B-6 switch with shipping tray
- Packing foam
- Antistatic plastic
- Inner foam

Packaged in device shipping carton or separate carton.

- Door (for EMI compliancy)
- Power cords as ordered for installed power supplies
- Serial cable
- ESD wrist strap
- SFP extraction tool
- Power cord retainer clips
- Cable management comb assembly
- China-RoHS Hazardous/Toxic Substance statement
- Network Advisor web pointer card
- IBM documentation web pointer card
- Rack mount kit for your device
- Ground lug kit

Chapter 3. Mounting the Device

This chapter provides the following information:

- “Mounting options”
- “Mounting precautions”
- “Unpacking and transporting the device” on page 19
- “Port-side slot numbering” on page 5
- “Installing the 14U Rack Mount Kit for Four-Post Racks” on page 20
- “Installing the 14U Chassis Mid-Mount Rack Kit for Two-Post Racks” on page 27
- “Removing the protective cover” on page 33

Mounting options

You can mount the device in the following locations:

- In a four-post 19 in. (48.3 cm) EIA rack:
 - Use the 14U rack mount kit for four-post racks (XBR-DCX-0120), which contains shelf brackets that telescope from 27 in. (68.58 cm) to 31 in. (78.74 cm) to fit the majority of racks.
 - Use the 14U rack mount kit for four-post racks (XBR-DCX-0152), which contains 22 in. (55.88 cm) fixed shelf brackets designed for specific racks.
 - Refer to “Installing the 14U Rack Mount Kit for Four-Post Racks” on page 20 for instructions.
- In a two-post Telco rack:
 - Use the 14U mid-mount rack kit for two-post racks (XBR-DCX-0121).
 - Refer to “Installing the 14U Chassis Mid-Mount Rack Kit for Two-Post Racks” on page 27 for instructions .

Note: Review the “Mounting precautions” before mounting the device and ensure that all “Facility requirements” on page 10 are met.

Mounting precautions

The following precautions specifically apply to mounting the device.



CAUTION:

Do not use the port cover tabs to lift the module. They are not designed to support the weight of the module, which can fall and be damaged.



DANGER

Make sure the airflow around the front, sides, and back of the device is not restricted.



DANGER

Mount the devices you install in a rack as low as possible. Place the heaviest device at the bottom and progressively place lighter devices above.



DANGER

Use safe lifting practices when moving the product.



CAUTION:

To prevent damage to the chassis and components, never attempt to lift the chassis using the fan or power supply handles. These handles were not designed to support the weight of the chassis.



CAUTION:

Do not attempt to lift the chassis by the protective cover attached over the air vents on the port side.



CAUTION:

You can connect the device to building ground by connecting an appropriate 2 AWG wire from a grounded connection to the 2AWG Panduit LCD2-14AF lug on the nonport-side of the device.

Unpacking and transporting the device

About this task

Use the following procedure to unpack and install your device.

DANGER

A fully populated chassis weighs approximately 145.83 kg (321.5 lbs) and requires a hydraulic or assisted lift to install it.

If a lift tool with a capacity of at least 350 lb is not available, the director chassis must be depopulated completely before installing it into the rack. Note any possible interconnecting cables so that you will be able to reconnect them correctly. Remove the power supplies, fan modules, all of the blades, the cable management comb, and the chassis door (if equipped). Install the empty chassis into the rack following the chassis installation instructions. The weight of the empty chassis is 78.5 lb (35.6 kg) and must be lifted by minimum 3 people. After securing the chassis to the rack, reinstall the power supplies, fan modules, the blades and any possible interconnecting cables and proceed with the installation.

Procedure

1. Unpack the device.
 - a. Cut the bands that encircle the packaging.
 - b. Open the top of the shipping box and remove accessory kit, rack mount kits, and foam from the top of the device.
 - c. Lift the cardboard shipping container and inner cardboard sleeve off the device.
 - d. Remove the antistatic plastic off the device.
 - e. Leave the device on top the foam shipping tray and wood pallet if the device must be transported to the installation location.
 - f. Verify the contents of the shipping carton by referring to “Items shipped” on page 15.
 - g. Save foam packing material and wooden pallet for reuse.
2. Use a pallet jack or other assisted lift to transport the device to the installation area. Doorways must be wider than 36 in. (91 cm) to accommodate the device.
3. Remove the chassis door if installed.
4. Remove the cable management comb if attached to the device.
5. Use a lift to raise the device to the correct level. Use two people, one to operate the lift and the other to secure the device on the lift.

Note: Do not attempt to lift the device by the protective cover attached to over the air vents on the port side of the chassis.

Note: Orient the device on the lift so that you can slide it into correct side of rack to provide cool air intake. Fans and power supply FRUs in this device have a green "E" or "I" symbol on the FRU faceplate. An "E" indicates that the FRU pulls air from the port side of the device and exhausts out the nonport side. An "I" indicates that the FRU pulls air from the nonport side of the device and exhausts out the nonport side. Fans and power supplies must have

the same airflow indicator. Be sure that you are pulling cool air into the air intake side of the device. For more details, refer to “Fan and power supply airflow” on page 152.

6. If applicable, lock the wheels of the lift.
7. Install the applicable rack mount kit in your equipment rack and mount the device using the rack mount kit's installation instructions.

Note: When installing the device into the rack, use one person on each side of the device to gently slide it onto the final installation surface and ensure that it remains supported during the transfer.

8. Reinstall the cable management comb if you removed it.
9. Install the vertical cable management fingers on the rack's upright posts.
10. Reinstall the chassis door. The door must be installed to meet EMI compliance.

Port-side slot numbering

The SAN512B-6 contains 10 full-height slots and two half-height slots, for a total of 12 slots. Facing the port side of the device, the half-height slots are on the left, numbered 1 (top slot) and 2 (bottom slot). The remaining full-height slots are numbered 3 through 12, counting from left to right of chassis.

Slots contain guide pins and connectors designed for specific blade types. Only install the control processor (CP), core routing (CR), port, and extension blades into slot numbers as follows:

- Slots 1– 2 are restricted to CP blades. Note that the blade installed in slot 1 will be designated as CP0, while the blade in slot 2 will be designated as CP1 in CLI command and message output.
- Slots 3–6 and slots 9–12 are restricted to port and extension blades.
- Slots 7– 8 are restricted to CR32-8 blades.

Installing the 14U Rack Mount Kit for Four-Post Racks

Use the following instructions to install a modular device in a 19-in. (48.3 cm) EIA rack using the 14U Rack Mount Kit for Four-Post Racks. Any updates to these instructions will be added to the hardware installation guide for your product.

Two rack-mount kits are available.

1. Contains shelf brackets that telescope from 27 in. (68.58 cm) to 31 in. (78.74 cm) to fit the majority of racks.
2. Contains 22 in. (55.88 cm) fixed shelf brackets that are designed for specific racks.

Note: Hardware devices illustrated in these procedures are only for reference and may not depict the device you are installing into the rack.

Time and items required

Allow approximately one hour to unpack and install a device in a rack.

The following tools are required when installing the 14U Rack Mount Kit for Four-Post Rack:

- Torque screwdriver with #2 Phillips screwdriver tip

- Slotted (flat blade) screwdriver
- Hydraulic or assisted lift with a minimum raise of 140 cm (55 in.) and a minimum capacity of 158.76 kg (350 lbs)

DANGER

If a lift tool with a capacity of at least 350 lbs is not available, the director chassis must be depopulated completely before installing it into the rack. Note any possible interconnecting cables so that you will be able to reconnect them correctly. Remove the power supplies, fan modules, all of the blades, the cable management comb, and the chassis door (if equipped). Install the empty chassis into the rack following the chassis installation instructions. The weight of the empty chassis is 78.5 lbs (35.6 kg) and must be lifted by minimum 3 people. After securing the chassis to the rack, reinstall the power supplies, fan modules, the blades and any possible interconnecting cables and proceed with the installation.

Parts list

The following table lists the parts supplied in the 14U Chassis Rack Mount Kit. for Four-Post Racks.

Note:

Depending on the device and installation, not all parts may be used on the device type.

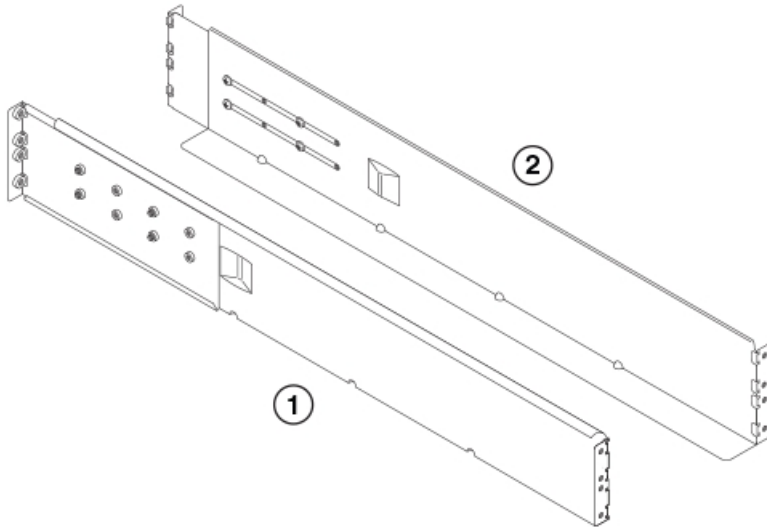

- 1 - Left rack mount shelf bracket
- 2 - Right rack mount shelf bracket
- 3 - 10-32 x 5/8 in. (1.58 cm) panhead Phillips screw and washer
- 4 - 10-32 clip nut for racks that have rails with round holes
- 5 - 1/4-20 x 1/2 in. (1.27 cm) panhead Phillips screw with lock washer for racks that have rails with round holes
- 6 - 10-32 retainer nut for racks that have rails with square holes
- 7 - 1/4-20 x 1/2 in. (1.27 cm) panhead Phillips screw with thread locker for racks that have rails with square holes
- 8 - 3/8 in. (0.953 cm) alignment washer for racks that have rails with square holes

Figure 3. Rack kit parts

Assembling the rack hardware

About this task

Attach the left and right rack mount shelf brackets to the rack rails.

Note: If cables are to be routed down through the cable management comb, allow space below the brackets for cable management

Procedure

1. Locate the shelf brackets in the device.
2. Locate and loosen the screws on the adjustable ends of the brackets (see the following figure) to allow for adjustment to rack depth.

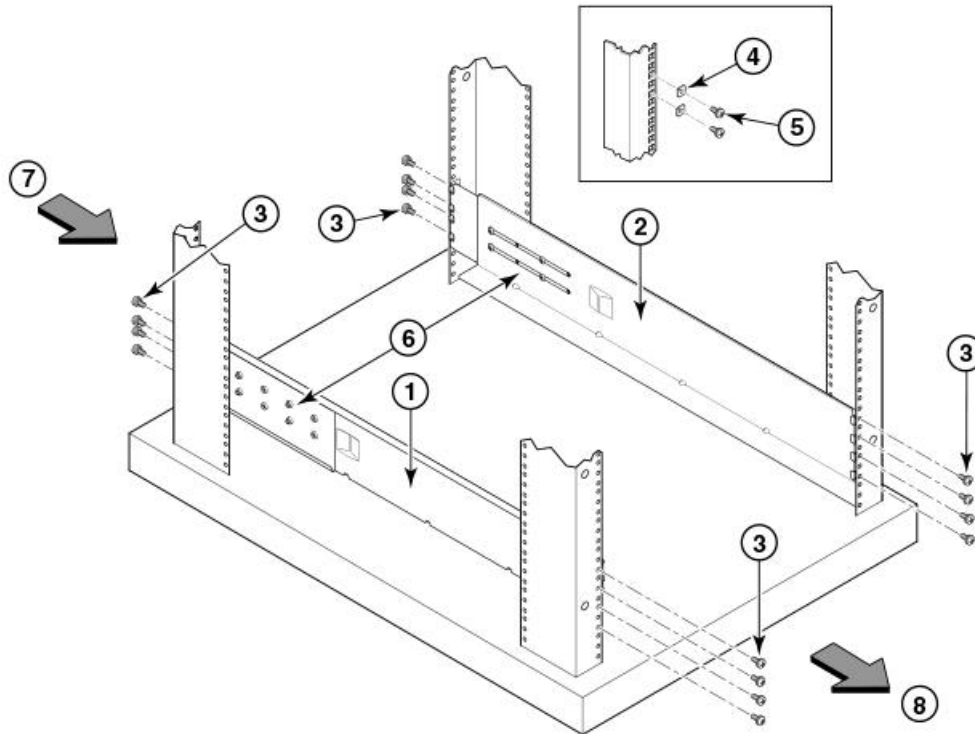

Figure 4. Left and right shelf brackets installed on rails

- 1 - Left rack mount shelf bracket
- 2 - Right rack mount shelf bracket
- 3 - 1/4-20 x 1/2 in. (1.27 cm) panhead Phillips screw with lock washer for rails with round holes (4 on each end of each bracket, 16 total)
- 4 - 3/8 in. (0.953 cm) alignment washer for rails with square holes (4 on each end of each bracket, 16 total)
- 5 - 1/4-20 x 1/2 in. (1.27 cm) panhead Phillips screw with thread locker for rails with square holes (4 on each end of each bracket, 16 total)
- 6 - Adjustable ends of shelf brackets
- 7 - Intake air direction
- 8 - Exhaust air direction



CAUTION:

Use the screws specified in the procedure. Using longer screws can damage the device.

3. Position the shelf brackets with the adjustable ends on the intake air aisle side of the rack (see the previous figure).
 - For rails with round holes:
 - Position the left and right rack mount shelf brackets and attach them to the rack rails. Use eight screws with lock washers per bracket (four on each end). Tighten the screws to a torque of 80 in-lb (92 cm-kg).

- For rails with square holes:
 - Position the left and right rack mount shelf brackets and attach them to the rack rails. Use eight screws and alignment washers per bracket (four on each end). Tighten the screws to a torque of 80 in-lb (92 cm-kg).

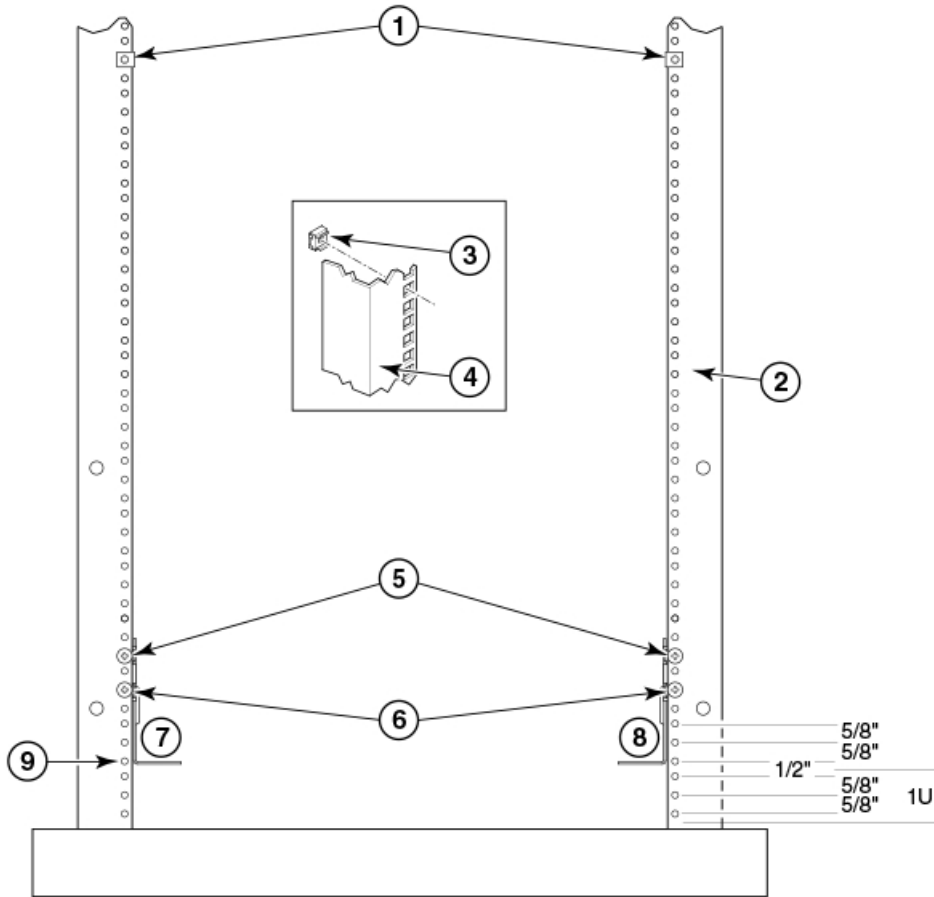

Figure 5. Nut and screw locations for mounting the device

- 1 - 10-32 clip nuts (for round holes)
- 2 - Rail
- 3 - 10-32 retainer nut (for square holes)
- 4 - Rail
- 5 - Top screws in shelf bracket
- 6 - Bottom screws in shelf bracket
- 7 - Left rack mount shelf bracket
- 8 - Right rack mount shelf bracket
- 9 - Hole 1

Note: Standard EIA rails have holes in sets of three; spaces between the holes are 5/8 in., 5/8 in., and 1/2 in. (1.58 cm, 1.58 cm, and 1.27 cm).

4. Tighten the adjusting screws on the sliding portion of the rack mount shelf brackets to a torque of 32 in-lb (37 cm-kg).
5. Attach the clip nuts (for rails with round holes) or retainer nuts (for rails with square holes) to the vertical rails on the exhaust aisle side of the rack (see the

previous figure). These clip nuts are used for securing the port side of the device to the rack rails using 10-32 x 5/8 inch screws. Use three clips on each rail. Place the clips in optimum locations for securing the device to the rails.

Note: Do not align the clip or retainer nuts with the top or bottom holes of the mounting bracket because the screw heads will interfere with the door.

Installing the device in the rack

About this task

Use the following procedure to install the device in the rack.



DANGER

Use safe lifting practices when moving the product.

Procedure

1. Ensure that the door, if installed, is removed from the port side of the device. For instructions, refer to instructions for removing and replacing the device door in the device installation guide.
2. Use a lift to raise the device to the level of the shelf brackets.
3. Move the lift as close as possible to the rack, with the air-intake side of the device facing the front of the rack (see the following figure).
4. If applicable, lock the wheels of the lift.
5. Gently slide the device onto the shelf brackets, ensuring that it remains supported during the transfer.
6. Fasten the port side of the device to the rack rails. Use three 10-32 x 5/8 inch (1.58 cm) screws per rail. Tighten the screws to a torque of 32 in-lb (37 cm-kg). Refer to Figure 5.

Note: Do not use the top or bottom holes of the mounting bracket because the screw heads will interfere with the door.

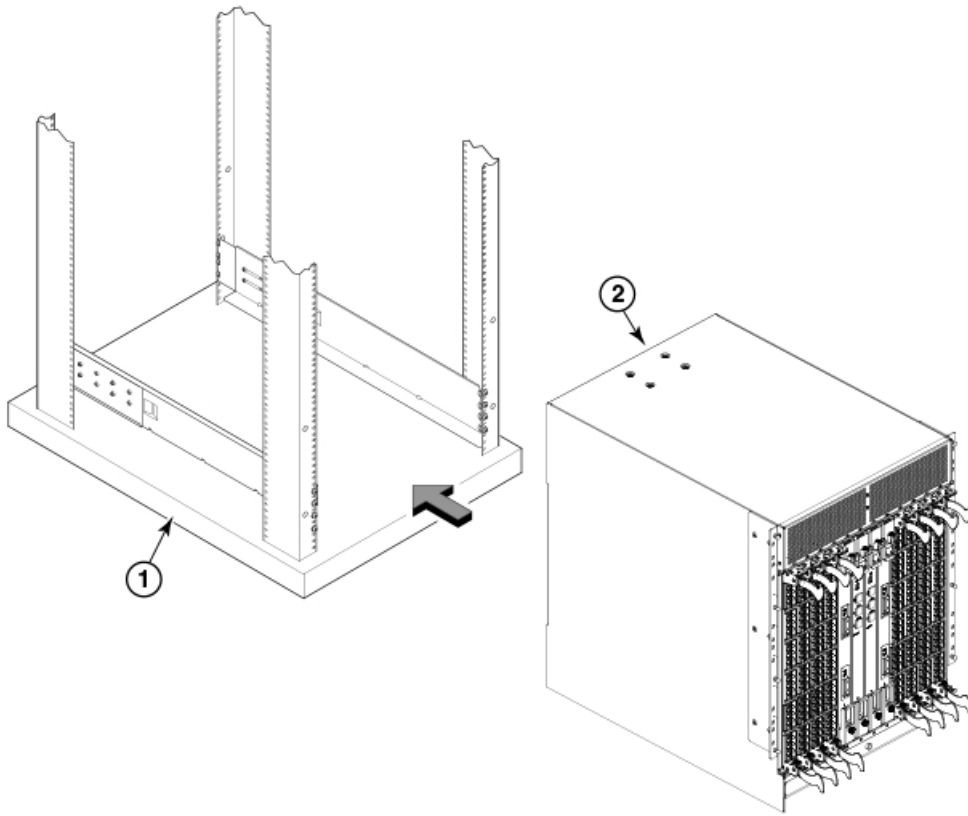

Figure 6. Positioning the device for installation in a rack

- 1 - Rack
- 2 - Nonport side of device

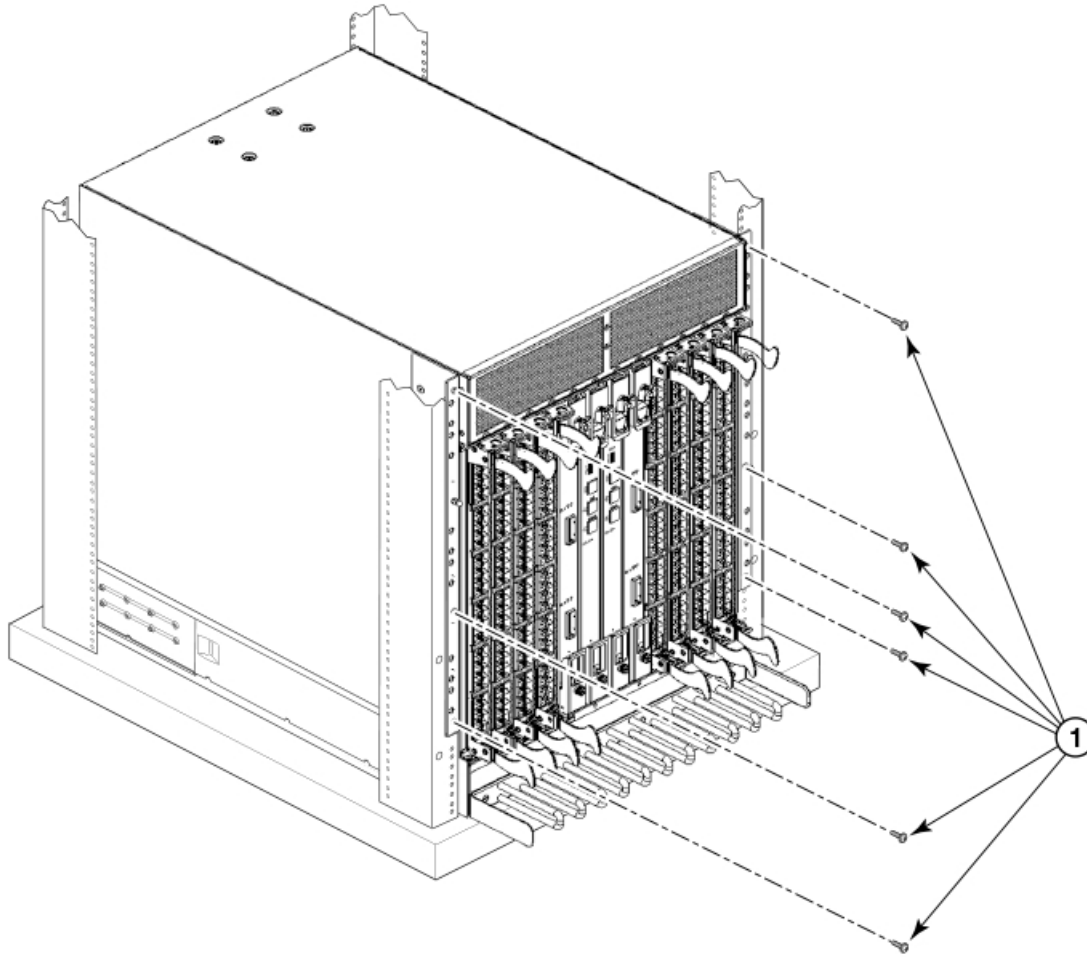

Figure 7. Attaching port side of device to rack rails

1 - 10-32 x 5/8 in. (1.58 cm) panhead Phillips screw with washer

7. Reinstall the device door if removed from your device. For instructions, refer to the door removal and replacement procedures in your device installation guide.

Installing the 14U Chassis Mid-Mount Rack Kit for Two-Post Racks

Use the following instructions to install a modular device in a telecommunications (Telco) rack, using the 14U Chassis Mid-Mount Rack Kit for Two-Post Racks.

The kit is compatible with rack rails that are either 3 inches or 5 inches wide (adapters are provided for 3-in. rails). Any updates to these instructions will be added to the hardware installation guide for your product.

Note: Hardware devices illustrated in these procedures are only for reference and may not depict the device you are installing into the rack.

Time and Items required

Allow approximately one hour to unpack and install a chassis in a rack.

The following tools are required when installing the 14U Chassis Mid-Mount Rack Kit for Two-Post Racks.

- Torque wrench with #2 Phillips screwdriver tip.

- Flathead screwdriver.
- Hydraulic or assisted lift with a minimum raise of 140 cm (55 in.) and a minimum capacity of 158.76 kg (350 lbs)

DANGER

If a lift tool with a capacity of at least 350 lbs is not available, the director chassis must be depopulated completely before installing it into the rack. Remove the power supplies, fan modules, all of the blades, the cable management comb, and the chassis door (if equipped). Install the empty chassis into the rack following the chassis installation instructions. The weight of the empty chassis is 78.5 lbs (35.6 kg) and must be lifted by minimum 3 people. After securing the chassis to the rack, reinstall the power supplies, fan modules, and the blades and proceed with the installation.

Parts list

The following parts are provided with the 14U Chassis Mid-Mount Rack Kit for Two-Post Racks.

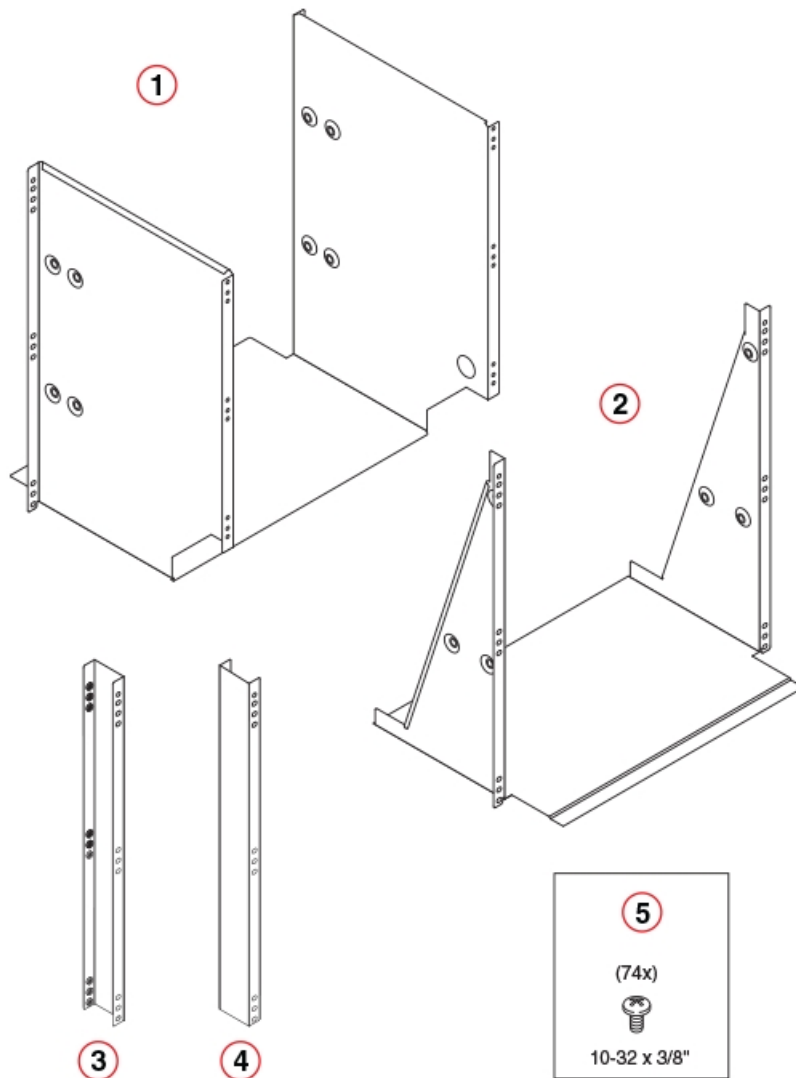

Figure 8. Rack kit parts

- 1 - Tray, front, mid-mount, chassis
- 2 - Tray, rear, mid-mount, chassis
- 3 - Adapter, rear, mid-mount, right
- 4 - Adapter, rear, mid-mount, left
- 5 - Screw, 10-32 x 3/8", pan head Phillips, ST, zinc (requires a torque of 32 inch-pounds)

Note: Not all parts may be used with certain installations depending on the device type.

Assembling the rack hardware

About this task

Perform the following steps to assemble the rack hardware.

Procedure

1. Attach the rear tray (with or without adapter, as required) to both rack rails. Orient the tray (refer the following figure) and use nine screws (Item E) for each rail.
2. Attach the front tray to both rack rails. Orient the tray (Figure 3) and use nine screws (Item E) for each rail.
3. Verify that the rear edge of the front tray is seated into the front edge of the rear tray.

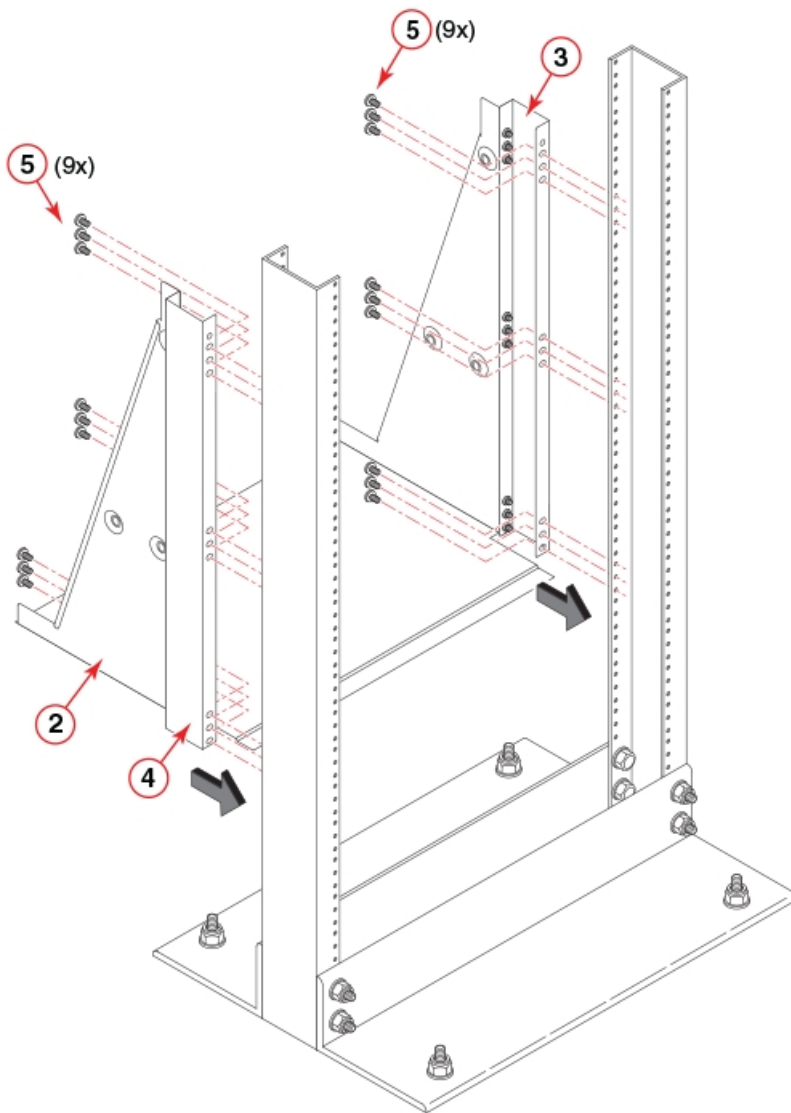

- 1 - Tray, rear, mid-mount, chassis
- 2 - Adapter, rear, mid-mount, right
- 3 - Adapter, rear, mid-mount, left
- 4 - Screws

Figure 9. Attaching the rear tray to the rack rails

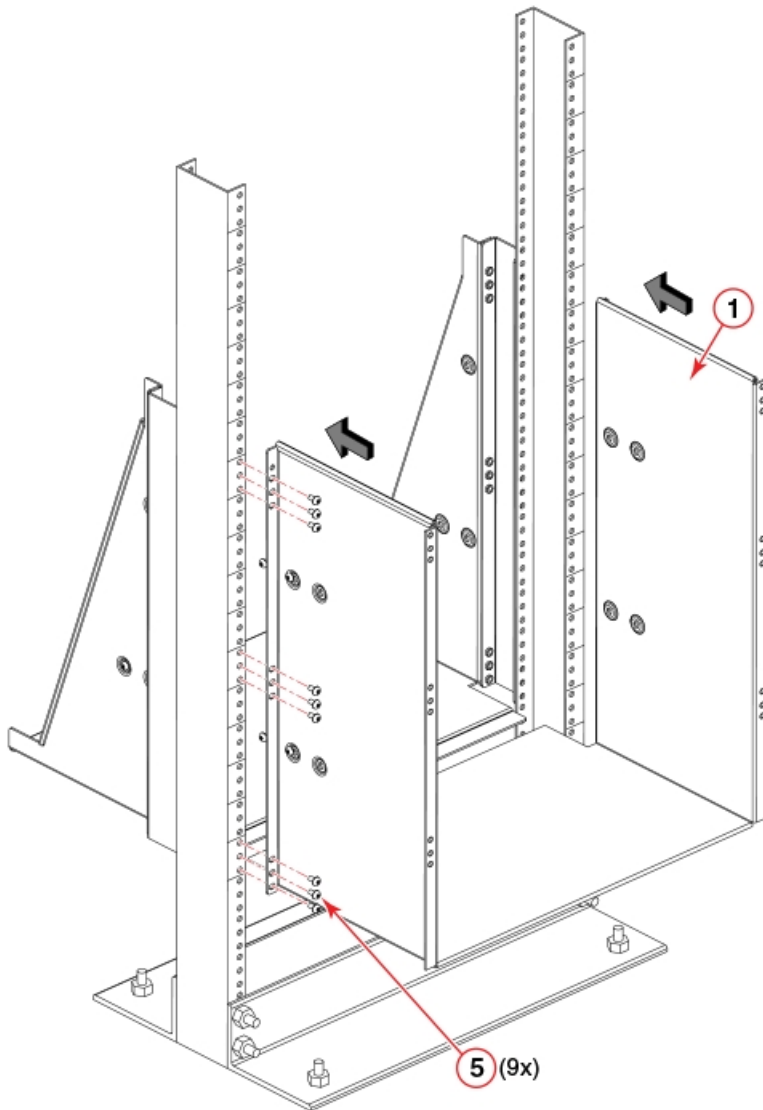

- 1 - Tray, front, mid-mount, chassis
- 2 - Screws

Figure 10. Attaching the front tray to the rack rails

Installing the device in the rack

About this task



DANGER

Use safe lifting practices when moving the product.

Note: A fully populated device requires a hydraulic or assisted lift to install into a rack.

Perform the following steps to load the device into the mid-mount trays.

Procedure

1. Ensure that the door is removed from the port side of the device. For instructions, refer to the door removal and replacement procedures in your device installation guide.
2. Orient the device (refer the following figure) and use a hydraulic lift to raise it to the level of the trays.
3. If applicable, lock the wheels of the lift.
4. Slide the device into the trays until the front edge of the device is seated against the front tray.

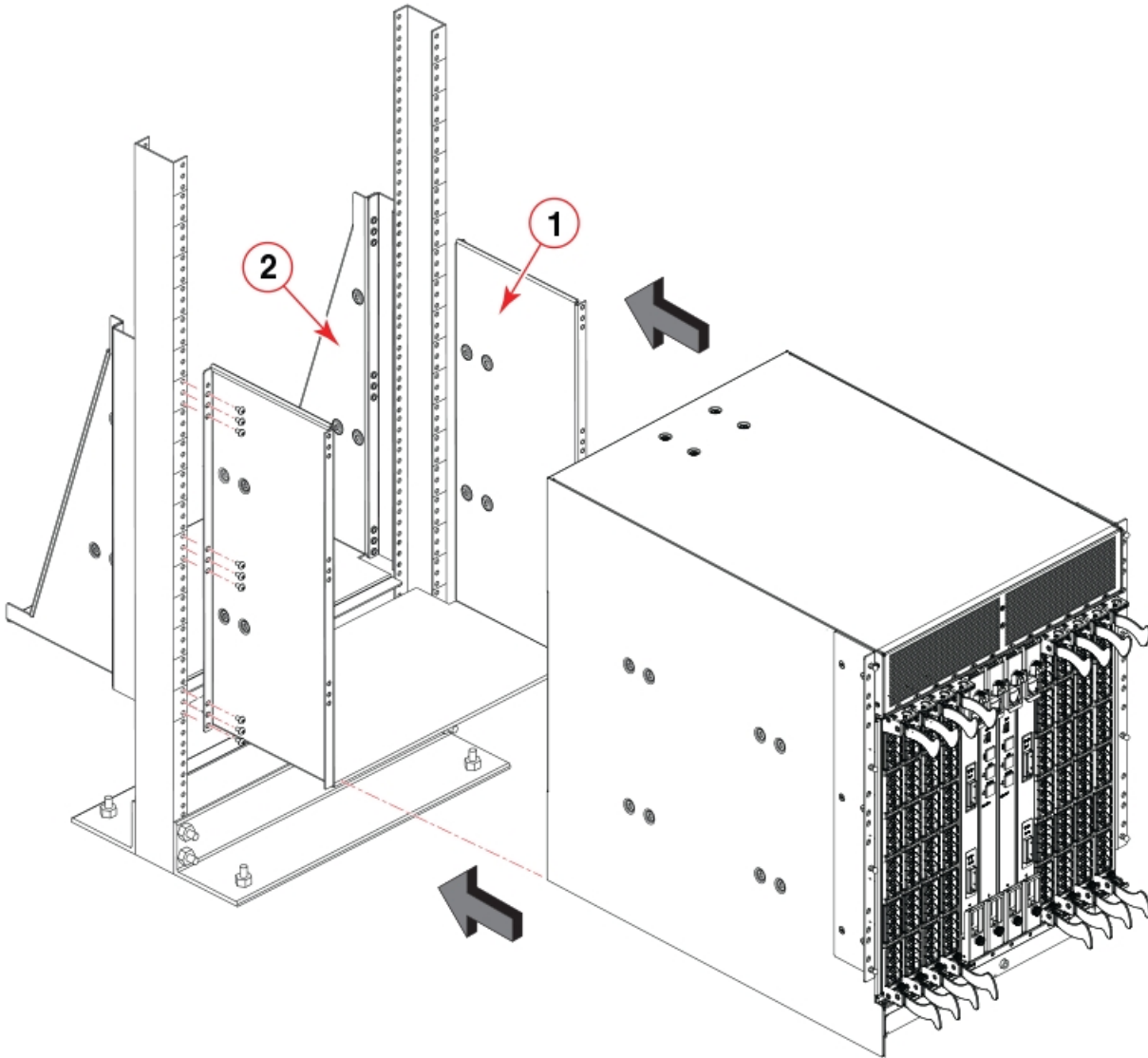

Figure 11. Placing the device in the trays

- 1 - Tray, front, mid-mount, chassis
 - 2 - Tray, rear, mid-mount, chassis
5. Use three screws (Item 5) to attach each side of the rear tray to the device (refer the following figure).

Note: The screw holes in the device walls have pem nuts on the inside surface.

6. Use four screws (Item 5) to attach each side of the front tray to the device
7. Use six screws (Item 5) to attach the lip on each side of the front tray to the lip on the front of the device.

Note: Do not use the top or bottom holes of the mounting bracket because the door will interfere with the screw heads.

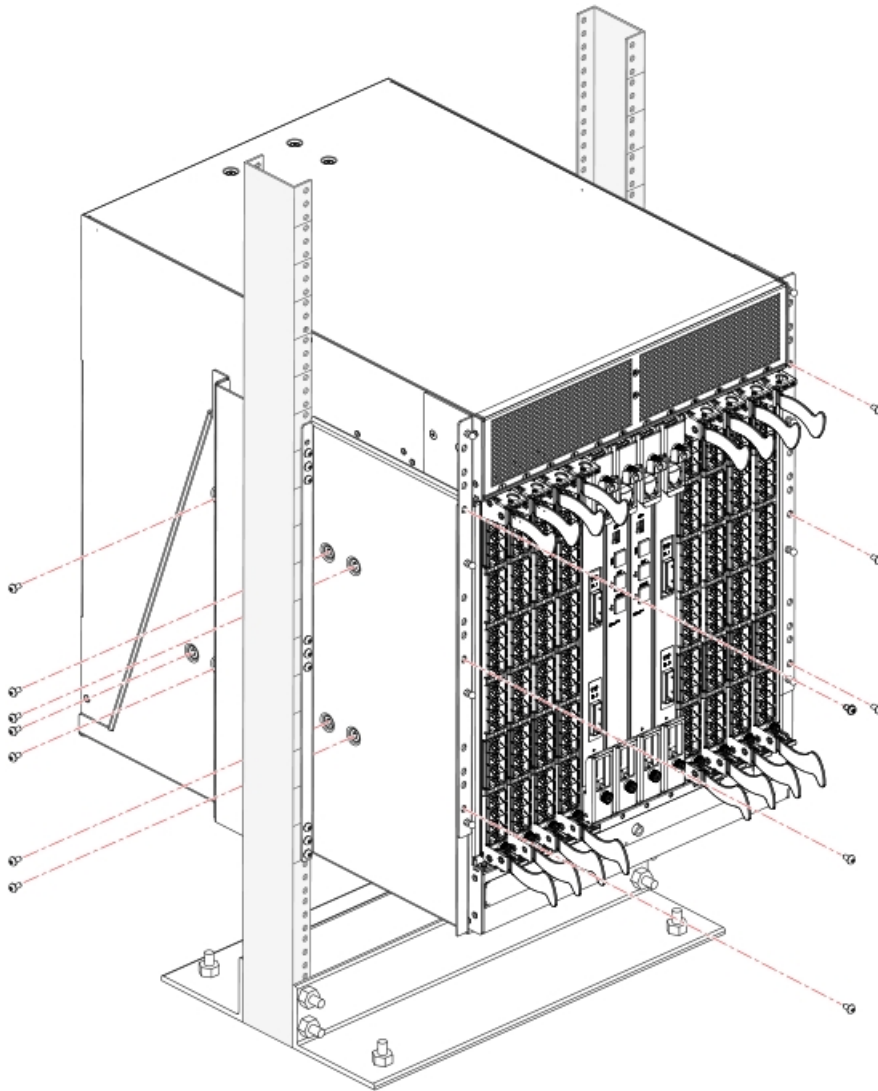

Figure 12. Attaching trays to the device

8. Reinstall the device door. For instructions, refer to the door removal and installation instructions in your device installation guide.

Removing the protective cover

About this task

The chassis ships with a protective cover installed over the air vents at the top of the port side of the chassis.



CAUTION:

You must remove the protective cover on the port side of the chassis before applying power to the chassis. The chassis can overheat if air vents are blocked with this cover.

Remove this cover by removing the Phillips screws securing it to the mounting bracket on each side of the chassis.

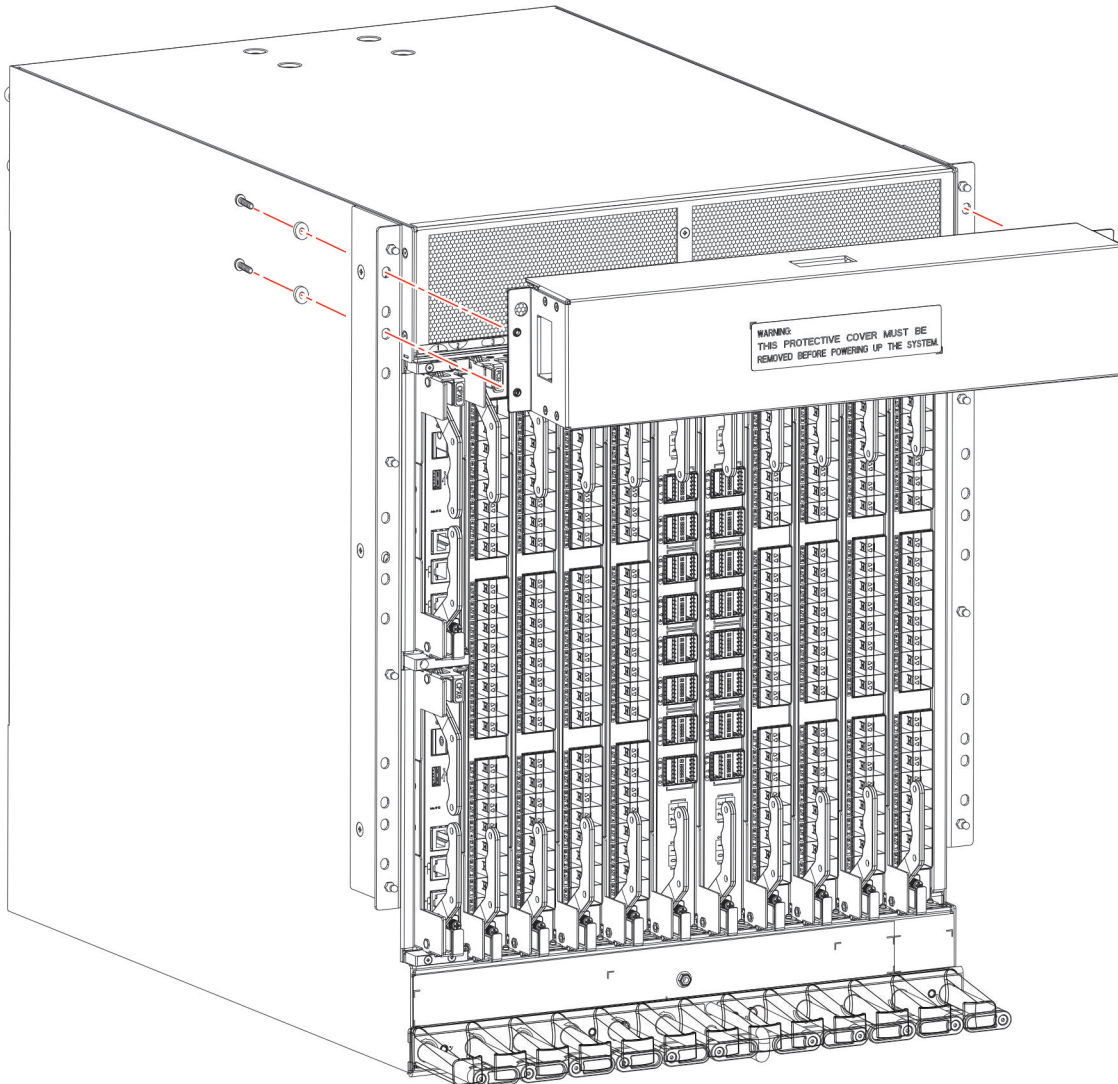

Figure 13. Removing protective cover from SAN512B-6

Note: Do not attempt to lift or support the chassis by the protective cover.

Chapter 4. Initial Setup and Verification

This chapter provides the following information:

- “Configuration and verification task guide”
- “Items required” on page 36
- “Providing power to the device” on page 37
- “Establishing a serial connection to the device” on page 38
- “Configuring the IP addresses” on page 39
- “Establishing an Ethernet connection to the device” on page 41
- “Setting the date and time” on page 42
- “Customizing the chassis and switch name” on page 44
- “Verifying the PID mode” on page 45
- “Verifying installed licenses and license key” on page 46
- “Verifying correct operation” on page 46
- “Backing up the configuration” on page 47
- “Powering down the chassis” on page 48

Configuration and verification task guide

Before connecting the device to the fabric, use the following tasks to initially configure and setup the device, verify correct operation, and back up the configuration.

The configuration information is mirrored to the standby CP blade, which allows the current configuration to remain available even if the active CP blade fails. The configuration information for the device is stored in the WWN cards and the flash memory of the CP blades. The configuration can be backed up to a workstation (uploaded) and then downloaded to the active CP blade if necessary.

Note: The device WWN is set by the factory to match the license ID (which is based on the chassis serial number).

Table 6. Configuration and verification tasks

Task	Task details or additional information
Establish a serial connection to the device (chassis).	Connect a serial cable to the console port on active CP blade and use a terminal emulator program (such as HyperTerminal on a PC, or TERM, TIP, or Kermit in a UNIX environment) to log in to the console port and device. The blue "Active" LED illuminates on the active CP blade.
Configure IP addresses for the device.	Configure an IP address and subnet mask for a chassis management connection. Configure IP addresses, host names, subnet masks, and gateway addresses for both control processor (CP) blades.

Table 6. Configuration and verification tasks (continued)

Task	Task details or additional information
Establishing an Ethernet connection to the device.	Connect Ethernet cable to active CP blade Ethernet port labeled "Management" and establish a connection.
Set a unique domain ID for the device.	Disable the device using the switchDisable command, and then use the configure command to step through prompts to configure a domain ID. Use switchEnable to re-enable the device.
Set the date and time for the device.	Use the date , tsTimeZone , and tsClockServer commands to set date, time zone, and synchronize local time of device with NTP server.
Customize a switch and chassis name for the device.	Use the switchName command, followed by new name in quote marks (switchname "bigswitch".) Use the chassisName command followed by the new name in quote marks (chassisname "chassis_002").
Verify installed licenses and license key	Enter the licenseShow command to determine display enabled licenses and the license key. Enter the licenseIdShow command to obtain the chassis ID. Record the license key and chassis ID for future reference.
Verify correct operation of device.	Check LEDs on blades and FRUs, and use the following commands to verify operation: <ul style="list-style-type: none"> • psShow • fanShow • switchShow • fabricShow • slotShow • tempShow • historyShow • errdump
Back up the configuration.	Use the configUpload command.

Items required

The following items are required for initial setup and verification of the device:

- The device, mounted and installed with the required blades, FRUs, transceivers, and cables and is connected to a power source.
- A workstation computer with an installed terminal emulator application, such as HyperTerminal for Windows.
- An unused IP address with corresponding subnet mask and gateway address.
- A serial cable (provided) with an RJ-45 connector.
- An RJ-45 to DB-9 adapter.

- Three Ethernet cables (including one spare).
- Access to an FTP server or USB device for backing up (uploading) or downloading the device configuration or collecting **supportsave** output data (optional).
- A USB drive for collecting **supportsave** output data (optional)

Providing power to the device

About this task

For this procedure, refer to the power supply specifications section in the “Product specifications,” on page 195 for power supply requirements of your device.

Complete the following steps to provide power to the device.



DANGER

Make sure that the power source circuits are properly grounded, then use the power cord supplied with the device to connect it to the power source.

Procedure

1. Remove the protective cover if it is still installed over the top air vents on the port side of the chassis. Refer to “Removing the protective cover” on page 33 for instructions.



CAUTION:

You must remove the protective cover on the port side of the chassis before applying power to the chassis. The chassis can overheat if air vents are blocked with this cover.

2. Install all power supplies provided for your device if not already installed. Refer to “Installing a power supply” on page 158 for procedures.
3. Connect power cords to all installed power supplies.
4. When installing device in a rack, route power cables from power distribution units (PDUs) so they do not cover air vents in chassis.
5. Connect the provided AC power cords to a power source with voltage of 200–240 VAC, 50/60 Hz or optionally to a power source with voltage of 100–120 VAC, 50/60 Hz.

Note:

Use of the high-voltage line (200–240 VAC) is highly recommended because of better power-conversion efficiency. For a “fully-loaded” chassis with maximum supported blades and optics, two power supplies connected to 200–240 VAC are required for full N+N redundancy. At 100 VAC power input, limited configurations are supported. For details on power supplies required for operation and high availability, refer to “Power supply requirements” and “Power consumption” tables in the “Product specifications,” on page 195.

6. Plug the power cords into power supplies. The power supply LED will light green when power is applied. Note that after one power supply is plugged into AC power, LEDs on the remaining installed power supplies will flash green until they also have full power.

The device performs a power-on self-test (POST) each time it is powered on. POST takes approximately 10 minutes, during which time status LEDs on installed blades and other FRUs may display amber. Power LEDs on all FRUs display green when power-on self-test (POST) is complete and all FRUs are functional. You can bypass POST by using the **fastBoot** command. You can also disable POST for successive reboots on the device using the **diagDisablePost** command.

Note:

Do not connect the device to the network until the IP addresses are configured.

7. After POST is complete, verify that the power LEDs on blades and other FRUs are green.

For information about LED patterns, refer to *Monitoring the Device*.

Establishing a serial connection to the device

About this task

To establish a serial connection to the console port on the device, complete the following steps.

Procedure

1. Verify that the device is powered on and that POST is complete by verifying that all power LED indicators on the power supplies, fans, and blades display a steady green light.
2. Remove the shipping cap from the console (I0I0) port on the active CP blade. The active CP is indicated by an illuminated blue LED on the CP blade front panel.

Note: The console, or serial port is intended primarily for the initial setting of the IP address and for service purposes.

3. Use the serial cable provided with the device to connect the console (serial) port on the active CP to a computer workstation.

Note: The active CP is indicated by an illuminated blue LED, labeled "Active," on the CP blade front panel.

If the serial port on the workstation is RJ-45 instead of RS-232, remove the adapter on the end of the serial cable and insert the exposed RJ-45 connector into the RJ-45 serial port on the workstation.

4. Access the device using a terminal emulator application (such as HyperTerminal in a Windows environment or tip in a UNIX environment).
5. Disable any serial communication programs running on the workstation (such as synchronization programs).
6. Open a terminal emulator application (such as HyperTerminal on a PC, or TERM, TIP, or Kermit in a UNIX environment), and configure the application as follows:

- In a Windows environment:

Parameter	Value
Bits per second	9600
Data bits	8
Parity	None
Stop bits	1
Flow control	None

Note: Flow control is not supported on the serial consoles when attached to remote terminal servers and must be disabled on the customer-side remote terminal server and the host-side clients.

- In a UNIX environment, enter the following string at the prompt:

```
tip /dev/ttyb -9600
```

If ttyb is already in use, use ttya -9600 instead.

When the terminal emulator application stops reporting information, press **Enter**. The following login prompt displays:

```
CP0 Console Login:
```

Note: CP0 in the preceding prompt is an example. "CP1" will display if it is the active CP.

7. Log in to the console using *admin* as the default login name and *password* as the default password. As login to the device occurs, you are prompted to change the device passwords.

```
Please change passwords for switch default accounts now.
Use Control-C to exit or press 'Enter' key to proceed.
```

8. Press **Enter** to step through a procedure to change the passwords as shown in the following example. To skip modifying the password, press **Ctrl+C**.

```
-----
for user - admin
Changing password for admin
Enter old password:
Enter new password:
Re-type new password:
passwd: all authentication tokens updated successfully
```

Passwords can be 8 to 40 characters long. They must begin with an alphabetic character. They can include numeric characters, periods (.), and underscores (_) only. Passwords are case-sensitive, and they are not displayed when you enter them on the command line. For more information on passwords, refer to the *Fabric OS Administrator's Guide*.

Configuring the IP addresses

About this task

The device requires three IP addresses, which are configured using the **ipAddrSet** command. IP addresses are required for both CP blades (CP0 and CP1) and for chassis management (shown as SWITCH under the **ipAddrShow** command) in the device.

The default IP addresses and host names for the device are:

- 10.77.77.75 / CP0 (the CP blade in slot 1 at the time of configuration)
- 10.77.77.74 / CP1 (the CP blade in slot 2 at the time of configuration)

Use one of the following formats for IPv4 or IPv6 addressing when entering the IP address using the **ipaddrset** command:

- If you using an IPv4 IP address, enter the IP address in dotted decimal notation as prompted.

```
Ethernet IP Address: [192.168.74.102]
```

- If using an IPv6 address, enter the network information in colon-separated notation as prompted.

```
device:admin> ipaddrset -ipv6 --add 1080::8:800:200C:417A/64
```

Note:

Resetting an IP address while the device has active IP traffic or has management and monitoring tools running, such as DCFM, Fabric Watch, and SNMP, can cause traffic to be interrupted or stopped.

Complete the following steps to set the IP addresses for the device.

Procedure

1. Log into the device through a serial console connection to the active CP blade. The active CP is indicated by an illuminated blue LED on the blade front panel. If you are already logged through a console port, you can determine whether you are logged into the active or standby CP by entering **hashow** at the prompt. The following example shows local login at CP1, which is the active blade.

```
swDir:admin> hashow
Local CP (Slot 2, CP1) : Active, Warm Recovered
Remote CP (Slot 1, CP0) : Standby, Healthy
HA Enabled, Heartbeat Up, HA State Synchronized
```

2. Configure the chassis management IP address by entering the **ipaddrset -chassis** command:

```
swDir:admin> ipAddrSet -chassis
```

Enter required information at the prompts. Specify the **-chassis** IP address. The **-sw 0** IP address is not valid on this device.

Note: The addresses 10.0.0.0 through 10.0.0.255 are reserved and used internally by the device. External IPs must not use these addresses.

Following is example configuration for setting the chassis IP address.

```
swDir:admin> ipaddrset -chassis
DHCP [Off]:
Ethernet IP Address [10.0.0.0]:192.168.1.1
Ethernet Subnetmask [255.0.0.0]:255.255.240.0
IP address is being changed...
```

3. Set up the CP0 IP address by entering the **ipaddrset -cp 0** command:

```
swDir:admin> ipAddrSet -cp 0
```

Enter required information at the prompts. Following is example configuration for setting the CP0 IP address

```
swDir:admin> ipaddrset -cp 0
DHCP [Off]:
Host Name [cp0]:
Ethernet IP Address [10.0.0.0]:192.168.1.2
Ethernet Subnetmask [255.0.0.0]:255.255.260.0
Gateway IP Address [10.0.0.0]:10.38.160.1
IP address is being changed...
Done.
```

4. Set up the CP1 IP address by entering the **ipaddrset -cp 1** command:

```
swDir:admin> ipAddrSet -cp 1
```

Enter required information at the prompts. Following is example configuration for setting the CP1 IP address.

Following is sample configuration for setting the CP1 IP address:

```
swDir:admin> ipaddrset -cp 1
DHCP [Off]:
Host Name [cp0]:
Ethernet IP Address [10.0.0.0]:192.168.3
Ethernet Subnetmask [255.0.0.0]:255.255.230.0
Gateway IP Address [10.0.0.0]:10.38.160.1
IP address is being changed...
Done.
```

Establishing an Ethernet connection to the device

About this task

After using a serial connection to configure the IP addresses for the device, you can connect the active CP blade to the local area network (LAN).

Note: Connecting the CP blades to a private network or VLAN is recommended.

After establishing an Ethernet connection, you can complete the device configuration using a serial console connection, Telnet connection, or management applications, such as Web Tools or IBM Network Advisor.

Perform the following steps to establish an Ethernet connection to the device.

Procedure

1. Remove the shipping plug from the Ethernet port on the active CP blade. The active CP is indicated by an illuminated blue LED on the blade front panel.
2. Insert one end of an Ethernet cable into the Management (MGMT) Ethernet port.
3. Connect the other end to an Ethernet 10/100/1000 BaseT LAN.
4. Complete any additional device configuration procedures for the device using one of the following steps:
 - Log into the device using a serial console connection and **admin** login.
 - Log into the device through a Telnet session using the chassis management IP address and **admin** login.

Setting the domain ID

About this task

Each device in the fabric must have a unique domain ID. The default domain ID is 1. If the device is not powered on until after it is connected to the fabric and the default domain ID is already in use, the domain ID for the new device is automatically reset to a unique value. If the device is connected to the fabric after it has been powered on and the default domain ID is already in use, the fabric segments.

You can use the **fabricShow** command on another device in the fabric to view domain IDs already assigned. Manually configure a unique domain ID using the **configure** command as in the following steps:

Procedure

1. Log into the device using one of the following methods:
 - A serial console connection to the active CP blade. The active CP is indicated by an illuminated blue LED on the blade front panel.
 - A Telnet session using the chassis management IP address.
2. Log into the device using *admin* as your password. If you have not changed the default password, use *password*.
3. Perform the following steps to modify the Domain ID.
 - a. Disable the device by entering the **switchDisable** command.
 - b. Enter the **configure** command. The command prompts display sequentially. Enter a new value or press **Enter** to accept each default value.
 - c. Enter **y** after the "Fabric param" prompt.
Fabric param (yes, y, no, n): [no] y
 - d. Enter a unique domain ID (such as the domain ID used by the previous device, if still available).
Domain: (1..239) [1] 3
 - e. Complete the remaining prompts or press Ctrl+D to accept the remaining settings without completing all the prompts.
 - f. Re-enable the device by entering the **switchEnable** command.

Setting the date and time

About this task

The date and time settings are used for logging events, error detection, and troubleshooting, and hence you should set them correctly. However, device operation does not depend on the date and time; a device with incorrect date or time values still functions properly.

You can synchronize the local time of the principal or primary fabric configuration server (FCS) device to that of an external Network Time Protocol (NTP) server.

Perform the following steps to set the date and time.

Procedure

1. Log into the device using one of the following methods:
 - A serial console connection to the active CP blade. The active CP is indicated by an illuminated blue LED on the blade front panel.
 - A Telnet session using the chassis management IP address.
2. Log into the device using *admin*. If you have not changed the default password, use *password*.
3. Enter the **date** command, using the following syntax:
date "mmddHHMMyy"
The values are:
 - mm is the month; valid values are 01 through 12.
 - dd is the date; valid values are 01 through 31.
 - HH is the hour; valid values are 00 through 23.
 - MM is minutes; valid values are 00 through 59.

- `yy` is the year; valid values are 00 through 99 (values greater than 69 are interpreted as 1970 through 1999, and values less than 70 are interpreted as 2000 through 2069).

```
switch:admin> date
Fri Sep 28 17:01:48 UTC 2016
switch:admin> date "0927123016"
Thu Sep 27 12:30:00 UTC 2016
switch:admin>
```

Setting the time zone

About this task

The default time zone is Coordinated Universal Time (UTC). The time zone needs to be set only once because the value is stored in nonvolatile memory. Use the following procedure to set the time zone. The time zone change will take effect after the next system reboot.

Procedure

1. Log into the device using one of the following methods:
 - A serial console connection to the active CP blade. The active CP is indicated by an illuminated blue LED on the blade front panel.
 - A Telnet session using the chassis management IP address.
2. Log into the device using `admin`. If you have not changed the default password, use `password`.
3. Use one of the following steps for the `tsTimeZone` command.

- Enter `tsTimeZone --interactive` command, enter the appropriate number as shown in the following example, then follow prompts.

```
sw0:admin> tstimezone --interactive
Please identify a location so that time zone rules can be set correctly.
Please select a continent or ocean.
1) Africa
2) Americas
3) Antarctica
4) Arctic Ocean
5) Asia
6) Atlantic Ocean
7) Australia
8) Europe
9) Indian Ocean
10) Pacific Ocean
11) none - I want to specify the time zone using the POSIX TZ format.
Enter number or control-D to quit ?
```

- Enter `tsTimeZone [houroffset [, minuteoffset]]` command as follows:
 - For Pacific Standard Time, enter `tsTimeZone -8,0`.
 - For Central Standard Time, enter `tsTimeZone -6,0`.
 - For Eastern Standard Time, enter `tsTimeZone -5,0`.

Table 7. Example: `tsTimeZone` command parameter selection for the US time zones

Local time	tsTimeZone parameter (difference from UTC)
Atlantic Standard	-4,0
Atlantic Daylight	-3,0
Eastern Standard	-5,0

Table 7. Example: `tsTimeZone` command parameter selection for the US time zones (continued)

Local time	tsTimeZone parameter (difference from UTC)
Eastern Daylight	-4,0
Central Standard	-6,0
Central Daylight	-5,0
Mountain Standard	-7,0
Mountain Daylight	-6,0
Pacific Standard	-8,0
Pacific Daylight	-7,0
Alaskan Standard	-9,0
Alaskan Daylight	-8,0
Hawaiian Standard	-10,0

- Enter the `tsTimeZone` command followed by the time zone, such as US/Pacific, US/Central, or US/Eastern as in the following example.

```
switch_99:Admin> tstimezone US/Pacific
System Time Zone change will take effect at next reboot
```

Synchronizing local time with an external source

About this task

Perform the following steps to synchronize the local time of the principal or primary FCS device with that of an external NTP server.

Procedure

1. Log into the device using one of the following methods:
 - A serial console connection to the active CP blade. The active CP is indicated by an illuminated blue LED on the blade front panel.
 - A Telnet session using the chassis management IP address.
2. Log into the device using `admin`. If you have not changed the default password, use `usepassword`.
3. Enter the `tsClockServer ipaddr` command.

The `ipaddr` variable represents the IP address of the NTP server that the device can access. This argument is optional; by default, the value is "LOCL".

```
switch:admin> tsclockserver 192.168.126.60
Updating Clock Server configuration...done.
Updated with the NTP servers
```

Customizing the chassis and switch name

About this task

The switch name of the device can be up to 31 characters long and must begin with a letter. It can include letters, numbers, hyphens, and underscore characters.

The chassis name and switch name of the device can be up to 31 characters long; can include letters, numbers, hyphens, and underscore characters; and must begin with a letter. The name cannot include spaces.

Note: Changing the name causes a domain address format RSCN to be issued.

Procedure

1. Log into the device using one of the following methods:
 - A serial console connection to the active CP blade. The active CP is indicated by an illuminated blue LED on the blade front panel.
 - A Telnet session using the chassis management IP address.
2. Log into the device using *admin* as your password. If you have not changed the default password, use *password*.
3. Enter **chassisName** followed by the new name.
switch:admin> chassisname Chassis_01

A message displays explaining that the chassis name change is applied and the new name will display at next login. You can enter **chassisName** to verify the new name after login.

4. To change the switch name, enter **switchName** followed by the new name.
swDir:admin> switchName Switch_01
Committing configuration...
Done.
Switch name has been changed.Please re-login into the switch for the change to be applied.

A message displays that the name change is applied and the new name will display at next login. You can enter **switchName** to verify the new name after login.

5. Record the new names for future references.

Verifying the PID mode

About this task

Before connecting the device to the fabric, verify that the WWN-based persistent port identifier (PID) feature on the device matches the other switches in the fabric. This parameter must be identical for all switches in the fabric and is set using the **configure** command.

Procedure

1. Log into the device using one of the following methods:
 - A serial console connection to the active CP blade. The active CP is indicated by an illuminated blue LED on the blade front panel.
 - A Telnet session using the chassis management IP address.
2. Log into the device using *admin* as your password. If you have not changed the default password, use *password*.
3. Check the PID setting using the **configshow** command as in the following example. You can use the `| grep -i pid` qualifier to pinpoint the PID information.
switch:admin> configshow | grep -i pid
fabric.ops.mode.pidFormat:1
fabric.wwnPidMode:1

The 1 indicates that the WWN-based persistent PID feature is enabled. The default value is 0 for disabled.

4. Set the PID mode if necessary using the **configure** command.

Refer to the "Fabric Parameters" section under the "Configure" command in the *Fabric OS Command Reference* for details on configuring WWN Based persistent PID.

Verifying installed licenses and license key

About this task

Depending on the vendor agreement, certain licenses are factory installed on the device. Use the following steps to list installed licenses and to record your license key and chassis ID for future reference.

Procedure

1. Log into the device using one of the following methods:
 - A serial console connection to the active CP blade. The active CP is indicated by an illuminated blue LED on the blade front panel.
 - A Telnet session using the chassis management IP address.
2. Log into the device using *admin* as your password. If you have not changed the default password, use *password*.
3. Enter the **licenseShow** command to determine which licenses are enabled. This will list installed licenses and display a license key, such as `aNYtMJg7tcMZrTZ9JTXBC4SXWLJMY3QfBKYHG`.
4. Enter the **licenseIdShow** command on the active CP blade to obtain the chassis ID. The chassis ID is required to obtain and activate licenses for the device.
5. Record the license key and chassis ID for future reference.

What to do next

Refer to the *Fabric OS Software Licensing Guide* for more information.

Verifying correct operation

About this task

Perform the following steps to verify correct operation of the device.

Procedure

1. Check the LEDs of all power supplies, fans, and blades to verify that all are functional.
2. Log into the device using one of the following methods:
 - A serial console connection to the active CP blade. The active CP is indicated by an illuminated blue LED on the blade front panel.
 - A Telnet session using the chassis management IP address.
3. Log into the device using *admin* as your password. If you have not changed the default password, use *password*.
4. Verify the correct operation of the device by entering the following commands. Copy the output to a file to save the information.

Command	Description
<code>slotshow -m</code>	Displays blades (with model numbers) detected in each slot
<code>slotshow -p</code>	Displays power consumption data and enabled status for installed blades.
<code>psShow</code>	Displays power supply status and information
<code>fanShow</code>	Displays fans status and information
<code>switchShow</code>	Displays switch status and information
<code>fabricShow</code>	Displays information about the device operation in the fabric and general information about the fabric
<code>sLotShow</code>	Displays the current status of each slot in the device
<code>tempShow</code>	Displays temperature status and information
<code>historyShow</code>	Displays the device history
<code>errDump</code>	Displays any errors

Backing up the configuration

About this task

It is recommended that the configuration be backed up on a regular basis to ensure that a complete configuration is available for downloading to a replacement chassis.

Observe the following notes about configuration data:

- Passwords are not saved in the configuration file, and are not uploaded during a configuration upload.
- Besides saving configuration files to an FTP server or local file system, you can save to a USB device by using the **usbstorage** command.

Procedure

1. Log into the device using one of the following methods:
 - A serial console connection to the active CP blade. The active CP is indicated by an illuminated blue LED on the blade front panel.
 - A Telnet session using the chassis management IP address.
2. Log into the device using *admin* as your password. If you have not changed the default password, use *password*.
3. Back up the device configuration using the **configUpload** command. Follow the prompts to upload the configuration to an external host using the file transfer protocol (FTP), secure copy protocol (SCP), or secure FTP (SFTP), or save the configuration to the local file system on device or attached USB device.

```
sb_70:admin> configupload
Protocol (scp, ftp, local) [ftp]:
Server Name or IP Address [host]: 192.168.0.100
User Name [user]: anonymous
Path/File name [<home dir>/config.txt]: /dumps/supportsave/pz/switch85/G20-1.txt
Section (all|chassis|switch [all]): all
configUpload complete: All selected config parameters are uploaded
```

4. Back up the virtual fabric configuration using the **configUpload -vf** command. For more information on using the **configUpload** and **configUpload -vf** command, refer to the *Fabric OS Command Reference*.

5. Enter the following commands for additional configuration information that you can save to files:
 - **configShow**
 - **ipaddrShow**
 - **licenseShow**
 - **switchShow**

Powering down the chassis

About this task

Perform the following steps to power down the chassis.

Procedure

1. Shut down the chassis using the **sysShutdown** command.

```
switch::admin> sysshutdown
This command will shutdown the operating systems on your switch.
You are required to power-cycle the switch in order to restore operation.
Are you sure you want to shutdown the switch [y/n]?y
HA is disabled
Stopping blade 1
Shutting down the blade....
Stopping blade 2
Shutting down the blade....
Stopping blade 8
Shutting down the blade....
Broadcast message from root (pts/1) Tue Aug 23 14:23:06 2010...
The system is going down for system halt NOW !!
```

Note: If you do **not** use the **sysshutdown** command and you sequence power off on power distribution units (PDU) with a few seconds between power-offs, be aware that a low-power condition will be detected and logged along with possible blade power-offs before shutdown. This is an expected error condition due to delays in powering down PDUs without halting the control processors first using **sysShutdown**

2. Power off the chassis by disconnecting all power cords or switching off rack power source.

Note that power supply LEDs will continue to flash green briefly after disconnecting power until power supply is completely off.

Chapter 5. Installing Transceivers and Cables

This chapter provides the following information:

- “Supported transceivers and cables”
- “Time and items required” on page 52
- “Precautions specific to transceivers and cables” on page 53
- “Cleaning the fiber-optic connectors” on page 53
- “Cable management” on page 54
- “Installing an SFP+ transceiver” on page 54
- “Replacing an SFP+ transceiver” on page 56
- “Installing a QSFP transceiver” on page 57
- “Replacing a QSFP transceiver” on page 58
- “Verifying the operation of new transceivers” on page 60

Supported transceivers and cables

The following table is a general reference to the types of transceivers supported on device blades.

Table 8. Supported transceivers and cables

Blade	Transceiver Type	Auto-negotiate/ Fixed	Speeds supported (Gbps)
FC32-48 port blade	32 Gbps SFP28, SWL, LWL	Auto negotiate	8, 16, 32
	16 Gbps SFP+, SWL, LWL, ELWL	Auto negotiate	4, 8, 16
	10 Gbps SFP+, SWL, LWL	Fixed	10
SX6 extension blade	32 Gbps SFP28, SWL, LWL	Auto negotiate	8, 16, 32
	16 Gbps SFP+, SWL, LWL, ELWL	Auto negotiate	4, 8, 16
	10 Gbps, SFP+, SWL, LWL	Fixed	10
	10 GbE SFP+, SR, LR	Fixed	10
	1 GbE SFP, Copper	Fixed	1
	1 GbE SX SFP, LX SFP, and CWDM SFP+	Fixed	1
	1 GbE CWDM SFP+	Fixed	1
	40 GbE QSFP, SR4/LR4/ER4	Fixed	40
CR32-8 core routing blade	4x16 Gbps QSFP, SWL,	Fixed (each 16 Gbps channel)	16
	4x32 Gbps QSFP28, SWL	Fixed (each 32 Gbps channel)	32
	4x16 Gbps 2 km QSFP, LWL	Fixed (each 16 Gbps channel)	16

The following notes apply to QSFP transceivers on core routing blades.

- You cannot connect an ICL between a 4x32 Gbps QSFP on a SAN512B-6 core blade and a 16-Gbps QSFP on a DCX 8510 core routing blade. You must use a 4x16 Gbps QSFP on the SAN512B-6 blade.
- The 4x32 Gbps QSFP28 transceiver has four links that operate at 32 Gbps to achieve a 128 Gbps link speed. The 4x16 Gbps QSFP+ transceiver has four links that operate at 16 Gbps to achieve a 64 Gbps link speed. The cables come in specific predetermined fixed lengths that are qualified by IBM.

For current information on transceivers and cables supported by this device, refer to the *Fibre Channel Transceiver Support Matrix* on www.brocade.com and to the current *Fabric OS Release Notes*:

Core routing blades

QSFPs installed in core routing blades are used for connecting inter-switch links (ICLs) between SAN512B-6 and SAN256B-6 switches or between SAN512B-6 or SAN256B-6 and SAN384B-2 or SAN768B-2 switches. Interconnecting these devices increases the number of usable ports for device connections.

Following are types of QSFPs installed in core routing blades:

- Separate MTP cable and transceiver. The transceiver is inserted into the blade port and the cable plugs into a QSFP on the other end of the ICL.

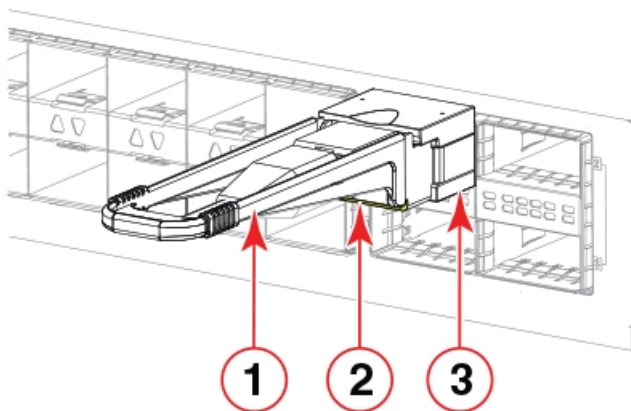

Figure 14. QSFP transceiver with separate cable

- 1 - Pull tab
- 2 - QSFP cable
- 3 - QSFP transceiver

Note: If the fiber optic cables are not connected to the transceivers, make sure the rubber sealing gaskets are plugged into the transceivers.

- 2 km LWL 16 Gbps QSFP transceiver with integrated MTP cable. The transceiver is inserted into the blade port connector and integrated cable plugs into a QSFP on the other end of the ICL, a patch panel, or a patch cable.

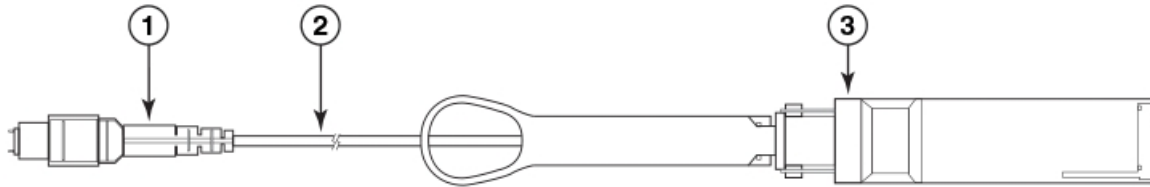

Figure 15. 2 km QSFP 16 Gbps with integrated cable

- 1 - MTP 1x12 fiber male connector
- 2 - Integrated 3 meter MTP cable
- 3 - Transceiver with pull-tab

Follow these guidelines for using QSFPs when connecting ICLs. Refer to “Installing a QSFP transceiver” on page 57 to install cables and QSFP transceivers.

- The QSFP ports on the core switch blades can be used only with an inter-chassis link (ICL) license. After the addition or removal of a license, the license enforcement is performed on the ports only when the **portdisable** and **portenable** commands are issued on the ports. An ICL license must be installed on all SAN512B-6 and SAN256B-6 switches forming the ICL connection. Up to nine neighboring switches can be connected with the MTP cables.
- The 32 Gbps QSFP28 transceivers on SAN512B-6 core routing blades only operate at 32 Gbps and cannot be configured at 16 Gbps for Fabric OS v8.0.1. Therefore, you cannot connect an ICL between a 32 Gbps transceiver on a SAN512B-6 core blade and a 16 Gbps QSFP transceiver on a SAN384B-2 or SAN768B-2 core routing blade. You must connect between 16 Gbps transceivers on each blade.
- An off-the-shelf MTP cable up to 100 meters can be used as an ICL cable when using the standard SWL optics. The 2 km 16 Gbps QSFP with LWL optics has an integrated 3 meter single-mode pigtail with a male MTP connector for connectivity to a patch panel or female terminated MTP patch cable to achieve up to 2 km distances. Refer to for more information.
- IBM supports fully populating a switch with ICL connections using a mixture of 50 and 100 m SWL optics and 16 Gbps 2 km LWL optics.
- Any number of ICL ports can be used for 2 km distances when using 2 km LWL 16 Gbps QSFPs and configuring 20 buffer credits per virtual channel. There are no limitations on the number of ICL ports if all ICL distances are a few hundred meters.

On the core routing blade faceplates, QSFP ports belonging to the same trunking groups are indicated with the same color border under the ports. These colors are also applied to the port map labels on each blade faceplate to indicate ports belonging to the same trunking groups.

For details on the following subjects, refer to the "Inter-Chassis Links" section of the *Fabric OS Administrator's Guide*:

- ICL topologies
- ICL trunking
- Configuring ICLs between SAN512B-6 and SAN256B-6 switches
- Configuring ICLs between SAN512B-6 or SAN256B-6 switches and SAN384B-2 or SAN768B-2 switches

2 km LWL QSFPs

All 16 ICL ports can be used for 2km distances when we configure 20 buffer credits are configured per virtual channel.

The 2 km LWL QSFP, is a hot-swappable, low-voltage (3.3 V) digital diagnostic optical transceiver that supports high-speed serial links over parallel single-mode optical fibers at signaling rates up to 4×14.025 Gbps. The QSFP is integrated with a 3 m ribbon fiber cable with a male MTP 1×12 connector. The QSFP supports 2 km link length on parallel single-mode fiber.

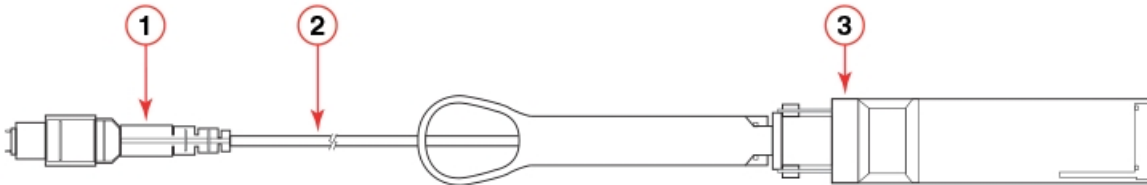

Figure 16. 2 km LWL QSFP transceiver with integrated cable

- 1 - MTP 1×12 fiber male connector
- 2 - Integrated 3-meter MTP cable
- 3 - Transceiver with pull-tab

Following are cabling options and recommendations:

- Connect the 3-meter integrated single mode transceiver cable directly to a female-terminated connector in a patch panel or patch cable using a key-up/key-down MPO/MTP coupler.
- Use female-to-female patch cable with the following specifications:
 - Single-mode (not OM3 MMF or OMM MMF)
 - MTP/MPO 1×12 fiber
 - MTP female angled polished connector (APC)
 - Key-up/key-down connectors for polarity



Figure 17. Female-to-female patch cable for QSFP connections

Time and items required

The installation or replacement procedure for one transceiver takes less than 5 minutes. Ensure that the following items are available:

- Required number of compatible power cables
- Required number of supported IBM-branded transceivers
- Required number of compatible fiber-optic cables
- Optical transceiver extraction tool (for 10 Gbps transceiver only)

Note: Most devices come with a transceiver extraction tool and holster. The extraction tool is designed to remove transceivers from modules where the space is limited.



Figure 18. Optical transceiver extraction tool

Precautions specific to transceivers and cables



CAUTION:
All fiber-optic interfaces use Class 1 lasers.



CAUTION:
Use only optical transceivers that are qualified by IBM and comply with the FDA Class 1 radiation performance requirements defined in 21 CFR Subchapter I, and with IEC 825 and EN60825. Optical products that do not comply with these standards might emit light that is hazardous to the eyes.

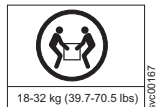

CAUTION:
Do not use the port cover tabs to lift the module. They are not designed to support the weight of the module, which can fall and be damaged.



CAUTION:
Before plugging a cable into any port, be sure to discharge the voltage stored on the cable by touching the electrical contacts to ground surface.

Cleaning the fiber-optic connectors

To avoid problems with the connection between the fiber-optic transceiver (SFP+ or QSFP) and the fiber cable connectors, IBM strongly recommends cleaning both connectors each time you disconnect and reconnect them. Dust can accumulate on the connectors and cause problems such as reducing the optic launch power.

A fiber-optic reel-type cleaner is recommended for cleaning the fiber cable connectors. When not using an SFP+, or QSFP connector, make sure to keep the protective covering in place.

Cable management

The minimum radius that a 50 micron cable can be bent under full tensile load is 5.1 cm (2 in.). For a cable under no tensile load, that minimum is 3.0 cm (1.2 in.). Cables can be organized and managed in a variety of ways, for example, using cable channels on the sides of the rack or patch panels to minimize cable management. Following is a list of additional recommendations:

- Plan for rack space required for cable management before installing the switch.
- Leave at least 1 m (3.28 ft) of slack for each port cable. This provides room to remove and replace the switch, allows for inadvertent movement of the rack, and helps prevent the cables from being bent to less than the minimum bend radius.
- If you are using ICL Trunking, consider grouping cables by trunking groups. The cables used in trunking groups must meet specific requirements, as described in the *Fabric OS Administrator's Guide*.
- For easier maintenance, label the fiber-optic cables and record the devices to which they are connected.
- Keep LEDs visible by routing port cables and other cables away from the LEDs.
- Do not route the cables in front of air vents.
- Use Velcro® type straps to secure and organize fiber-optic cables.
- Route the cables away from LEDs to keep them visible.
- The cable management comb attaches to the lower part of the chassis and allows for simple cable management. The comb can be installed without service disruption.



CAUTION:

Before plugging a cable into any port, be sure to discharge the voltage stored on the cable by touching the electrical contacts to ground surface.

Note: Do not use tie wraps with optical cables because they are easily overtightened and can damage the optic fibers.

Installing an SFP+ transceiver

About this task

The device supports only IBM-qualified transceivers. If you use an unqualified transceiver, the **switchshow** command output shows the port in a Mod_Inv state. Fabric OS also logs the issue in the system error log. To insert an SFP+ transceiver, complete the following steps:

Note: Always use the pull tab to insert or remove 16 Gbps and 32 Gbps transceivers as they might be hot.

Procedure

1. Perform one of the following steps, depending on your transceiver type.
 - If transceiver has a pull tab (16- and 32-Gbps SFP+ transceivers), use the pull tab to help push the transceiver into the port until it is firmly seated and the latching mechanism clicks.

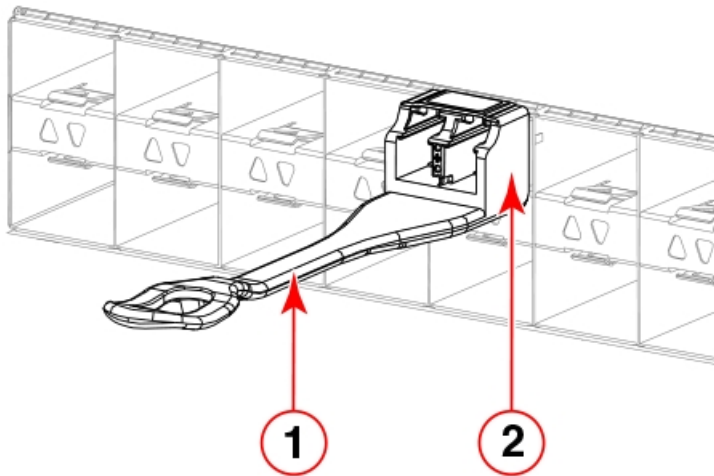
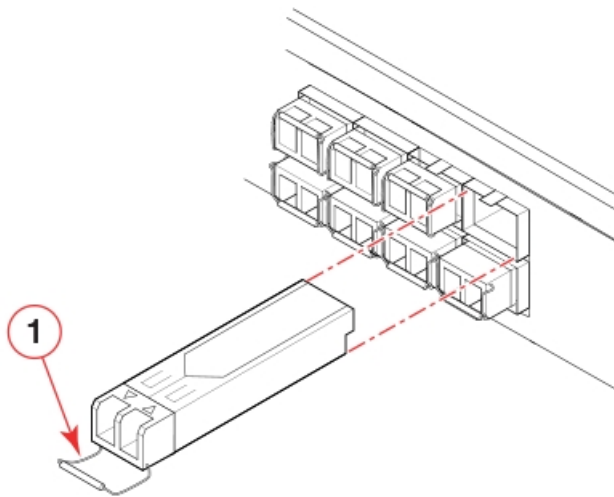

Figure 19. Installing an SFP+ transceiver with pull tab into blade port

- 1 - Pull tab
- 2 - Transceiver

- If transceiver has a bail latch mechanism (10 GbE transceivers), ensure that the bail (wire handle) is in the unlocked position, grasp the transceiver, and push it into the port until firmly seated. Close the bail to latch the transceiver in the slot.



- 1 - Bail

Figure 20. Installing an SFP+ transceiver with bail latch into blade port

Transceivers are keyed so that they can only be inserted with the correct orientation. If a transceiver does not slide in easily, ensure that it is correctly oriented.

2. Position a cable so that the key (the ridge on one side of the cable connector) is aligned with the slot in the transceiver. Insert the cable into the transceiver until the latching mechanism clicks.

Note: Cables are keyed so that they can be inserted in only one way. If a cable does not slide in easily, ensure that it is correctly oriented. Do not insert any unsupported cable intended for an other type of transceiver into a regular SFP+ transceiver. You may damage the cable as well as the transceiver.

Replacing an SFP+ transceiver

About this task

Complete the following steps to remove and then install a new SFP+ transceiver.

Note: The 16- and 32-Gbps SFP+ transceivers do not have bails but pull tabs. Always use the pull tab to insert or remove the SFP+ transceivers, as the transceiver might be hot.

Procedure

1. Remove any cables that are inserted into the transceiver.
2. To remove the transceiver, perform one of the following steps, depending on your transceiver type.
 - If transceiver has a pull tab (16- and 32-Gbps SFP+ transceivers), grasp the pull tab and pull the transceiver straight out from the port.

Note: Grasp the pull tab near the body of the transceiver to reduce the chances of bending the pull tab. As the transceiver may be hot, avoid touching it.

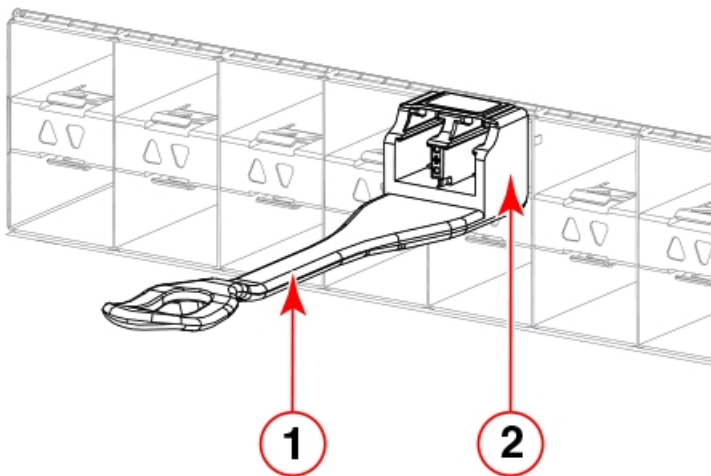

Figure 21. Replacing a SFP+ optical transceiver with pull tab into blade port

1 - Pull tab

2 - Transceiver

- If transceiver has a bail latch mechanism (10 GbE transceivers), unlatch from the port by pulling the bail (wire handle) away from its pivot point using your fingers or the hooked end of the transceiver extraction tool. Pull the transceiver out from the port slightly using the bail, and then grasp the transceiver with your fingers and slide it straight out of the port.

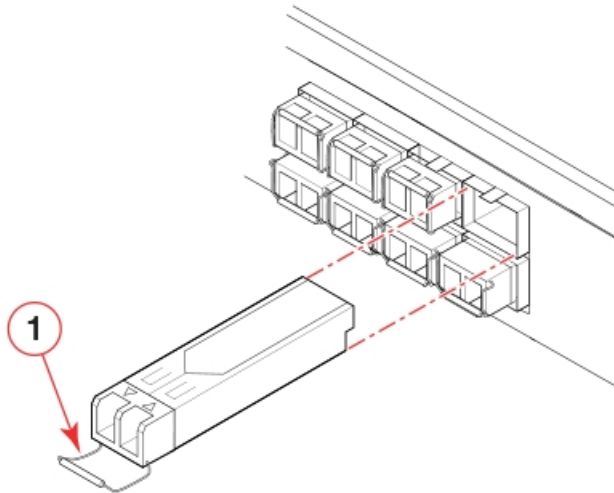

Figure 22. Installing an SFP+ transceiver with bail latch into blade port

1 - Bail

3. To install the transceiver, perform one of the following steps depending on your transceiver type:
 - If transceiver has a pull tab (16 and 32 Gbps SFP+ transceivers), use the pull tab to help push the transceiver into the port until it is firmly seated and the latching mechanism clicks.
 - If transceiver has a bail latch mechanism (10 GbE transceivers), ensure that the bail (wire handle) is in the unlocked position, grasp the transceiver, and push it into the port until firmly seated. Close the bail to latch the transceiver in the slot.

Transceivers are keyed so that they can only be inserted with the correct orientation. If a transceiver does not slide in easily, ensure that it is correctly oriented.

4. Position a cable so that the key (the ridge on one side of the cable connector) is aligned with the slot in the transceiver. Insert the cable into the transceiver until the latching mechanism clicks.

Cables are keyed so that they can be inserted in only one way. If a cable does not slide in easily, ensure that it is correctly oriented.

Installing a QSFP transceiver

About this task

The device supports only IBM-qualified transceivers. If you use an unqualified transceiver, the `switchshow` command output shows the port in a `Mod_Inv` state. Fabric OS also logs the issue in the system error log. Also note the following:

- Each QSFP contains four individual 16 Gbps or 32 Gbps ports. Be aware that any problems with one port could affect all four ports in the quad if the QSFP must be replaced.
- Although installation and removal procedures are the same for QSFP transceivers installed in port blades and extension blades, these transceivers are not interchangeable between the two blade types.
- Some QSFPs, such as the 4x16 Gbps 2 km QSFP, have an integrated cable attached. You do not need to install a separate cable.

To insert an QSFP transceiver and cable, complete the following steps.

Procedure

1. Push the transceiver into the port using the pull tab. Transceivers are keyed so that they can only be inserted with the correct orientation. If a transceiver does not slide in easily, ensure that it is correctly oriented. Push the correctly oriented transceiver into the port until it is firmly seated and the latching mechanism clicks.

Note: Always use the transceiver pull tab to insert or remove the QSFP transceivers, as the transceiver might be hot.

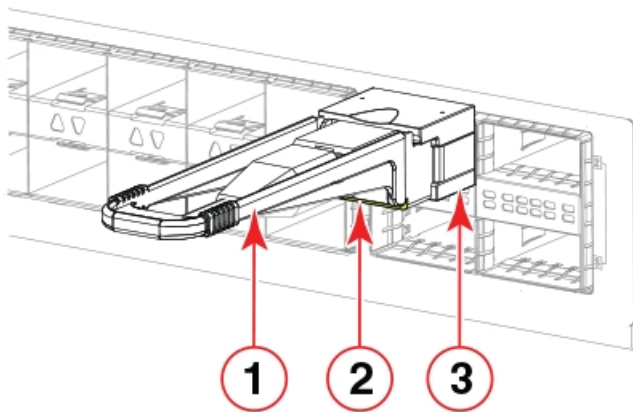

Figure 23. Installing a QSFP transceiver into blade port

- 1 - Pull tab
- 2 - QSFP cable
- 3 - QSFP transceiver

The port LED initially blinks amber after installation, then displays steady amber.

2. Position the cable so that the key (the ridge on one side of the cable connector) is aligned with the slot in the transceiver. Insert the cable into the transceiver until the latching mechanism clicks.

Note: If your transceiver has an integrated cable, you will not need to install a cable.

The port LED displays steady amber until both ends of the cable are inserted and the link is established. When the link is fully established, the LED displays steady green.

Note: Cables are keyed so that they can be inserted in only one way. If a cable does not slide in easily, ensure that it is correctly oriented. Do not insert any unsupported cable intended for an other type of transceiver into a regular QSFP transceiver. You may damage the cable as well as the transceiver.

3. Organize cables to avoid covering LEDs and air vents. Refer to “Cable management” on page 54.

Replacing a QSFP transceiver

About this task

The device supports only IBM-qualified transceivers. If you use an unqualified transceiver, the `switchshow` command output shows the port in a `Mod_Inv` state. Fabric OS also logs the issue in the system error log. Also note the following:

- Each QSFP contains four individual 16 Gbps or 32 Gbps ports. Be aware that any problems with one port could affect all four ports in the quad if the QSFP must be replaced.
- Although installation and removal procedures are the same for QSFP transceivers installed in port blades and extension blades, these transceivers are not interchangeable between the two blade types.
- Some QSFPs, such as the 4x16 Gbps 2 km QSFP, have an integrated cable attached. You do not need to install a separate cable.

Complete the following steps to remove and then install a new QSFP transceiver.

Procedure

1. Remove any cables that are inserted into the transceiver.

Note: If your transceiver has an integrated cable, you cannot remove the cable.

2. Grasp the transceiver pull tab and gently pull the transceiver straight out from the port.

Note: Grasp the pull tab near the body of the transceiver to reduce the chances of bending the pull tab. As the transceiver may be hot, always use the pull tab and avoid touching the transceiver body.

3. To insert the replacement transceiver, use the pull tab to carefully push the transceiver into the port. Transceivers are keyed so that they can only be inserted with the correct orientation. If a transceiver does not slide in easily, ensure that it is correctly oriented. Gently push the correctly oriented QSFP transceiver until the latching mechanism clicks.

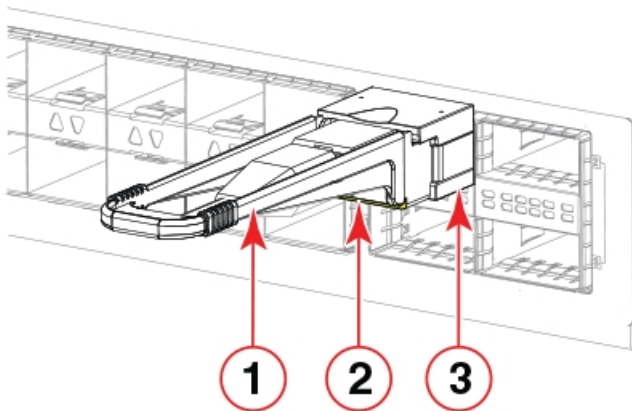

Figure 24. Installing a QSFP optical transceiver into blade port

- 1 - Pull tab
- 2 - QSFP cable
- 3 - QSFP transceiver

The port's status LED initially blinks amber after installation, then displays steady amber.

4. Position a cable so that the key (the ridge on one side of the cable connector) is aligned with the slot in the transceiver. Insert the cable into the transceiver until the latching mechanism clicks.

Note: If your transceiver has an integrated cable attached, you will not install a cable.

The port's status LED displays steady amber until both ends of the cable are inserted and the link is established. When the link is fully established, the LED displays steady green.

Note: Cables are keyed so that they can be inserted in only one way. If a cable does not slide in easily, ensure that it is correctly oriented.

5. Organize cables to avoid covering LEDs and air vents. Refer to “Cable management” on page 54.

Verifying the operation of new transceivers

About this task

You can use the following commands to verify if the transceivers are working correctly:

- **sfpShow**
- **switchShow**
- **switchshow-slot** *slot*, where *slot* is slot number
- **switchshow -qsfp**
- **errDump**
- **fabricShow**

Example

For output examples and additional information on Fabric OS commands, refer to “Using monitoring commands” on page 77 and the *Fabric OS Command Reference*.

For more information about error messages, refer to the *Fabric OS Message Reference*.

Chapter 6. Monitoring the switch

This switch is engineered for high reliability, high availability, and enhanced serviceability (RAS) and requires no routine operational steps or maintenance. This chapter provides information about determining the status of each component using LEDs and CLI commands. Refer to the *Web Tools Administrator's Guide* and the *Fabric OS Administrator's Guide* for additional information.

This chapter provides the following information:

- “Interpreting port blade LEDs”
- “Interpreting extension blade LEDs” on page 64
- “Interpreting control processor blade LEDs” on page 66
- “Interpreting core routing blade LEDs” on page 69
- “Interpreting WWN card LEDs” on page 70
- “Interpreting power supply LEDs” on page 71
- “Interpreting fan assembly LEDs” on page 74
- “Interpreting POST and boot results” on page 76
- “Using monitoring commands” on page 77
- “Running diagnostic tests” on page 95

Interpreting port blade LEDs

Refer to the following illustration and table to interpret the LED patterns for the FC32-48 blade. The LED patterns will temporarily change during POST and other diagnostic tests.

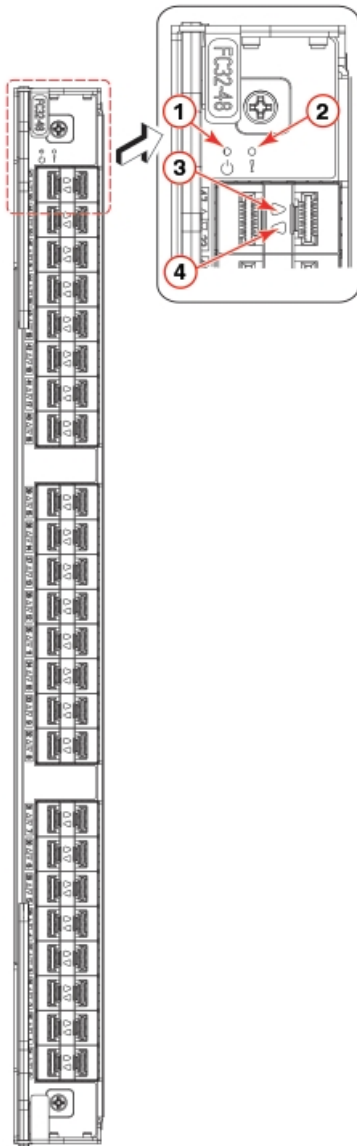

Figure 25. FC32-48 port blade LEDs

- 1 - Blade power LED
- 2 - Blade status LED
- 3 - Status LED for right FC port
- 4 - Status LED for left FC port

The following table describes the port blade LED patterns and the recommended actions for those patterns.

Table 9. Port blade LED descriptions



LED purpose	Color	Status	Recommended action
Power 	Steady green	Blade is operational.	No action required.
	No light (LED is off)	Blade is not powered on.	Ensure that the blade is firmly seated, with ejectors pushed in fully to center of blade and captive screw for each ejector fully tightened.

Table 9. Port blade LED descriptions (continued)

LED purpose	Color	Status	Recommended action
Status 	No light (LED is off)	Blade is either healthy or does not have power.	Verify that the power LED is on.
	Steady amber	Blade is faulty.	Ensure that the blade is firmly seated and check the status by entering the slotShow command. If LED remains amber, consult the device supplier.
	Slow-flashing amber (on 2 seconds, then off 2 seconds)	Blade is not seated correctly or is faulty.	Pull the blade out and reseal it. If LED continues to flash, replace the blade.
	Fast-flashing amber (on 1/2 second, then off 1/2 second)	Environmental range exceeded.	Check for out-of-bounds environmental condition and correct it.
FC port Status	No light (LED is off)	Port has no incoming power, or there is no light or signal carrier detected.	Verify that the power LED is on, check the transceiver and cable.
		Polling is in progress.	Allow 60 seconds for polling to complete.
		Connected device is configured in an offline state.	Verify the status of the connected device.
	Steady green	Port is online (connected to an external device) but has no traffic.	No action required.
	Slow-flashing green (on 1 second, then off 1 second)	Port is online but segmented, indicating a loopback plug or cable or an incompatible switch.	Verify that the correct device is attached to the chassis.
	Fast-flashing green (on 1/4 second, then off 1/4 second)	Port is in internal loopback (diagnostic).	No action required.
	Flickering green	Port is online, with traffic flowing through port.	No action required.
	Steady amber	Port is receiving light or signal carrier, but it is not online yet.	Reset the port from the workstation using the portEnable or portCfgPersistentEnable command.
	Slow-flashing amber (on 2 seconds, then off 2 seconds)	Port is disabled due to diagnostic tests or portDisable or portCfgPersistentEnable command.	Reset the port from the workstation using the portEnable or portCfgPersistentEnable command.
	Fast-flashing amber (on 1/2 second, then off 1/2 second)	Transceiver or port is faulty.	Change the transceiver or reset the switch from the workstation.
Alternating green/amber	Port is beaconing.	No action.	

Interpreting extension blade LEDs

Refer to the following illustration and table to interpret the LED patterns on the SX6 extension blade. The LED patterns may temporarily change during POST and other diagnostic tests.

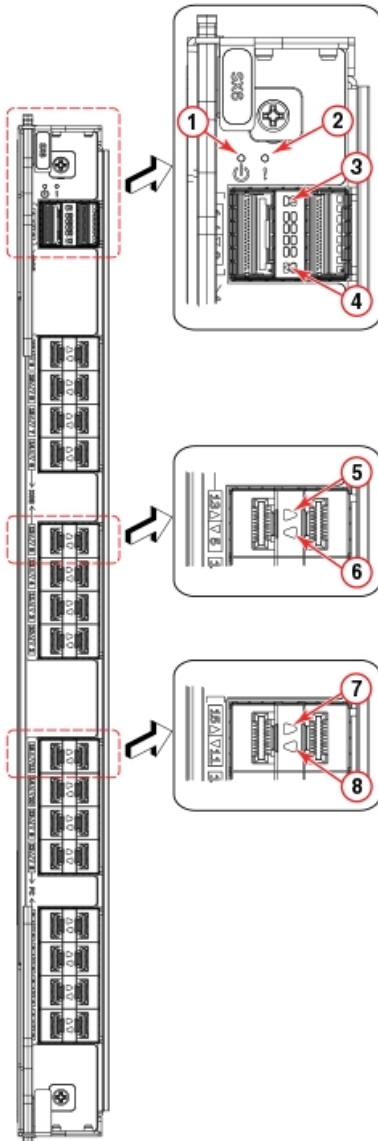

Figure 26. SX6 Extension blade LEDs

- 1 - Blade power LED
- 2 - Blade status LED
- 3 - Right 40 GbE QSFP (port 0) status LED
- 4 - Left 40 GbE QSFP (port 1) status LED
- 5 - Right 1 or 10 GbE port status LED
- 6 - Left 1 or 10 GbE port status LED
- 7 - Right FC port status LED
- 8 - Left FC port status LED

The following table describes the extension blade LED patterns and the recommended actions for those patterns.

Table 10. Extension blade LED descriptions



LED purpose	Color	Status	Recommended action
Power 	Steady green	Blade is operational.	No action required.
	No light (LED is off)	Blade is not powered on.	Ensure that the blade is firmly seated, with ejectors pushed in fully to center of blade and captive screw for each ejector fully tightened.
Status 	No light (LED is off)	Blade is either healthy or does not have power.	Verify that the power LED is on.
	Steady amber	Blade is faulty or initializing.	Ensure that the blade is firmly seated and check the status by entering the s1otShow command. If LED remains amber, consult the device supplier.
	Blinking amber and green.	Attention. Blade is not seated correctly or is faulty.	Pull the blade out and reseal it. If LED continues to flash, replace the blade.
	Green	Blade is operational.	No action required.
GbE port status	No light (LED is off)	Port has no incoming power, or is offline.	Verify that the power LED is on, check the transceiver and cable.
	Steady green	Port is online but has no traffic.	No action required.
	Blinking green	Port is online, with traffic flowing through port.	No action required.
	Steady amber	Transceiver or port has error or is faulty.	Change the transceiver or reset the switch from the workstation.

Table 10. Extension blade LED descriptions (continued)

LED purpose	Color	Status	Recommended action
FC port status	No light (LED off)	Port has no incoming power, or there is no light or signal carrier detected.	Verify that the power LED is on, check the transceiver and cable.
		Polling is in progress.	Allow 60 seconds for polling to complete.
		Connected device is configured in an offline state.	Verify the status of the connected device.
	Steady green	Port is online (connected to an external device) but has no traffic.	No action required.
	Slow-flashing green (on 1 second, then off 1 second)	Port is online but segmented, indicating a loopback plug or cable or an incompatible switch.	Verify that the correct device is attached to the chassis.
	Fast-flashing green (on 1/4 second, then off 1/4 second)	Port is in internal loopback (diagnostic).	No action required.
	Flickering green	Port is online, with traffic flowing through port.	No action required.
	Steady amber	Port is receiving light or signal carrier, but it is not online yet.	Reset the port from the workstation using the portEnable or portCfgPersistentEnable command.
	Slow-flashing amber (on 2 seconds, then off 2 seconds)	Port is disabled due to diagnostic tests or portDisable or portCfgPersistentEnable command.	Reset the port from the workstation using the portEnable or portCfgPersistentEnable command.
	Fast-flashing amber (on 1/2 second, then off 1/2 second)	Transceiver or port has error or is faulty.	Change the transceiver or reset the switch from the workstation.
Alternating green and amber	Port is bypassed.	Reset the port from the workstation using the portEnable or portCfgPersistentEnable command.	

Interpreting control processor blade LEDs

Refer to the following illustration and table to interpret the LED patterns on the CPX6 blade. The LED patterns may temporarily change during POST and other diagnostic tests.

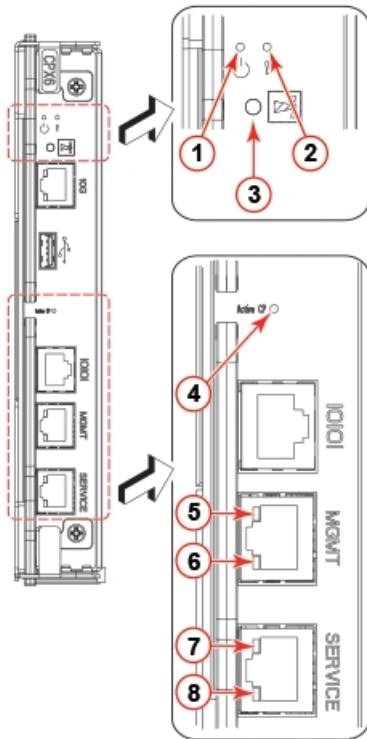

Figure 27. Control processor blade (CPX6)

- 1 - Blade power LED
- 2 - Blade status LED
- 3 - Chassis beacon LED
- 4 - Active (blue) CP LED
- 5 - 10/100/1000 Mb/s Ethernet port (MGMT) link status LED
- 6 - 10/100/1000 Mb/s Ethernet port (MGMT) link activity LED
- 7 - 10/100/1000 Mb/s Ethernet port (SERVICE) link status LED
- 8 - 10/100/1000 Mb/s Ethernet port (SERVICE) link activity LED

Note: The 10 Gbps Base-T RJ45 Ethernet port, shown below the blade beacon LED, is reserved for future use.

The following table describes the CP blade LED patterns and the recommended actions for those patterns.

Table 11. CP blade LED descriptions

LED purpose	Color	Status	Recommended action
Power 	Steady green	CP blade is on.	No action required.
	No light (LED is off)	CP blade is not on.	Ensure that the blade is firmly seated and has power.

Table 11. CP blade LED descriptions (continued)

LED purpose	Color	Status	Recommended action
Attention 	No light (LED is off)	CP blade is either healthy or does not have power.	Verify that the power LED is on.
	Steady amber	If on for more than 5 seconds, the CP blade is faulty.	Ensure that the blade is firmly seated and the switch has completed booting. If LED remains amber, consult the device supplier.
	Slow-flashing amber (on 2 seconds, then off 2 seconds)	CP blade is not seated correctly or is faulty.	Pull the blade out and reseat it. If the LED continues to flash, replace the blade.
	Fast-flashing amber (on 1/2 second, then off 1/2 second)	Environmental range exceeded.	Check for out-of-bounds environmental condition and correct it.
Beacon	Steady white	LED illuminates white on both CP blades when chassisbeacon 1 is issued from management interface to locate chassis in equipment racks. To turn off beaconing, issue the chassisbeacon 0 .	No action required.
Ethernet link status (10 Gb/s port)	No light (LED is off)	Either an Ethernet link is not detected, or the blade does not have incoming power.	Ensure that the blade has power, the Ethernet cable is firmly seated, and the connected device is functioning.
	Blinking green	Activity is present on link.	No action required.
Ethernet link activity (10 Gb/s port)	No light (LED is off)	No activity on link.	Ensure that the blade has power, the Ethernet cable is firmly seated, and the connected device is functioning.
	Blinking green	Activity is present on link.	No action required.
Active CP	Steady blue	Active CP blade.	No action required.
	No light (LED is off)	CP blade is either booting, negotiating to be active, or is the standby CP blade.	No action required.
Ethernet link status (10/100/1000 Mb/s port)	No light (LED is off)	Ethernet link speed is 10 Mb/s or link is not established.	Ensure that the CP has power. NOTE: To force a persistent Ethernet link speed, enter the ifModeSet command.
	LED is on	Ethernet link speed is 100/1000 Mb/s. Ethernet link is healthy and traffic is flowing through port.	No action required.

Table 11. CP blade LED descriptions (continued)

LED purpose	Color	Status	Recommended action
Ethernet link activity (10/100/1000 Mb/s port)	No light (LED is off)	No activity on link.	Ensure that the blade has power, the Ethernet cable is firmly seated, and the connected device is functioning.
	Blinking green	Activity is present on link.	No action required.

Interpreting core routing blade LEDs

Refer to the following illustration and table to interpret the LED patterns on the CR32-8 blade. The LED patterns may temporarily change during POST and other diagnostic tests.

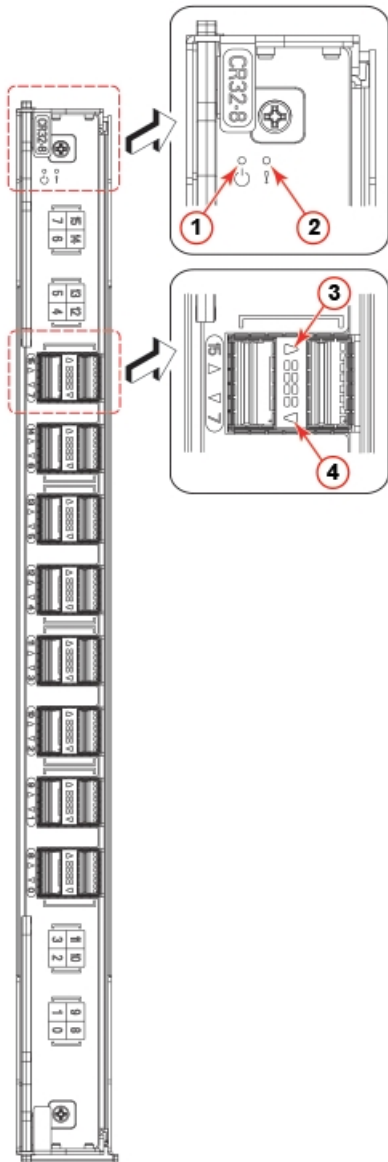



Figure 28. CR32-8 core routing blade LEDs

1 - Blade power LED

- 2 - Blade status LED
- 3 - QSFP status LED for right QSFP port
- 4 - QSFP status LED for left QSFP port

Table 12. Core routing blade LED descriptions

LED purpose	Color	Status	Recommended action
Power 	Steady green	Blade is on.	No action required.
	No light (LED is off)	Blade is not on.	Ensure that the blade is firmly seated and has power.
Status 	No light (LED is off)	Blade is either healthy or does not have power.	Verify that the power LED is on.
	Steady amber	Blade is faulty or the switch is still booting.	Ensure that the blade is firmly seated and the switch has completed booting. If the LED remains amber, consult the supplier for your device.
	Slow-flashing amber (on 2 seconds, then off 2 seconds)	Blade is not seated correctly or is faulty.	Pull the blade out and reseat it. If the LED continues to flash, replace the blade.
	Fast-flashing amber (on 1/2 second, then off 1/2 second)	Environmental range exceeded.	Check for out-of-bounds environmental condition and correct it.
QSFP port status LED	No light (LED is off)	No QSFP module, all four QSFP ports are disabled	No action needed if the QSFP is not installed or verify that the QSFP is fully inserted.
	Steady amber	QSFP module is in, all four ports have no signal/no sync.	Ensure that the cable is properly connected. If the LED remains amber, consult the supplier for your device.
	Blinking amber	Port is disabled or faulted, FC link activity, segmented, loopback mode, also during transition between cable plug in and all four ports online.	Check for console messages or wait for all four ports to come online.
	Steady green	QSFP module is in and all ports are online.	No action needed.

Interpreting WWN card LEDs

Refer to the following illustration and table to interpret the LED patterns of installed WWN cards. LEDs for WWN card 1 and WWN card 2 are located on the WWN card bezel between the power supplies on the nonport side of the device. The LED patterns may temporarily change during POST and other diagnostic tests.

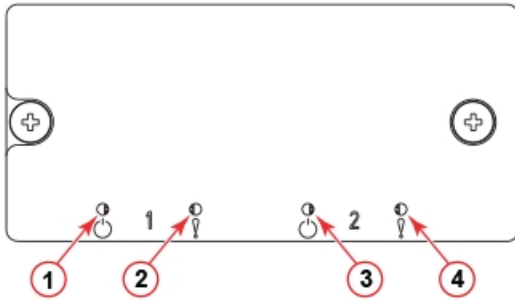



Figure 29. WWN card LEDs on bezel

- 1 - Power LED for WWN card 1
- 2 - Status LED for WWN card 1
- 3 - Power LED for WWN card 2
- 4 - Status LED for WWN card 2

Table 13. WWN card LED descriptions

LED purpose	Color	Status	Recommended action
Power 	No light (LED is off)	Card is not receiving power.	Ensure that device power supplies are firmly seated, power cables are connected, and that cables are connected to power source.
	Steady green	Card is receiving power.	No action required.
Status 	No light (LED is off)	Card is either healthy or does not have power.	No action required.
	Steady amber	Card is faulty	Replace card.

Interpreting power supply LEDs

Refer to the following illustration and table to interpret the LED patterns on the power supply. The LED patterns may temporarily change during POST and other diagnostic tests. The SAN512B-6 can have up to four power supplies.

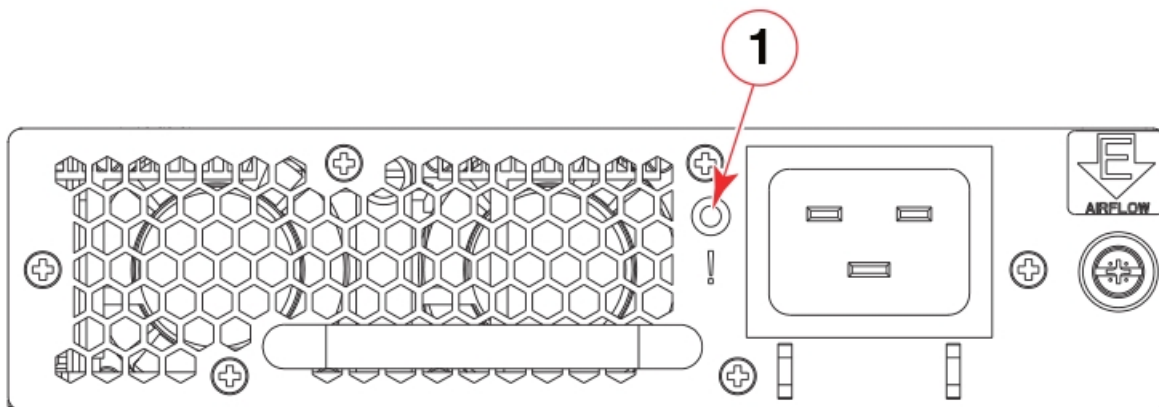

Figure 30. Power supply LED

- 1 - Power status LED

The following table describes the power supply LED patterns and the recommended actions for those patterns. In the unlikely event of a faulty power

supply, the status LED will flash in a coded pattern to provide additional fault information. Record the sequence of flashes and status as defined in the table to provide to your support representative along with **supportsave** output data.

Table 14. Power supply LED descriptions



LED purpose	Color	Status	Recommended action
Power status 	No light (LED is off)	Power supply does not have incoming power and is not providing power to the device. Note: When incoming power is first removed, LED flashes, and then turns off.	Ensure that the power supply is firmly seated, power cable is connected, and that power cable is connected to power source. Disconnect power cable from power supply, remove and reinsert power supply, and then reconnect power cable to restart. If status persists, replace power supply assembly.
	Steady green	Power supply has incoming power and is providing power to the device.	No action required.
	Flashing on once, and then off 5 seconds.	AC power disconnected.	Check power connection at power supply, cable, and AC power source. If all check out, disconnect power cable from power supply, remove and reinsert power supply, and then reconnect power cable to restart. If status persists, replace power supply assembly.
	Flashing on two times, and then off 5 seconds.	48V is out of range.	Disconnect power cable from power supply, remove and reinsert power supply, and then reconnect power cable to restart. If status persists, replace power supply assembly. If status persists, replace power supply.
	Flashing on three times, and then off 5 seconds.	12V is out of range.	Disconnect power cable from power supply, remove and reinsert power supply, and then reconnect power cable to restart. If status persists, replace power supply assembly.
	Flashing on four times, and then off 5 seconds.	AC input is under voltage.	Verify voltage in power distribution unit (PDU) or system providing power to power supply assembly. Check cabling and voltage between PDU and switch. Correct the voltage as necessary. If correct voltage is verified, replace power supply assembly.

Table 15. Power supply LED descriptions (continued)

LED purpose	Color	Status	Recommended action	
Power status 		Flashing on five times, and then off 5 seconds.	Power supply assembly fan is faulty.	Replace power supply.
		Flashing on six times, and then off 5 seconds.	Over temperature protection.	Check for blocked air flow or high ambient temperature at power supply. If status persists, replace power supply.
		Flashing on seven times, and then off 5 seconds.	Power supply is disabled.	Disconnect power cable from power supply, remove and reinsert power supply, and then reconnect power cable to restart. If status persists, replace power supply assembly. If status persists, replace power supply.

Note: If airflow direction for a power supply assembly does not match the chassis airflow direction as stored on WWN cards, the power supply will have a "fault" status. However, LED operation for the power supply will not indicate a fault.

Interpreting fan assembly LEDs

Refer to the following illustration and table to interpret the LED patterns on fan assemblies. The LED patterns may temporarily change during POST and other diagnostic tests. The SAN512B-6 has three fan assemblies.

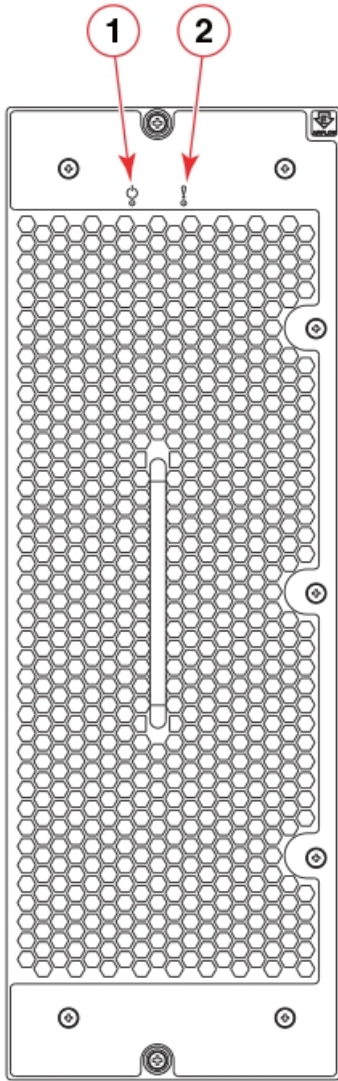

Figure 31. Fan assembly LEDs

1 - Power LED

2 - Status LED

Table 16. Fan assembly LED descriptions



LED purpose	Color	Status	Recommended action
Power 	No light (LED is off)	Fan assembly does not have power.	Ensure that the fan assembly is firmly seated and has power.
	Steady green	Fan assembly has power.	No action required.

Table 16. Fan assembly LED descriptions (continued)

LED purpose	Color	Status	Recommended action
Status 	No light (LED is off)	Fan assembly is either healthy or does not have power.	Ensure that the fan assembly has power.
	Steady amber	Fan assembly is being initialized or has a failure (full or partial).	Wait to see if fan fully initializes. If LED remains amber, replace the fan assembly.
	Slow-flashing amber (on 2 seconds, then off 2 seconds)	Fan assembly is not seated correctly or is faulty.	Pull the unit out and reseal it. If the LED continues to flash, replace the unit.
	Flashing amber (on ½ second, then off 3.5 seconds)	Fan is disabled.	Run the fanEnable command to enable the fan.
	Fast-flashing amber (on ½ second, then off ½ second)	Environmental range exceeded.	Check for out-of-bounds environmental condition, resolve any problems, and reseal the unit. If the LED continues to flash, replace the unit.

Note: If LED operation indicates fault or no power, verify that fan is fully seated in chassis and that captive screws securing fan in chassis are fully tightened. If screws are loose, blowback from fans may unseat fan from chassis connectors.

Interpreting POST and boot results

The device performs Power-On Self-Test (POST) by default each time the device is powered on, rebooted, or reset. The device can be rebooted using the **reboot** to reboot each CP individually) or **fastBoot** commands. The **fastBoot** command reboots the switches without running POST. If the active CP blade is rebooted, it fails over to the standby CP blade.

POST

About this task

The device automatically performs POST each time it is powered on or reset.

To verify that POST has completed without error, do the following:

- Verify that all LEDs return to a normal state after POST completes.

If one or more LEDs do not return to a normal state, and this is not due to the device being set to beacon, refer to the relevant LED table to identify and correct the problem. For port blades, and CP and core switch blades, the **slotShow** command can be used to check the status of the slots. For information about turning beaconing on or off, refer to the *Fabric OS Administrator's Guide*.
- Verify that the switch prompt displays when POST completes.

If it does not display, POST was not successfully completed. Contact the device supplier for support.
- Review the system error log using the **errShow** or **errDump** commands.

Any errors detected during POST are written to the system log, which is accessible through the **errShow** command. For information about error messages, refer to the *Fabric OS Message Reference*.

POST includes the following steps:

Procedure

1. Preliminary POST diagnostics are run.
2. Operating system is initialized.
3. Hardware is initialized.
4. Diagnostic tests are run on several functions, including circuitry, port functionality, ability to send and receive frames, all aspects of memory, parity, statistics counters, and serialization.

Boot

About this task

In addition to POST, boot includes the following steps after POST is complete:

Procedure

1. Universal port configuration is performed.
2. Links are initialized.
3. Fabric is analyzed. If any ports are connected to other switches, the device participates in a fabric configuration.
4. The device obtains a domain ID and assigns port addresses.
5. Unicast routing tables are constructed.
6. Normal port operation is enabled.

Using monitoring commands

This section provides example output and explanation for commands referenced in this guide for monitoring and verifying operation of the director and various components, such as blades, power supply assemblies, and fan assemblies.

Output for the following commands is provided:

- switchShow
- chassisShow
- haShow
- tempShow
- psShow
- sensorShow
- sfpShow
- fanShow
- errDump
- HistoryShow
- SupportSave

For more detail on using these commands, refer to the *Fabric OS Command Reference*. For more information on error messages, refer to the *Fabric OS Message Reference*.

chassisShow

The **chassisShow** can be especially helpful in monitoring the health of the device. This command provides information on installed blade, fan assembly, and power supply assembly FRUs. In addition, customer-supplied information can also be viewed, if included, for each FRU type. Four measurements to note are:

- Power Consume Factor: Maximum power allocated for a given FRU. Except for power supply assemblies, all power is shown as a negative number.
- Power Usage: If shown, this reflects real-time power usage for the FRU.
- Time Awake: Time that the system has been powered on since the last reboot.
- Time Alive: Reflects the total power-on time for the FRU (when available).

The following examples show output from this command.

Note: The output has been truncated to reduce duplicate information.

```
chassis:admin> chassisshow
Chassis Family:          SAN512B-6
Chassis Backplane Revision: 0

SW BLADE Slot: 3
Header Version:         2
Power Consume Factor:   -245W
Power Usage:            -152W
Factory Part Num:       60-1003325-01
Factory Serial Num:     DYJ0339L029
Manufacture:            Day: 6 Month: 11 Year: 2015
Update:                 Day: 15 Month: 2 Year: 2016
Time Alive:             26 days
Time Awake:             0 days
ID:

SW BLADE Slot: 4
Header Version:         2
Power Consume Factor:   -245W
Power Usage:            -157W
Factory Part Num:       60-1003325-01
Factory Serial Num:     DYJ0339L014
Manufacture:            Day: 3 Month: 10 Year: 2015
Update:                 Day: 15 Month: 3 Year: 2016
Time Alive:             80 days
Time Awake:             0 days
ID:

CP BLADE Slot: 1
Header Version:         2
Power Consume Factor:   -50W
Power Usage:            -47W
Factory Part Num:       60-1003201-09
Factory Serial Num:     DYK0338L008
Manufacture:            Day: 7 Month: 10 Year: 2015
Update:                 Day: 23 Month: 3 Year: 2016
Time Alive:             84 days
Time Awake:             0 days
ID:

CP BLADE Slot: 2
Header Version:         2
Power Consume Factor:   -50W
Power Usage:            -41W
Factory Part Num:       60-1003201-09
Factory Serial Num:     DYK0338L00E
Manufacture:            Day: 7 Month: 10 Year: 2015
Update:                 Day: 23 Month: 3 Year: 2016
```

Time Alive: 87 days
Time Awake: 0 days
ID:

SW BLADE Slot: 5
Header Version: 2
Power Consume Factor: -420W
Power Usage: -264W
Factory Part Num: 60-1003373-01
Factory Serial Num: EAL0339L009
Manufacture: Day: 24 Month: 10 Year: 2015
Update: Day: 12 Month: 3 Year: 2016
Time Alive: 66 days
Time Awake: 0 days
ID:

SW BLADE Slot: 6
Header Version: 2
Power Consume Factor: -420W
Power Usage: -286W
Factory Part Num: 60-1003373-01
Factory Serial Num: EAL0339L019
Manufacture: Day: 23 Month: 10 Year: 2015
Update: Day: 12 Month: 3 Year: 2016
Time Alive: 63 days
Time Awake: 0 days
ID:

CORE BLADE Slot: 7
Header Version: 2
Power Consume Factor: -450W
Power Usage: -264W
Factory Part Num: 60-1003199-08
Factory Serial Num: DYH0344L005
Manufacture: Day: 17 Month: 11 Year: 2015
Update: Day: 0 Month: 0 Year: 0
Time Alive: 0 days
Time Awake: 0 days
ID:

CORE BLADE Slot: 8
Header Version: 2
Power Consume Factor: -450W
Power Usage: -289W
Factory Part Num: 60-1003199-08
Factory Serial Num: DYH0344L003
Manufacture: Day: 7 Month: 11 Year: 2015
Update: Day: 0 Month: 0 Year: 0
Time Alive: 0 days
Time Awake: 0 days
ID:

SW BLADE Slot: 9
Header Version: 2
Power Consume Factor: -245W
Power Usage: -154W
Factory Part Num: 60-1003200-07
Factory Serial Num: DYJ0332L035
Manufacture: Day: 26 Month: 9 Year: 2015
Update: Day: 15 Month: 3 Year: 2016
Time Alive: 80 days
Time Awake: 0 days
ID:

SW BLADE Slot: 10

Header Version: 2
Power Consume Factor: -245W
Power Usage: -154W
Factory Part Num: 60-1003325-01
Factory Serial Num: DYJ0339L00J
Manufacture: Day: 4 Month: 10 Year: 2015
Update: Day: 12 Month: 3 Year: 2016
Time Alive: 78 days
Time Awake: 0 days
ID:

SW BLADE Slot: 11
Header Version: 2
Power Consume Factor: -245W
Power Usage: -154W
Factory Part Num: 60-1003325-01
Factory Serial Num: DYJ0339L00J
Manufacture: Day: 4 Month: 10 Year: 2015
Update: Day: 12 Month: 3 Year: 2016
Time Alive: 78 days
Time Awake: 0 days
ID:

SW BLADE Slot: 12
Header Version: 2
Power Consume Factor: -245W
Power Usage: -154W
Factory Part Num: 60-1003325-01
Factory Serial Num: DYJ0339L00J
Manufacture: Day: 4 Month: 10 Year: 2015
Update: Day: 12 Month: 3 Year: 2016
Time Alive: 78 days
Time Awake: 0 days
ID:

POWER SUPPLY Unit: 1
Power Source: AC
Fan Direction: Non-portside Intake
Header Version: 2
Power Consume Factor: 2870w
Factory Part Num: 23-0000161-01
Factory Serial Num: DUC2M35L092
Manufacture: Day: 25 Month: 8 Year: 2015
Update: Day: 15 Month: 2 Year: 2016
Time Alive: 57 days
Time Awake: 2 days
ID:

POWER SUPPLY Unit: 2
Power Source: AC
Fan Direction: Non-portside Intake
Header Version: 2
Power Consume Factor: 2870w
Factory Part Num: 23-0000161-01
Factory Serial Num: DUC2M33L06V
Manufacture: Day: 10 Month: 8 Year: 2015
Update: Day: 15 Month: 2 Year: 2016
Time Alive: 68 days
Time Awake: 2 days
ID:

FAN Unit: 1
Fan Direction: Non-portside Intake
Header Version: 2
Power Consume Factor: -300w
Factory Part Num: 60-1003203-03
Factory Serial Num: DYL0329L04R

Manufacture: Day: 3 Month: 10 Year: 15
Update: Day: 15 Month: 2 Year: 2016
Time Alive: 68 days
Time Awake: 2 days
ID:

FAN Unit: 2
Fan Direction: Non-portside Intake
Header Version: 2
Power Consume Factor: -300w
Factory Part Num: 60-1003203-03
Factory Serial Num: DYL0329L02E
Manufacture: Day: 10 Month: 10 Year: 15
Update: Day: 15 Month: 2 Year: 2016
Time Alive: 68 days
Time Awake: 2 days
ID:

FAN Unit: 3
Fan Direction: Non-portside Intake
Header Version: 2
Power Consume Factor: -300w
Factory Part Num: 60-1003203-03
Factory Serial Num: DYL0329L055
Manufacture: Day: 10 Month: 10 Year: 15
Update: Day: 15 Month: 2 Year: 2016
Time Alive: 68 days
Time Awake: 2 days
ID:

WVN Unit: 1
System AirFlow: Non-portside Intake
Header Version: 2
Power Consume Factor: -1W
Factory Part Num: 60-1003194-02
Factory Serial Num: DZH0331L039
Manufacture: Day: 3 Month: 10 Year: 15
Update: Day: 0 Month: 0 Year: 0
Time Alive: 24 days
Time Awake: 0 days
ID: ***(@*%)(*
Part Num: ***(@*%)(*@#%(@*%)@*
Serial Num: ***(@*%)(*@#%(@*%)@*
Revision Num: ***(
ID:

WVN Unit: 2
System AirFlow: Non-portside Intake
Header Version: 2
Power Consume Factor: -1W
Factory Part Num: 60-1003194-02
Factory Serial Num: DZH0331L032
Manufacture: Day: 3 Month: 10 Year: 15
Update: Day: 0 Month: 0 Year: 0
Time Alive: 24 days
Time Awake: 0 days
ID: ***(@*%)(*
Part Num: ***(@*%)(*@#%(@*%)@*
Serial Num: ***(@*%)(*@#%(@*%)@*
Revision Num: ***(
ID:

Chassis Factory Serial Num: BAF0289K00H

errDump and errShow

Use the **errShow** command to display device error log messages one at a time. Use the **errDump** command to display error log messages without any page breaks. The

output of these commands are unique for each Control Processor (CP), so must be executed on each CP blade to obtain a complete record.

Following is a partial example of **errDump** output.

```
chassis:admin> errdump
2016/03/28-08:44:28,[FV-1001], 90, SLOT 1 CHASSIS,INFO,My_Switch,Flow Vision daemon initialized.
2016/03/28-08:44:51,[FSSM-1002],91,SLOT 1 CHASSIS,INFO,My_Chassis,HA State is in sync.
2016/03/28-08:44:51,[SULB-1003],92,SLOT 1 CHASSIS,INFO,My_Chassis,Firmwarecommit has started.
2016/03/28-08:48:27,[SULB-1004],93,SLOT 1 CHASSIS,INFO,My_Chassis,Firmwarecommit has completed.
2016/03/28-08:48:27,[SULB-1036],94,SLOT 1 CHASSIS,INFO,My_Chassis,The new Version: Fabric OS v8.0.1_b1d52.
2016/03/28-08:48:27,[SULB-1002],95,SLOT 1 CHASSIS,INFO,My_Chassis,Firmwaredownload command completed successfully.
2016/03/28-08:50:51,[IPAD-1003],96,SLOT 1 CHASSIS,INFO,My_Chassis,DNS parameters saved successfully.
-----
```

Note the following about this output:

- The output can contain several thousand lines. Use **errClear** command to reset the output when needed. This command clears all error log messages for all director instances on the CP where the command is issued.
- *My_Switch* corresponds to what is entered for switchname and is a switch or logical switch event.
- *My_Chassis* corresponds to what is entered for chassisname and is a chassis event.

fanShow

Use this command to display the current status and speed of each installed fan. The following is an example of **fanShow** output.

```
chassis:admin> fanshow
Fan 1 is Ok, speed is 6993 RPM
Fan 2 is Ok, speed is 6993 RPM
```

haShow

Use this command to display the control processor (CP) status. The display includes the following information:

- Local CP state (slot number and CP ID), warm or cold, recovering or recovered.
- Remote CP state (slot number and CP ID).
- High Availability (enabled or disabled).
- Heartbeat (up or down).
- Health of standby CP.
- HA synchronization status.

The following is an example of **haShow** output.

```
chassis:admin> hashow
Local CP (Slot 1, CP0): Active, Warm Recovered
Remote CP (Slot 2, CP1): Standby, Healthy
HA enabled, Heartbeat Up, HA State synchronized
```

Note the following about this output:

- A warm recovery typically does not disrupt traffic flow.
- A cold recovery is usually a result of a reboot of the active CP, which disrupts traffic.

- A lack of HA synchronization can be related to a firmware download in progress or that the device is recovering from a reboot or power-cycle.

historyShow

Use this command to display the entire history log, which includes insertion and removal events for field-replaceable units (FRUs), such as blades, power supplies, fans, and world wide name (WWN) cards.

The following is an example of **historyShow** output.

```
chassis:admin> historyshow
```

```
CORE BLADE Slot 5      Inserted at Fri Jun 17 12:05:02 2016
Factory Part Number:  60-1003324-01
Factory Serial Number: DZD0331L004

POWER SUPPLY Unit 1    Inserted at Fri Jun 17 12:05:26 2016
Factory Part Number:  23-0000162-01
Factory Serial Number: DUD2M36L04N

POWER SUPPLY Unit 2    Inserted at Fri Jun 17 12:05:26 2016
Factory Part Number:  23-0000162-01
Factory Serial Number: DUD2M08M08G

CORE BLADE Slot 6      Inserted at Fri Jun 17 12:05:26 2016
Factory Part Number:  60-1003324-01
Factory Serial Number: DZD0331L016

FAN Unit 1             Inserted at Fri Jun 17 12:05:27 2016
Factory Part Number:  60-1003203-03
Factory Serial Number: DYL0329L05R

FAN Unit 2             Inserted at Fri Jun 17 12:05:27 2016
Factory Part Number:  60-1003203-03
Factory Serial Number: DYL0329L01Z

SW BLADE Slot 3        Inserted at Fri Jun 17 12:05:27 2016
Factory Part Number:  60-1003200-07
Factory Serial Number: DYJ0332L00H

WWN Unit 1             Inserted at Fri Jun 17 12:05:27 2016
Factory Part Number:  60-1003194-02
Factory Serial Number: DZH0331L00E

WWN Unit 2             Inserted at Fri Jun 17 12:05:28 2016
Factory Part Number:  60-1003194-02
Factory Serial Number: DZH0331L01C

SW BLADE Slot 4        Inserted at Fri Jun 17 12:05:28 2016
Factory Part Number:  60-1003336-01
Factory Serial Number: EAL0338L00R

SW BLADE Slot 7        Inserted at Fri Jun 17 12:05:29 2016
Factory Part Number:  60-1003200-07
Factory Serial Number: DYJ0332L02G

SW BLADE Slot 8        Inserted at Fri Jun 17 12:05:29 2016
Factory Part Number:  60-1003200-07
Factory Serial Number: DYJ0332L03G

CP BLADE Slot 1        Inserted at Fri Jun 17 12:05:30 2016
Factory Part Number:  60-1003201-09
Factory Serial Number: DYK0331L007
```

CP BLADE Slot 2 Inserted at Fri Jun 17 12:05:31 2016
Factory Part Number: 60-1003201-09
Factory Serial Number: DYK0331L00N

psShow

Use this command to display the current status of installed power supplies. The following is an example of **psShow** output.

```
chassisX6-8:admin> psshow
Power Supply #1 is OK
V10M03, DUE2M03M04P ,23-0000163-01,21,DELTA,ECD16020044 ,S1,DUE2M03M
Power Supply #2 is OK
V10L35, DUC2M35L0CL ,23-0000161-01,31,DELTA,ECD16020042 ,S5,DUC2M35L
Power Supply #3 is OK
V10L41, DUC2M41L0JJ ,23-0000161-01,32,DELTA,ECD16020042 ,S6,DUC2M41L
Power Supply #4 is OK
V10M03, DUE2M03M04S ,23-0000163-01,21,DELTA,ECD16020044 ,S1,DUE2M03M
```

sensorShow

Use this command to display the current temperature, fan, and power supply status, and readings from sensors located on the device. The **sensorShow** command output is similar to **tempShow** except that fan and power supply sensor information is also included. Temperatures are in Celsius only.

The following is an example of **sensorShow** output.

```
chassis:admin> sensorshow
sensor 1: (Temperature) is Ok, value is 29 C
sensor 2: (Temperature) is Ok, value is 47 C
sensor 3: (Temperature) is Ok, value is 43 C
sensor 4: (Temperature) is Ok, value is 34 C
sensor 5: (Temperature) is Ok, value is 53 C
sensor 6: (Temperature) is Ok, value is 36 C
sensor 7: (Temperature) is Ok, value is 39 C
sensor 8: (Temperature) is Ok, value is 33 C
sensor 9: (Temperature) is Ok, value is 41 C
sensor 10: (Temperature) is Ok, value is 43 C
sensor 11: (Temperature) is Ok, value is 44 C
sensor 12: (Temperature) is Ok, value is 41 C
sensor 13: (Temperature) is Ok, value is 45 C
sensor 14: (Temperature) is Ok, value is 31 C
sensor 15: (Temperature) is Ok, value is 45 C
sensor 16: (Temperature) is Ok, value is 48 C
sensor 17: (Temperature) is Ok, value is 31 C
sensor 18: (Temperature) is Ok, value is 45 C
sensor 19: (Temperature) is Ok, value is 45 C
sensor 20: (Temperature) is Ok, value is 29 C
sensor 21: (Temperature) is Ok, value is 44 C
sensor 22: (Temperature) is Ok, value is 43 C
sensor 23: (Temperature) is Ok, value is 30 C
sensor 24: (Temperature) is Ok, value is 45 C
sensor 25: (Temperature) is Ok, value is 42 C
sensor 26: (Fan           ) is Ok,speed is 6984 RPM
sensor 27: (Fan           ) is Ok,speed is 6984 RPM
sensor 28: (Power Supply) is Ok
sensor 29: (Power Supply) is Ok
```

slotShow

Use this command to display the current status of each blade in the system. Depending on the option used, the command retrieves information on blade type, blade ID, status, IBM model name, and power usage for each slot in the switch or chassis. Use the **-m** operand to display the blade model name and status.

Following is an example of **slotShow** output.

Note: The most common status is shown. A status of Faulty (51) would display for a POST failure during power-on or a blade hot-plug.

```
chassis:admin> slotShow -m
Slot  Blade Type      ID   Model Name      Status
-----
  1    CP BLADE      175   CPX6             ENABLED
  2    CP BLADE      175   CPX6             ENABLED
  3    SW BLADE      178   FC32-48          ENABLED
  4    SW BLADE      178   FC32-48          ENABLED
  5    AP BLADE      186   SX6              ENABLED
  6    SW BLADE      178   FC32-48          DISABLED
  7    CORE BLADE    176   CR32-8           ENABLED
  8    CORE BLADE    176   CR32-8           ENABLED
  9    SW BLADE      178   FC32-48          ENABLED
 10    UNKNOWN
 11    SW BLADE      178   FC32-48          ENABLED
 12    SW BLADE      178   FC32-48          ENABLED
switch:admin>
```

sfpShow

Use this command without operands to display a summary of all installed SFPs. For each port, the command displays the SFP type and, for serial ID SFP, the vendor name and SFP, serial number, and speed capability (in Gbps). Use this command with a port number to display detailed information about the serial ID SFP in the specified port.

Following is example of **sfpShow** output.

```
chassis:admin> sfpshow
Slot 3/Port 0: --
Slot 3/Port 1: --
Slot 3/Port 2: --
Slot 3/Port 3: --
Slot 3/Port 4: --
Slot 3/Port 5: --
Slot 3/Port 6: --
Slot 3/Port 7: --
Slot 3/Port 8: --
Slot 3/Port 9: --
Slot 3/Port 10: --
Slot 3/Port 11: --
Slot 3/Port 12: --
Slot 3/Port 13: --
Slot 3/Port 14: --
Slot 3/Port 15: --
Slot 4/Port 0: --
Slot 4/Port 1: --
Slot 4/Port 2: --
Slot 4/Port 3: --
Slot 4/Port 4: --
Slot 4/Port 5: --
Slot 4/Port 6: --
Slot 4/Port 7: --
Slot 4/Port 8: --
Slot 4/Port 9: --
Slot 4/Port 10: --
Slot 4/Port 11: --
Slot 4/Port 12: --
Slot 4/Port 13: --
Slot 4/Port 14: --
Slot 4/Port 15: --
Slot 5/Port 0: --
Slot 5/Port 1: --
Slot 5/Port 2: --
Slot 5/Port 3: --
Slot 5/Port 4: --
Slot 5/Port 5: --
Slot 5/Port 6: --
```

Slot 5/Port 7: --
Slot 5/Port 8: --
Slot 5/Port 9: --
Slot 5/Port 10: --
Slot 5/Port 11: --
Slot 5/Port 12: --
Slot 5/Port 13: --
Slot 5/Port 14: --
Slot 5/Port 15: --
Slot 6/Port 0: --
Slot 6/Port 1: --
Slot 6/Port 2: --
Slot 6/Port 3: --
Slot 6/Port 4: --
Slot 6/Port 5: --
Slot 6/Port 6: --
Slot 6/Port 7: --
Slot 6/Port 8: --
Slot 6/Port 9: --
Slot 6/Port 10: --
Slot 6/Port 11: --
Slot 6/Port 12: --
Slot 6/Port 13: --
Slot 6/Port 14: --
Slot 6/Port 15: --
Slot 9/Port 0: --
Slot 9/Port 1: --
Slot 9/Port 2: --
Slot 9/Port 3: --
Slot 9/Port 4: --
Slot 9/Port 5: --
Slot 9/Port 6: --
Slot 9/Port 7: --
Slot 9/Port 8: --
Slot 9/Port 9: --
Slot 9/Port 10: --
Slot 9/Port 11: --
Slot 9/Port 12: --
Slot 9/Port 13: --
Slot 9/Port 14: --
Slot 9/Port 15: --
Slot 10/Port 0: --
Slot 10/Port 1: --
Slot 10/Port 2: --
Slot 10/Port 3: --
Slot 10/Port 4: --
Slot 10/Port 5: --
Slot 10/Port 6: --
Slot 10/Port 7: --
Slot 10/Port 8: --
Slot 10/Port 9: --
Slot 10/Port 10: --
Slot 10/Port 11: --
Slot 10/Port 12: --
Slot 10/Port 13: --
Slot 10/Port 14: --
Slot 10/Port 15: --
Slot 11/Port 0: --
Slot 11/Port 1: --
Slot 11/Port 2: --
Slot 11/Port 3: --
Slot 11/Port 4: --
Slot 11/Port 5: --
Slot 11/Port 6: --
Slot 11/Port 7: --
Slot 11/Port 8: --
Slot 11/Port 9: --
Slot 11/Port 10: --
Slot 11/Port 11: --
Slot 11/Port 12: --
Slot 11/Port 13: --
Slot 11/Port 14: --
Slot 11/Port 15: --
Slot 12/Port 0: --
Slot 12/Port 1: --
Slot 12/Port 2: --
Slot 12/Port 3: --
Slot 12/Port 4: --
Slot 12/Port 5: --
Slot 12/Port 6: --

Slot 12/Port 7: --
Slot 12/Port 8: --
Slot 12/Port 9: --
Slot 12/Port 10: --
Slot 12/Port 11: --
Slot 12/Port 12: --
Slot 12/Port 13: --
Slot 12/Port 14: --
Slot 12/Port 15: --
Slot 5/Port 16: --
Slot 5/Port 17: --
Slot 5/Port 18: --
Slot 5/Port 19: --
Slot 5/Port 20: --
Slot 5/Port 21: --
Slot 5/Port 22: --
Slot 5/Port 23: --
Slot 5/Port 24: --
Slot 5/Port 25: --
Slot 5/Port 26: --
Slot 5/Port 27: --
Slot 5/Port 28: --
Slot 5/Port 29: --
Slot 5/Port 30: --
Slot 5/Port 31: --
Slot 6/Port 16: --
Slot 6/Port 17: --
Slot 6/Port 18: --
Slot 6/Port 19: --
Slot 6/Port 20: --
Slot 6/Port 21: --
Slot 6/Port 22: --
Slot 6/Port 23: --
Slot 6/Port 24: --
Slot 6/Port 25: --
Slot 6/Port 26: --
Slot 6/Port 27: --
Slot 6/Port 28: --
Slot 6/Port 29: --
Slot 6/Port 30: --
Slot 6/Port 31: --
Slot 10/Port 16: --
Slot 10/Port 17: --
Slot 10/Port 18: --
Slot 10/Port 19: --
Slot 10/Port 20: --
Slot 10/Port 21: --
Slot 10/Port 22: --
Slot 10/Port 23: --
Slot 10/Port 24: --
Slot 10/Port 25: --
Slot 10/Port 26: --
Slot 10/Port 27: --
Slot 10/Port 28: --
Slot 10/Port 29: --
Slot 10/Port 30: --
Slot 10/Port 31: --
Slot 11/Port 16: --
Slot 11/Port 17: --
Slot 11/Port 18: --
Slot 11/Port 19: --
Slot 11/Port 20: --
Slot 11/Port 21: --
Slot 11/Port 22: --
Slot 11/Port 23: --
Slot 11/Port 24: --
Slot 11/Port 25: --
Slot 11/Port 26: --
Slot 11/Port 27: --
Slot 11/Port 28: --
Slot 11/Port 29: --
Slot 11/Port 30: --
Slot 11/Port 31: --
Slot 12/Port 16: --
Slot 12/Port 17: --
Slot 12/Port 18: --
Slot 12/Port 19: --
Slot 12/Port 20: --
Slot 12/Port 21: --
Slot 12/Port 22: --

```

Slot 12/Port 23: --
Slot 12/Port 24: --
Slot 12/Port 25: --
Slot 12/Port 26: --
Slot 12/Port 27: --
Slot 12/Port 28: --
Slot 12/Port 29: --
Slot 12/Port 30: --
Slot 12/Port 31: --
Slot 5/Port 32: --
Slot 5/Port 33: --
Slot 5/Port 34: --
Slot 5/Port 35: --
Slot 5/Port 36: --
Slot 5/Port 37: --
Slot 5/Port 38: --
Slot 5/Port 39: --
Slot 5/Port 40: --
Slot 5/Port 41: --
Slot 5/Port 42: --
Slot 5/Port 43: --
Slot 5/Port 44: --
Slot 5/Port 45: --
Slot 5/Port 46: --
Slot 5/Port 47: --
Slot 6/Port 32: id (sw) Vendor: BROCADE Serial No: JAF315420000114 Speed: 8,16,32_Gbps
Slot 6/Port 33: id (sw) Vendor: BROCADE Serial No: JAF315410000NDL Speed: 8,16,32_Gbps
Slot 6/Port 34: id (sw) Vendor: BROCADE Serial No: JAF31542000010P Speed: 8,16,32_Gbps
Slot 6/Port 35: id (sw) Vendor: BROCADE Serial No: JAF315410000NNZ Speed: 8,16,32_Gbps
Slot 6/Port 36: --
Slot 6/Port 37: --
Slot 6/Port 38: --
Slot 6/Port 39: --
Slot 6/Port 40: id (sw) Vendor: BROCADE Serial No: HAA1121210791A2 Speed: 4,8,16_Gbps
Slot 6/Port 41: id (sw) Vendor: BROCADE Serial No: HAF112150000W4H Speed: 4,8,16_Gbps
Slot 6/Port 42: id (sw) Vendor: BROCADE Serial No: HAF110530000GN1 Speed: 4,8,16_Gbps
Slot 6/Port 43: id (sw) Vendor: BROCADE Serial No: HAF110530000GN4 Speed: 4,8,16_Gbps
Slot 6/Port 44: --
Slot 6/Port 45: --
Slot 6/Port 46: --
Slot 6/Port 47: --
Slot 10/Port 32: --
Slot 10/Port 33: --
Slot 10/Port 34: --
Slot 10/Port 35: --
Slot 10/Port 36: --
Slot 10/Port 37: --
Slot 10/Port 38: --
Slot 10/Port 39: --
Slot 10/Port 40: id (sw) Vendor: BROCADE Serial No: HAA21505108WZH2 Speed: 4,8,16_Gbps
Slot 10/Port 41: --
Slot 10/Port 42: --
Slot 10/Port 43: --
Slot 10/Port 44: --
Slot 10/Port 45: --
Slot 10/Port 46: --
Slot 10/Port 47: --
Slot 11/Port 32: --
Slot 11/Port 33: --
Slot 11/Port 34: --
Slot 11/Port 35: --
Slot 11/Port 36: --
Slot 11/Port 37: --
Slot 11/Port 38: --
Slot 11/Port 39: --
Slot 11/Port 40: --
Slot 11/Port 41: --
Slot 11/Port 42: --
Slot 11/Port 43: --
Slot 11/Port 44: --
Slot 11/Port 45: --
Slot 11/Port 46: --
Slot 11/Port 47: --
Slot 12/Port 32: --
Slot 12/Port 33: --
Slot 12/Port 34: --
Slot 12/Port 35: --
Slot 12/Port 36: --
Slot 12/Port 37: --
Slot 12/Port 38: --

```

Slot 12/Port 39: --
Slot 12/Port 40: --
Slot 12/Port 41: --
Slot 12/Port 42: --
Slot 12/Port 43: --
Slot 12/Port 44: --
Slot 12/Port 45: --
Slot 12/Port 46: --
Slot 12/Port 47: --
Slot 7/Port 0: --
Slot 7/Port 1: --
Slot 7/Port 2: --
Slot 7/Port 3: --
Slot 7/Port 4: --
Slot 7/Port 5: --
Slot 7/Port 6: --
Slot 7/Port 7: --
Slot 7/Port 8: --
Slot 7/Port 9: --
Slot 7/Port 10: --
Slot 7/Port 11: --
Slot 7/Port 12: --
Slot 7/Port 13: --
Slot 7/Port 14: --
Slot 7/Port 15: --
Slot 7/Port 16: --
Slot 7/Port 17: --
Slot 7/Port 18: --
Slot 7/Port 19: --
Slot 7/Port 20: --
Slot 7/Port 21: --
Slot 7/Port 22: --
Slot 7/Port 23: --
Slot 7/Port 24: --
Slot 7/Port 25: --
Slot 7/Port 26: --
Slot 7/Port 27: --
Slot 7/Port 28: --
Slot 7/Port 29: --
Slot 7/Port 30: --
Slot 7/Port 31: --
Slot 8/Port 0: --
Slot 8/Port 1: --
Slot 8/Port 2: --
Slot 8/Port 3: --
Slot 8/Port 4: --
Slot 8/Port 5: --
Slot 8/Port 6: --
Slot 8/Port 7: --
Slot 8/Port 8: --
Slot 8/Port 9: --
Slot 8/Port 10: --
Slot 8/Port 11: --
Slot 8/Port 12: --
Slot 8/Port 13: --
Slot 8/Port 14: --
Slot 8/Port 15: --
Slot 8/Port 16: --
Slot 8/Port 17: --
Slot 8/Port 18: --
Slot 8/Port 19: --
Slot 8/Port 20: --
Slot 8/Port 21: --
Slot 8/Port 22: --
Slot 8/Port 23: --
Slot 8/Port 24: --
Slot 8/Port 25: --
Slot 8/Port 26: --
Slot 8/Port 27: --
Slot 8/Port 28: --
Slot 8/Port 29: --
Slot 8/Port 30: --
Slot 8/Port 31: --
Slot 7/Port 32: --
Slot 7/Port 33: --
Slot 7/Port 34: --
Slot 7/Port 35: --
Slot 7/Port 36: --
Slot 7/Port 37: --
Slot 7/Port 38: --

```

Slot 7/Port 39: --
Slot 7/Port 40: --
Slot 7/Port 41: --
Slot 7/Port 42: --
Slot 7/Port 43: --
Slot 7/Port 44: --
Slot 7/Port 45: --
Slot 7/Port 46: --
Slot 7/Port 47: --
Slot 7/Port 48: --
Slot 7/Port 49: --
Slot 7/Port 50: --
Slot 7/Port 51: --
Slot 7/Port 52: --
Slot 7/Port 53: --
Slot 7/Port 54: --
Slot 7/Port 55: --
Slot 7/Port 56: --
Slot 7/Port 57: --
Slot 7/Port 58: --
Slot 7/Port 59: --
Slot 7/Port 60: id 15/0 (id) Vendor: FINISAR CORP Serial No: DU8000J Speed:
Slot 7/Port 61: id 15/1 (id) Vendor: FINISAR CORP Serial No: DU8000J Speed:
Slot 7/Port 62: id 15/2 (id) Vendor: FINISAR CORP Serial No: DU8000J Speed:
Slot 7/Port 63: id 15/3 (id) Vendor: FINISAR CORP Serial No: DU8000J Speed:
Slot 8/Port 32: id 8/0 (sw) Vendor: BROCADE Serial No: ZTA11539000007E Speed: 32_Gbps
Slot 8/Port 33: id 8/1 (sw) Vendor: BROCADE Serial No: ZTA11539000007E Speed: 32_Gbps
Slot 8/Port 34: id 8/2 (sw) Vendor: BROCADE Serial No: ZTA11539000007E Speed: 32_Gbps
Slot 8/Port 35: id 8/3 (sw) Vendor: BROCADE Serial No: ZTA11539000007E Speed: 32_Gbps
Slot 8/Port 36: --
Slot 8/Port 37: --
Slot 8/Port 38: --
Slot 8/Port 39: --
Slot 8/Port 40: --
Slot 8/Port 41: --
Slot 8/Port 42: --
Slot 8/Port 43: --
Slot 8/Port 44: --
Slot 8/Port 45: --
Slot 8/Port 46: --
Slot 8/Port 47: --
Slot 8/Port 48: --
Slot 8/Port 49: --
Slot 8/Port 50: --
Slot 8/Port 51: --
Slot 8/Port 52: --
Slot 8/Port 53: --
Slot 8/Port 54: --
Slot 8/Port 55: --
Slot 8/Port 56: --
Slot 8/Port 57: --
Slot 8/Port 58: --
Slot 8/Port 59: --
Slot 8/Port 60: id 15/0 (sw) Vendor: BROCADE Serial No: ZTA11539000006R Speed: 32_Gbps
Slot 8/Port 61: id 15/1 (sw) Vendor: BROCADE Serial No: ZTA11539000006R Speed: 32_Gbps
Slot 8/Port 62: id 15/2 (sw) Vendor: BROCADE Serial No: ZTA11539000006R Speed: 32_Gbps
Slot 8/Port 63: id 15/3 (sw) Vendor: BROCADE Serial No: ZTA11539000006R Speed: 32_Gbps
GE: Slot 3/Port 0: --
GE: Slot 3/Port 1: --
GE: Slot 3/Port 2: --
GE: Slot 3/Port 3: --
GE: Slot 3/Port 4: --
GE: Slot 3/Port 5: --
GE: Slot 3/Port 6: --
GE: Slot 3/Port 7: --
GE: Slot 3/Port 8: --
GE: Slot 3/Port 9: --
GE: Slot 3/Port 10: --
GE: Slot 3/Port 11: --
GE: Slot 3/Port 12: --
GE: Slot 3/Port 13: --
GE: Slot 3/Port 14: --
GE: Slot 3/Port 15: --
GE: Slot 3/Port 16: --
GE: Slot 3/Port 17: --
GE: Slot 4/Port 0: --
GE: Slot 4/Port 1: --
GE: Slot 4/Port 2: --
GE: Slot 4/Port 3: --
GE: Slot 4/Port 4: --

```

```

GE: Slot 4/Port 5: --
GE: Slot 4/Port 6: --
GE: Slot 4/Port 7: --
GE: Slot 4/Port 8: --
GE: Slot 4/Port 9: --
GE: Slot 4/Port 10: --
GE: Slot 4/Port 11: --
GE: Slot 4/Port 12: --
GE: Slot 4/Port 13: --
GE: Slot 4/Port 14: --
GE: Slot 4/Port 15: --
GE: Slot 4/Port 16: --
GE: Slot 4/Port 17: --
GE: Slot 9/Port 0: --
GE: Slot 9/Port 1: --
GE: Slot 9/Port 2: --
GE: Slot 9/Port 3: --
GE: Slot 9/Port 4: --
GE: Slot 9/Port 5: --
GE: Slot 9/Port 6: --
GE: Slot 9/Port 7: --
GE: Slot 9/Port 8: --
GE: Slot 9/Port 9: --
GE: Slot 9/Port 10: --
GE: Slot 9/Port 11: --
GE: Slot 9/Port 12: --
GE: Slot 9/Port 13: --
GE: Slot 9/Port 14: --
GE: Slot 9/Port 15: --
GE: Slot 9/Port 16: --
GE: Slot 9/Port 17: --

```

switchShow

The **switchShow** command can be especially helpful in monitoring the health of the device. This command displays status, identification, and configuration information on the chassis and installed blades and ports. The following example shows output from this command.

Note: The following output has been truncated to reduce duplicate information.

```

chassisSAN512B-6:admin> switchshow
switchshow> switchshow
switchName: switch1_SW
switchType: 166.0
switchState: Online
switchMode: Native
switchRole: Subordinate
switchDomain: 1
switchId: fffc01
switchWwn: 10:00:00:25:f8:f1:15:80
zoning: ON (MPR4k)
switchBeacon: OFF
FC Router: OFF
FC Router BB Fabric ID: 128
Address Mode: 0
Fabric Name: BB1
HIF Mode: OFF

```

Index	Slot	Port	Address	Media	Speed	State	Proto
0	3	0	010000	id	N32	Online	FC F-Port 86:0d:00:11:0d:06:00:00
1	3	1	010100	id	N32	Online	FC F-Port 86:24:00:11:0d:07:00:00
2	3	2	010200	id	N32	Online	FC F-Port 86:0c:00:11:0d:05:00:00
3	3	3	010300	id	N32	Online	FC F-Port 86:25:00:11:0d:08:00:00
4	3	4	010400	id	N32	Online	FC F-Port 21:00:00:24:ff:90:55:30
5	3	5	010500	id	N32	Online	FC F-Port 21:00:00:24:ff:90:55:31
6	3	6	010600	id	N32	Online	FC F-Port 21:00:00:24:ff:90:55:9e
7	3	7	010700	id	N32	Online	FC F-Port 21:00:00:24:ff:90:55:9f
8	3	8	010800	id	N32	Online	FC E-Port 10:00:00:27:f8:f2:c8:b8
9	3	9	010900	id	N32	Online	FC E-Port 10:00:00:27:f8:f2:c6:b8 "ras010" (Trunk master)
10	3	10	010a00	id	N32	Online	FC E-Port 10:00:00:27:f8:f2:c7:b8 "ras010" (Trunk master)
11	3	11	010b00	id	N32	Online	FC E-Port 10:00:00:27:f8:f2:c8:b8 "ras010" (Trunk master)
12	3	12	010c00	--	N32	No_Module	FC
13	3	13	010d00	--	N32	No_Module	FC
14	3	14	010e00	--	N32	No_Module	FC
15	3	15	010f00	--	N32	No_Module	FC
128	3	16	018000	--	N32	No_Module	FC
129	3	17	018100	--	N32	No_Module	FC
130	3	18	018200	id	N32	Online	FC E-Port 10:00:50:eb:1a:f6:6c:68 "ras006" (Trunk master)
131	3	19	018300	id	N32	Online	FC E-Port 10:00:51:ee:1a:f6:6c:68 "ras006" (Trunk master)

-----output truncated -----

supportSave

Use this command to collect RASLOG, TRACE, supportShow, core file, FFDC data and other support information to a remote FTP location. On platforms that support a USB, the information can also be stored on an attached USB device. SupportShow information is available on Active and Standby CPs.

Following is an example of **supportSave** output. This output assumes that the **supportFtp** was used to set up FTP parameters (always recommended). In the following examples, the -c operand allows use of the FTP, SCP, or SFTP parameters set by **supportFtp**. The -n operand turns off confirmation prompting.

```
chassis:admin> supportsave -n -c

Saving support information for switch:ras010, module:RAS...
.....

Saving support information for switch:ras010, module:FTRACE_START...
....
Saving support information for switch:ras010, module:SSHOW_SYS...
.....

Saving support information for switch:ras010, module:SSHOW_ISWITCH...
.....

Saving support information for switch:ras010, module:FABRIC...
.....

Saving support information for switch:ras010, module:DIAG...
.....

Saving support information for switch:ras010, module:RTE...
Saving support information for switch:ras010, module:IF_TREE...
Saving support information for switch:ras010, module:ISCSID_DBG...
Saving support information for switch:ras010, module:AGDUMP...
Saving support information for switch:ras010, module:AGWWS...
Saving support information for switch:ras010, module:AGWVN_CFG...
Saving support information for switch:ras010, module:VPWVN_CFG...
....

Saving support information for switch:ras010, module:SSHOW_PLOG...
..

Saving support information for switch:ras010, module:SSHOW_OS...
.....

Saving support information for switch:ras010, module:SSHOW_EX...
..

Saving support information for switch:ras010, module:SSHOW_FABRIC...
.....

Saving support information for switch:ras010, module:SSHOW_SERVICE...
.....

Saving support information for switch:ras010, module:SSHOW_SEC...
.....

Saving support information for switch:ras010, module:SSHOW_NET...
.....

Saving support information for switch:ras010, module:SSHOW_FICON...
.....

Saving support information for switch:ras010, module:SSHOW_ASICDB...
```



```

.....
Saving support information for switch:ras010, module:SSHOW_AG...

Saving support information for switch:ras010, module:SSHOW_Cryp...

Saving support information for switch:ras010, module:SSHOW_FCIP...
.....
slot 4-dp1 support file transfer done.
.....
slot 4-dp0 support file transfer done.
.....

Saving support information for switch:ras010, module:SSHOW_PORT...
.
.
.

Saving support information for switch:ras010, module:SSHOW_DCEHSL...

Saving support information for switch:ras010, module:SSHOW_FLOW...
...

Saving support information for switch:ras010, module:CEEDEBUG...
Saving support information for switch:ras010, module:CEETECHSUPPORT...
Saving support information for switch:ras010, module:FCOESUPPORT...
Saving support information for switch:ras010, module:C2REGDUMP...
Saving support information for switch:ras010, module:C1REGDUMP...
Saving support information for switch:ras010, module:PBREGDUMP...
Saving support information for switch:ras010, module:BLSREGDUMP...
Saving support information for switch:ras010, module:AVREGDUMP...
Saving support information for switch:ras010, module:C3REGDUMP...
Saving support information for switch:ras010, module:C4REGDUMP...
Saving support information for switch:ras010, module:BCM_STATS...
Saving support information for switch:ras010, module:CRYP...

Saving support information for switch:ras010, module:FCIP...

Saving support information for switch:ras010, module:FCIP_DPLOGS...
.....

Saving support information for switch:ras010, module:VFABRIC...
.....

Saving support information for switch:ras010, module:MAPS...
Saving support information for switch:ras010, module:ENC_LOGGER...
Saving support information for switch:ras010, module:AN_DEBUG...
.....

Saving support information for switch:ras010, module:AMS_MAPS_LOG...
Saving support information for switch:ras010, module:FLOW_VISION_LOG...
Saving support information for switch:ras010, module:MP_LOG...
Saving support information for switch:ras010, module:DM_FTR_FFDC...
.....
Saving support information for switch:ras010, module:CORE_FFDC...
No core or FFDC data files found!
Saving support information for switch:ras010, module:RAS_POST...
.....

SupportSave completed.

```

tempShow

Use this command to display temperature readings of blade temperature sensors. The command displays the following information:

- Sensor ID (an index number)
- Slot number
- Sensor index (when command issued with the--detail option)
- Sensor state (OK or absent)
- Temperature in both Centigrade and Fahrenheit

Following is an example of **tempShow** output.

```
chassisX6-8:admin> tempshow
Sensor Slot  Sensor State      Centigrade  Fahrenheit
  ID          Index
-----
 1         3         0      Ok           30           86
 2         3         1      Ok           53          127
 3         4         0      Ok           31           87
 4         4         1      Ok           50          122
 5         5         0      Ok           29           84
 6         5         1      Ok           29           84
 7         5         2      Ok           40          104
 8         5         3      Ok           46          114
 9         6         0      Ok           29           84
10         6         1      Ok           30           86
11         6         2      Ok           42          107
12         6         3      Ok           46          114
13         1         0      Ok           41          105
14         1         1      Ok           36           96
15         1         2      Ok           38          100
16         1         3      Ok           36           96
17         2         0      Ok           37           98
18         2         1      Ok           32           89
19         2         2      Ok           35           95
20         2         3      Ok           33           91
21         7         0      Ok           30           86
22         7         1      Ok           58          136
23         7         2      Ok           51          123
24         7         3      Ok           48          118
25         7         4      Ok           43          109
26         8         0      Ok           30           86
27         8         1      Ok           59          138
28         8         2      Ok           52          125
29         8         3      Ok           48          118
30         8         4      Ok           42          107
31         9         0      Ok           31           87
32         9         1      Ok           55          131
33        10         0      Ok           29           84
34        10         1      Ok           30           86
35        10         2      Ok           42          107
36        10         3      Ok           48          118
37        11         0      Ok           29           84
38        11         1      Ok           30           86
39        11         2      Ok           40          104
40        11         3      Ok           46          114
41        12         0      Ok           29           84
42        12         1      Ok           30           86
43        12         2      Ok           43          109
44        12         3      Ok           50          122
```

Note the following about this output:

- The absent state simply reflects that the blade slot is empty.
- The sensor index is mainly for support use.
- Multiple sensors are commonly averaged to determine thresholds used for managing fan speeds or for determining a high temperature condition that may require that the blade be shut off.

Running diagnostic tests

Diagnostic tests are automatically run during POST to check the status of the device. Any error messages generated during POST are sent to the error logs and to the serial console, if connected.

Diagnostic tests can also be run manually to test and troubleshoot the hardware and the firmware, including internal connections and circuitry, transceivers, and port cables. However, diagnostic tests are generally intended for use by support personnel.

Note: Error messages do not necessarily indicate that the device requires maintenance.

Each diagnostic test can be implemented by entering the related command through a Telnet or serial session. For a list of diagnostic tests and commands, refer to the *Fabric OS Administrator's Guide*.

All diagnostic tests are run at all supported link speeds. They might temporarily lock the transmit and receive speeds to a specific speed. Some diagnostic tests require interconnecting the ports to each other or using loopback plugs. If ports are interconnected, the media (cables and transceivers) at each end of the connection must be of the same type. For example, short wavelength media must be connected to short wavelength media, and likewise with long wavelength media and copper media.

For more information about diagnostic tests and how to run them, refer to the *Fabric OS Administrator's Guide* and the *Fabric OS Command Reference*. For information about system error messages (**errShow** or **errDump**), refer to the *Fabric OS Troubleshooting and Diagnostics Guide*.

Chapter 7. Port and Extension Blades

This chapter provides the following information:

- “Port blade overview”
- “Extension blade overview” on page 99
- “Precautions specific to the blade” on page 102
- “Faulty blade indicators” on page 103
- “Removing a blade” on page 103
- “Installing a blade” on page 105
- “Verifying blade operation” on page 106

Port blade overview

The FC32-48 port blade contains 48 ports capable of Fibre Channel (FC) speeds up to 32 Gbps. Port blades connect to core routing blades through backplane ports. Each core routing blade provides 96 backplane ports for port blade connection. The port blade supports port-based in-flight encryption/decryption and compression/decompression.

Port and extension blades can be mixed in device slots 3-6 and 9-12, but CR32-8 blades must be installed in slots 7 and 8. Up to eight hot-swappable port blades can be installed in a single chassis to provide up to 384 32 Gbps FC ports.

The following optics can be installed in the blade's FC ports:

- 32 Gbps SFP+ transceivers supporting speeds 8,16, and 32 Gbps.
- 16 Gbps SFP+ transceivers supporting speeds of 4, 8, and 16 Gbps.
- 10 Gbps SFP+ transceivers supporting 10 Gbps.

Port blades contain the following LED indicators:

- Green blade power LED
- Amber blade status LED
- Bicolor green/amber FC port status LEDs

For details on interpreting LED operation, refer to “Interpreting port blade LEDs” on page 61.

FC32-48 blade port numbering and trunking

The following illustration shows how ports are numbered and port trunking groups are arranged on the blade.

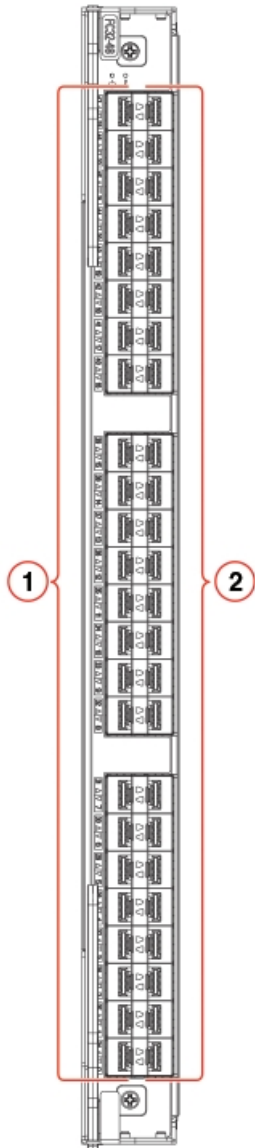

Figure 32. FC32-48 blade port numbering

- 1 - FC ports 0–23 (numbered bottom to top)
- 2 - FC ports 24–47 (numbered bottom to top)

Following are the eight-port Fibre Channel port groups for configuring trunk groups or "trunks." Color coding on the physical blade identifies the port groups. On the blade, ports belonging to the same port group are indicated with the same color border beneath the port on the blade label. Ports belonging to the same ASIC are indicated by a border with a similar color tone.

- 0–7
- 8–15
- 16–23
- 24–31
- 32–39
- 40–47

Following are the requirements for forming trunk groups:

- All ports in a trunk group must belong to the same port group. For example, to form an 8-port trunk select all eight ports from port group 0 or port group 1. You cannot use ports from each port group for the trunk.
- You can use from 1–8 ports in a port group to form a trunk.
- All ports in a trunk must be running at the same speed.
- All ports in a trunk must be configured for the same distance.
- All ports in a trunk must have the same encryption, compression, QoS, and FEC settings.
- Trunk groups must be created between switches (or adapters in the case of F_Port trunking). trunking is proprietary and is not supported on M-EOS or third-party switches.
- There must be a direct connection between participating switches.

Extension blade overview

The SX6 Extension blade is intended as an extension platform to support Fibre Channel (FC), FICON, and IP based storage data flows. IBM Extension enables you to use the existing IP wide area network (WAN) infrastructure to connect Fibre Channel and IP fabrics. Extension supports applications such as remote data replication (RDR), centralized backup, and data migration over very long distances that are impractical or very costly using native Fibre Channel or IP connections. Extension tunnels, built on a physical connection between two extension switches or blades, allow Fibre Channel and IP I/O to pass through the IP WAN. The SX6 Extension blade can connect with an SX6 blade in another SAN512B-6 or with a 7840 Extension Switch.

Port and extension blades can be mixed in in device slots 3–6 and 9–12, but CR32-8 blades must be installed in slots 7 and 8. You can install a maximum of four SX6 blades in the device.

The SX6 blade have the following external ports:

- 16 Fibre Channel (FC) SFP+ ports that support Fibre Channel Routing Services and connection to FC devices for the IBM Extension feature. These ports support 32 Gbps transceivers operating at 8, 16, or 32 Gbps, 16 Gbps transceivers operating at 4, 8, or 16 Gbps, and 10 Gbps transceivers operating at fixed 10 Gbps. FC ports can autonegotiate speeds with connecting ports.
- 16 10 or 1 GbE SFP+ and two 40 GbE QSFP ports. These ports allow connection of blades to IP WANs and allow Fibre Channel and IP I/O to pass through the IP WAN using extension tunnels. The 10 or 1 GbE ports operate at 10 Gbps or 1 Gbps fixed speeds with appropriate 10 Gbps or 1 Gbps transceivers installed. The 40 GbE QSFP ports operate at 40 Gbps fixed speed.

Extension blades have the following LED indicators:

- Green blade power LED
- Amber blade status LED
- Bicolor green/amber 40 GbE and 10 or 1 GbE port status LEDs
- Bicolor green/amber FC port status LEDs

For details on interpreting LED operation, refer to “Interpreting extension blade LEDs” on page 64.

All features are supported on this blade with no license requirements.

Extension features

The SX6 Extension blade supports the following extension features.

Note: For full details on extension blade features and configuration, refer to the *Fabric OS Extension Administrator's Guide*.

- Connectivity with another SX6 extension blade or the 7840 Extension Switch.
- Multiple logical extension tunnels with maximum tunnel bandwidth up to 40 Gbps (FCIP mode) allow for scalable connections between sites.
- Extension trunking feature allows multiple IP source and destination address pairs (defined as circuits) via multiple 10 GbE or 40 GbE interfaces to provide high bandwidth extension tunnel and lossless failover resiliency. In addition, each extension circuit supports four QoS classes (class-F, high, medium and low priority), each as a TCP connection.
- ARL feature meets minimum bandwidth guarantee for each tunnel while making the full utilization of the available network bandwidth without adverse throughput performance impact at high traffic load.
- Hardware-based compression delivers the ability to maximize throughput over lower bandwidth links in the wide area network, optimizing the cost efficiencies of FCIP. The SX6 blade compresses FC frames before they are encapsulated into FCIP packets.
- Key protocol features are enabled in the FCIP implementation to optimize performance of extension over IP networks, including WAN Optimized TCP (WO-TCP), 9K jumbo frame and end-to-end Path MTU auto discovery.
- Hardware-based IPsec supports mix of secure and non-secure tunnels on the same Ethernet port, jumbo frames, and VLAN tagged connections. The IPsec function is capable of supporting both IPv4 and IPv6.
- FastWrite, Open Systems Tape Pipelining and Advanced Accelerator for FICON mitigate the latency effect of a long distance FCIP distance connection over IP WAN.
- Extension HCL (Hot Code Load) provides In-service firmware upgrade for supporting 24/7 non-stop business operations
- Built-in WAN link tester generates traffic over an IP connection to test for maximum throughput, congestion, loss percentage, out of order deliver, latency, and other network conditions. It helps determine the health of a WAN link before deploying it for use.
- Fabric Vision advanced monitoring provides the following functions:
 - Policy based monitoring monitors extension connectivity and WAN anomalies using multi-layer metrics.
 - Flow monitoring reports IOPS and data rate of individual I/O flows of inter-DC replication and tape backup operations.
 - Flow generator generates FC frames for a defined flow with default or custom size and pattern and sent across extension tunnel to help validate end to end network setup and configuration.
- Extended distance Fibre Channel supports long distance native FC connectivity.
- Extension tunnels and circuits:
 - A maximum of 8 circuits can be configured per tunnel.
 - A maximum of 20 tunnels (VE_Ports) can be configured for all GbE ports.
 - The maximum committed rate of a single circuit is 10 Gbps, whether configured on a 10 GbE or 40 GbE port.
- FCIP and hybrid mode (FC + IP) modes.

SX6 blade port numbering and trunking

The following illustration shows how ports are numbered on the blade. Ports are labeled as 10GE, 40 GbE, and FC on the blade.

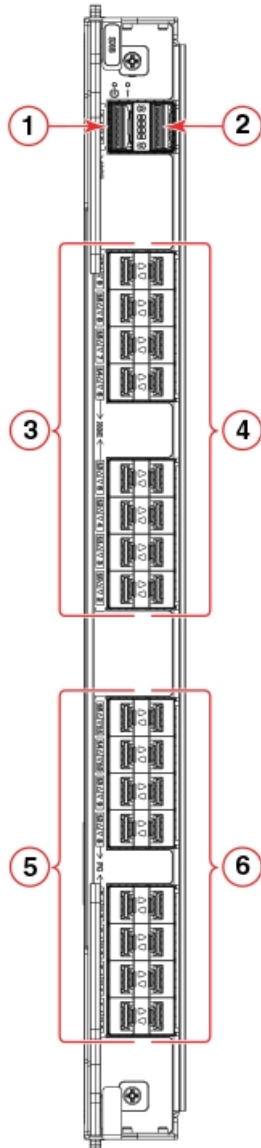

Figure 33. SX6 extension blade port numbering

- 1 - 40 GbE port 0
- 2 - 40 GbE port 1
- 3 - 10/1 GbE ports 2–9 (bottom to top)
- 4 - 10/1 GbE ports 10–17 (bottom to top)
- 5 - FC ports 0, 1, 2, 3, 8, 9, 10, 11 (bottom to top)
- 6 - FC ports 4, 5, 6, 7, 12, 13, 14, 15 (bottom to top)

Following are the eight-port Fibre Channel port groups for configuring trunk groups or "trunks":

- Port group 0: ports 0–7
- Port group 1: ports 8–15

Following are the requirements for forming trunk groups:

- All ports in a trunk group must belong to the same port group. For example, to form an 8-port trunk select all eight ports from port group 0 or port group 1. You cannot use ports from each port group for the trunk.
- You can use from 1–8 ports in a port group to form a trunk.
- Ports must be running at the same speed.
- Ports must be configured for the same distance.
- Ports must have the same encryption, compression, QoS, and FEC settings.
- Trunk groups must be created between switches (or adapters in the case of F_Port trunking). trunking is proprietary and is not supported on M-EOS or third-party switches.
- There must be a direct connection between participating switches.

For full details on trunking requirements and configuration, refer to the *Fabric OS Administrator's Guide*.

Precautions specific to the blade

This document describes how to remove and replace a port or extension blade.

Observe the following precautions when replacing these blades:

- The SX6 extension and FC32-48 port blade can only be installed in SAN512B-6 and SAN256B-6 switches.
- Wear an appropriately grounded ESD wrist strap when handling and installing device blades and cards. Follow electrostatic discharge (ESD) precautions. Wear a wrist grounding strap connected to chassis ground (if the chassis is plugged in) or a bench ground.
- Install port and extension blades only in slots 3–6 and 9–12. Slots 7 and 8 are reserved for CR32-8 blades. These blades cannot be installed in other slots as guide pins and connectors in each slot allow only specific blade types.



CAUTION:

For safety reasons, the ESD wrist strap should contain a series 1 megaohm resistor.



CAUTION:

If you do not install a module or a power supply in a slot, you must keep the slot filler panel in place. If you run the chassis with an uncovered slot, the system will overheat.



CAUTION:

Static electricity can damage the chassis and other electronic devices. To avoid damage, keep static-sensitive devices in their static-protective packages until you are ready to install them.



CAUTION:

Before plugging a cable into any port, be sure to discharge the voltage stored on the cable by touching the electrical contacts to ground surface.



CAUTION:

To avoid damaging blade and chassis, do not use ejector handles to push the blade into or pull the blade out from a slot.

Faulty blade indicators

Confirm that you need to replace the blade before continuing. The following events may indicate that a blade is faulty:

- The status LED on the blade is lit steady amber, or the power LED is not illuminated.
- The `slotShow` command does not show that the blade is enabled.
- `errShow` - Displays error log messages one at a time.
- Any of the following messages display in the error log or "show" command output:
 - "Slot unknown" message relating to the blade slot
 - FRU: FRU_FAULTY messages for the blade
 - FAULTY (xx) with an associated (xx) code used by support

For output examples and additional information on Fabric OS commands, refer to "Using monitoring commands" on page 77 and the *Fabric OS Command Reference*.

For more information about error messages, refer to the *Fabric OS Message Reference*.

Time and items required for removal and installation

The removal or installation procedure for each blade takes less than 10 minutes. Removing and restoring transceivers and cables may take longer depending on how many must be changed. The following items are required for the blade and filler panel replacement:

- Electrostatic discharge (ESD) grounding strap
- Workstation computer
- Replacement blade or filler panel
- #1 Phillips screwdriver
- SFP, SFP+, or SFP28 transceivers (as needed)
- Optical and copper cables (as needed)

Note: For information about the transceivers that are qualified for this device, refer to Chapter 5, "Installing Transceivers and Cables," on page 49.

Removing a blade

Before you begin

- Before removing any cables from a blade, note the cable order (identify each cable by its physical port).
- It is a good practice to create a table of cable to port mapping for reference.
- If multiple blades are being replaced, replace one blade at a time.

About this task

Use the following steps to remove a port or extension blade from the unit while system power is on. This procedure is applicable for all the port and extension blades supported on the device.

Procedure

1. Remove the chassis door.
2. Check the blade power and status LEDs and port status LEDs on the front of each blade to identify any possible problems.
3. Before replacing a blade, establish a Telnet or console connection to determine a failure and verify operation after replacement. Use the **switchShow** and **slotShow** commands to view the status of the blades.
4. Check for adequate cable slack. Ensure there is plenty of cable slack to remove a blade without cable obstruction.
5. Ensure that the part number on the unit being replaced matches the replacement part number. The **chassisShow** command displays information about the blades, including part numbers (*xx-xxxxxx-xx*), serial numbers, and additional status.
6. Ensure that traffic is not flowing through the blade (port status LED should be off) prior to disconnecting cables.
7. Disconnect all cables and remove transceivers from the blade.
8. If removing an extension blade, perform the following steps:
 - a. Delete all fcip tunnel configurations using the **portcfg fcip tunnel slot/vePort delete** command.
 - b. Delete all IP Routes defined on the blade to be removed using the **portcfg iproute delete** command.
 - c. Delete all IP interfaces (IPIFs) defined on the blade using the **portcfg ipif slot/geX delete** command.
 - d. If logical switches are used on the switch, move all blade ports back to the default logical switch. Refer to the **lscfg** command in the *Fabric OS Command Reference* for details.

Note: If you are removing the extension blade to install in a different slot, you must remove configuration using the preceding steps, then reconfigure the blade in the new slot. If you move the blade without performing these steps and the blade faults, you must move the blade to the original slot and remove configuration.

9. Loosen the captive screws for both ejector handles on the blade using a #1 Phillips screwdriver. Loosening the screws initiates a hot-swap request and disconnects power from the blade. The spring-loaded captive screws will pop out from the slot .63 cm (.25 in.) when fully disengaged. Do not eject the blade using blade handles until screws disengage from slot and the power LED is off.
10. Grasp both ejector handles and simultaneously pull them away from the center of the blade using equal pressure to approximately 45 degrees (fully open). As you move the handles, you will hear connectors disengaging from the backplane connector and possibly a slight popping noise. This is normal and is due to the dense backplane. The blade will move out approximately 1.27 cm (.5 in.) from the slot when fully disengaged.
11. Pull the blade out from the slot slightly using the ejector handles until you can grasp the blade edges with your hands. Make sure that the blade has cooled sufficiently to touch.

CAUTION:

To avoid damaging blade and chassis, do not push the blade into a slot or pull the blade from a slot using the ejector handles.

12. Continue pulling the blade from the slot by the blade edges. As you slide out the blade, place one hand under it for support. Do not support the blade by

the injector handles after removal.

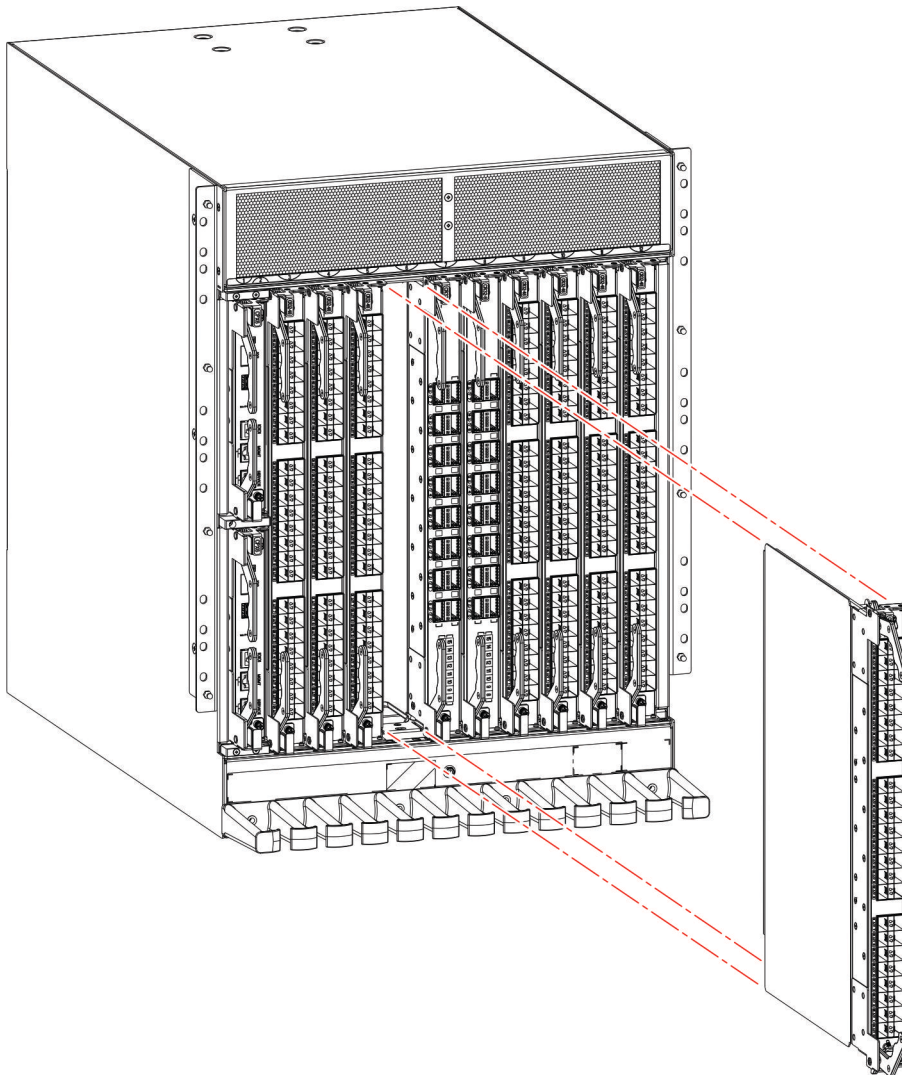

Figure 34. Removing and replacing port or extension blade

13. If the blade is not being replaced by another blade, install a filler panel and reinstall the chassis door. The filler panel is required for proper chassis cooling. The door is required to meet EMI compliance.

Installing a blade

About this task

Complete this procedure to install a port or extension blade. These steps apply to all port and extension blades installed in the device.

Procedure

1. If a protective sleeve is covering the blade connectors remove the sleeve.
2. Rotate the ejector handles away from center of blade completely - approximately 45 degrees. Do not support the blade using ejector handles. Orient the blade so that the handles are toward you and the flat metal side is facing down.
3. Follow these steps to insert the blade into the slot.

- a. Align the blade in the slot with the flat metal side of the blade at the bottom (blade power and status LEDs are on the left).
- b. Carefully push the blade into the slot using your thumbs or fingers on the blade faceplate. When the blade face is about 2.54 cm (1 in.) from the chassis, you should feel resistance as the blade connectors meet the backplane connectors.

CAUTION:

To avoid damaging blade and chassis, do not use ejector handles to push the blade into or pull the blade out from a slot.

- c. Continue pushing the blade into slot using your thumbs or fingers until the ejectors move in towards the blade slightly indicating that the connectors are engaged.
- d. Simultaneously push both ejector handles in towards the blade center with even pressure until the blade completely seats in the slot.

Note: As you move the handles, you will hear connectors engaging the backplane connector and possibly a slight popping noise. This is normal and is due to the dense backplane.

4. Tighten the captive for each ejector using a #1 Phillips screwdriver. As blade seats completely, amber blade status and green blade power LEDs illuminate.

Note: Be sure that captive screws are tightened. If not, high pressure from fan operation may unseat blade from chassis connectors.

5. Observe the blade power and status LEDs and verify the following:
 - a. Verify that the status LED on the blade shows amber until POST completes for the blade. The status LED should then display green to indicate that the blade has power. If the status LED remains amber, the board may not be properly seated in the backplane or the board may be faulty.
 - b. Verify that the power LED on the port blade is displaying a steady green light to indicate that the blade has power. If it does not turn on, ensure that the blade is firmly seated and ejector captive screws are tightened.
6. Install the transceivers and cables in the blade.
7. Group and route the cables through the cable management comb.
8. Replace the chassis door. The door is required to meet EMI compliance.

Verifying blade operation

About this task

Perform the following tasks to verify operation of blade:

Procedure

1. Check the LED indicators on the blade's front panel. For information on interpreting LED patterns, refer to one of the following sections of this guide:
 - "Interpreting port blade LEDs" on page 61.
 - "Interpreting extension blade LEDs" on page 64.
2. Enter the following commands and note any error conditions:
 - **slotshow -p** - Displays the current data on each slot in the system, including blade type, blade ID, status, and IBM model name.
 - **tempShow** - Displays temperature reading of blades.
 - **chassisShow** - Displays information about each component in the system.

- **sensorShow** - Displays temperature reading of blades with fan and power supply status.
- **errDump** - Displays the entire system error log.
- **errShow** - Displays error log messages one at a time.

Example

For output examples and additional information on Fabric OS commands, refer to “Using monitoring commands” on page 77 and the *Fabric OS Command Reference*.

For more information about error messages, refer to the *Fabric OS Message Reference*.

Chapter 8. Core Routing Blades

This chapter provides the following information:

- “Core routing blade overview”
- “Precautions specific to the blade” on page 114
- “Faulty core routing blade indicators” on page 114
- “Removing a core routing blade” on page 115
- “Installing a core routing blade” on page 117
- “Verifying blade operation” on page 118

Core routing blade overview

Two CR32-8 core routing blades are installed in device slots 7 and 8. Core routing blades contain ASICs that allow switching between up to eight port blades. Core routing blades connect to port blades through Fibre Channel backplane ports. Each core switch blade provides 192 backplane ports for port blade connections. Each core routing blade also has 64 front-end ports that are mapped to 16 QSFP transceivers on the blade's front panel. These transceivers can create ICL connections for up to nine separate switches in a full-mesh topology and 12 switches in a core-to-edge topology. Each transceiver provides four 32 Gbps FC links for a total of 128 Gbps per connection. This core switch blade is compatible only with the SAN512B-6.

Core routing blades contain the following LED indicators:

- Green blade power LED
- Amber blade status LED
- Bicolor green/amber QSFP port status LEDs

For details on interpreting LED operation, refer to “Interpreting core routing blade LEDs” on page 69.

CR32-8 port numbering

The following illustration shows how ports are numbered and port trunking groups are arranged on the blade.

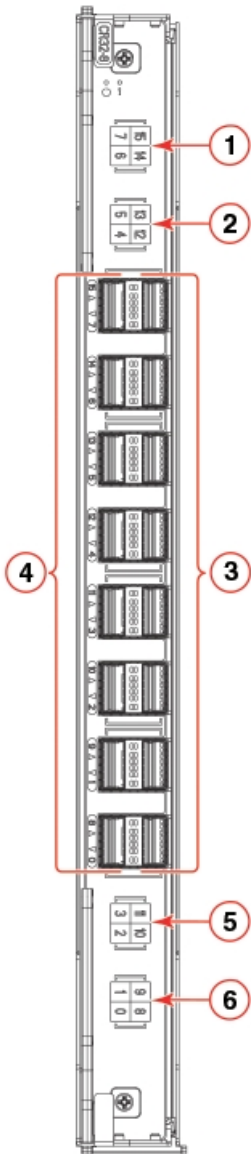

Figure 35. CR32-8 core routing blade port numbering

- 1 - Map showing ports 6, 7, 14, and 15
- 2 - Map showing ports 4, 5, 12, and 13
- 3 - QSFP ports 8-15 (bottom to top)
- 4 - QSFP ports 0-7 (bottom to top)
- 5 - Map showing ports 2, 3, 10, 11
- 6 - Map showing ports 0, 1, 8, 9

QSFP ports are numbered from 0 through 7 on the left side from bottom to top and 8 through 15 on the right side from bottom to top. For information on supported QSFP transceivers, refer to “Supported transceivers and cables” on page 49.

Ports belonging to the same trunking groups are indicated with the same color border under the ports. These colors are also applied to the port map labels on each blade to indicate ports belonging to the same trunking groups.

Each numbered QSFP port on the blade provides four 32 Gbps FC ports to obtain a total link speed of 128 Gbps. The following table shows the mappings from the numbered QSFP ports on the face of the core blade to the individual FC port numbers.

Table 17. External port to slotShow port mapping for core blades

External port number	FC port numbers	External port number	FC port numbers
0	0-3	8	32-35
1	4-7	9	36-39
2	8-11	10	40-43
3	12-15	11	44-47
4	16-19	12	48-51
5	20-23	13	52-55
6	24-27	14	56-59
7	28-31	15	60-63

ICL trunking groups

Multiple switches can be connected through inter-chassis links (ICLs) between 4x32-Gbps QSFPs on core routing blades installed in these devices. Each QSFP connection between two devices provides 128 Gbps bandwidth. Trunking optimizes the use of ICL bandwidth by allowing a group of links to merge into a single logical link, called a trunk. Traffic is distributed dynamically and in order over this trunk, achieving greater performance with fewer links. Within the trunk, multiple physical ports appear as a single port, thus simplifying management. Trunking also improves system reliability by maintaining in-order delivery of data and avoiding I/O retries if one link within the trunk fails.

Each QSFP provides four 32 Gbps FC ports. Since each port within a QSFP terminates on a different ASIC within each core blade, an ICL trunk cannot be formed using the individual FC ports within the same QSFP. A trunk has to be formed from individual FC ports in different QSFP ports. These QSFP ports must reside in the same trunk group. To form an ICL trunk between two devices, a minimum of two QSFPs within a port trunk group on a core blade installed in one device must be connected to a pair of QSFPs within a trunk group on a core blade in another device using ICLs.

Each CR32-8 blade on the SAN512B-6 has four ICL trunking groups consisting of the following QSFP ports.

- 0, 1, 8, and 9
- 2, 3, 10, and 11
- 4, 5, 12, and 13
- 6, 7, 14, and 15

Ports belonging to the same trunking groups are indicated with the same color border under the ports on the blade faceplate. These colors are also applied to the port map labels on each blade faceplate to indicate ports belonging to the same trunking groups.

For more information on ICLs and configuring ICL trunking between core routing blades on GEN6 and GEN5 switches, refer to the "Inter-Chassis Links" in the *Fabric OS Administrator's Guide*.

For more information recommended cabling topologies for ICLs, refer to "ICL cabling configurations."

Note: You cannot configure ISLs using ports on port blades and QSFP-based ICLs using ports on core routing blades concurrently on the same chassis.

ICL cabling configurations

The following figures show acceptable cabling configurations for the inter-chassis link (ICL) feature between QSFP ports in core routing blades. The recommended topology is the parallel type where at least four QSFP cables connect between both core routing blades on any two switches. This provides ICL trunking between switches, ensuring redundancy. Parallel connections between core blades are recommended. Up to nine switches can be connected in a full-mesh topology and 12 switches in a core-to-edge topology using the 4x32-Gbps quad SFP (QSFP) inter-chassis links (ICLs).

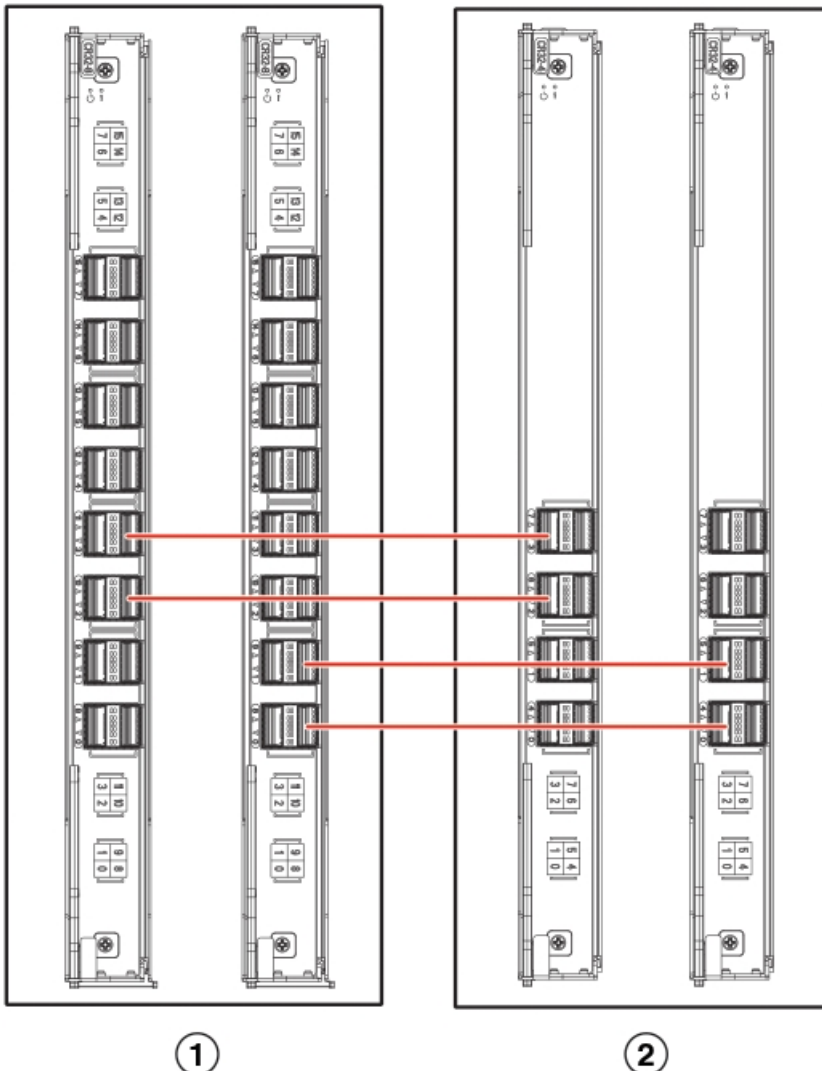

Figure 36. ICL cable connections (sample configuration)

- 1 - Chassis 1 - SAN512B-6
- 2 - Chassis 2 - SAN256B-6

To connect multiple switches via ICLs, a minimum of four ICL ports (two on each core routing blade) must be connected between each chassis. The dual connections on each core blade must reside within the same trunk group. If more than four ICL connections are required between a pair of switches, additional ICL connections should be added in pairs (one on each core blade). ICLs and ISLs are not concurrently supported between a single pair of switches.

The switch can be connected in a core-edge configuration. The following figure shows two core and four edge devices. Although SAN512B-6 switches are shown in the figure, the device can be either SAN256B-6 or SAN512B-6 switches. The cabling scheme should follow the parallel example shown in the previous figure. Each line in the example actually represents four cables running between the devices.

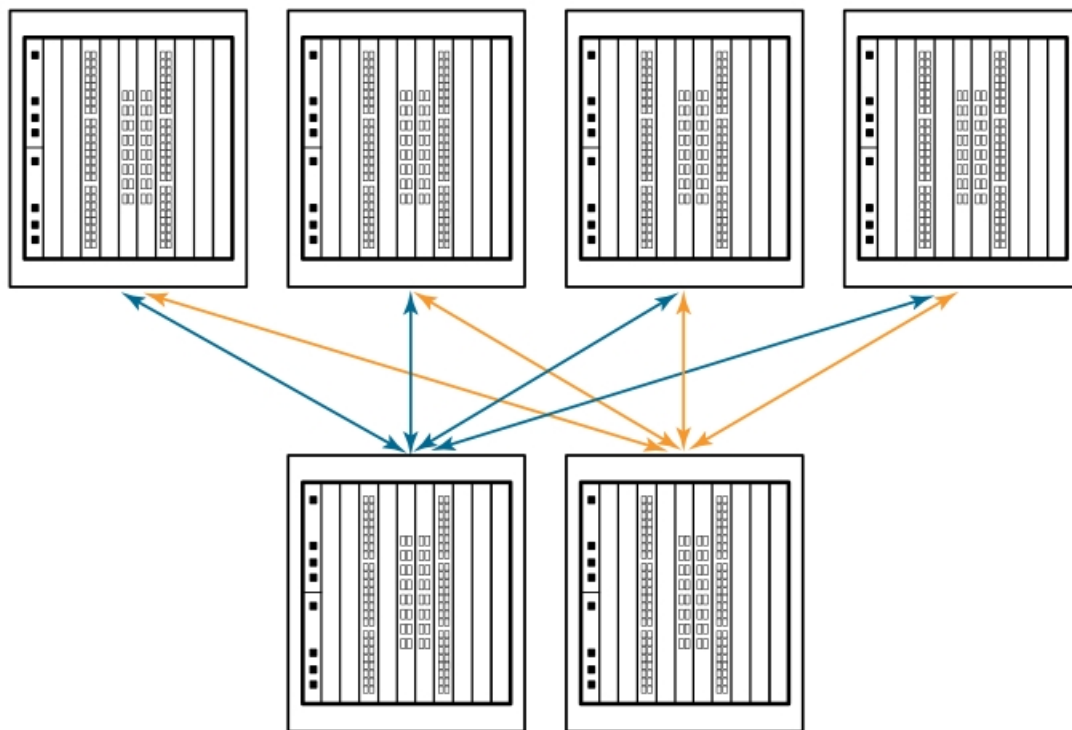

Figure 37. Core-edge ICL topology

SAN512B-6 and SAN384B-2 or SAN768B-2 can also be connected in a full-mesh configuration.

For details on the following subjects, refer to the "Inter-Chassis Links" section of the *Fabric OS Administrator's Guide*:

- ICL topologies
- ICL trunking
- Configuring ICLs between SAN512B-6 and SAN256B-6
- Configuring ICLs between SAN512B-6 or SAN256B-6 and SAN384B-2 or SAN768B-2 models

Precautions specific to the blade

This document describes how to remove and replace a core routing blade.

Observe the following precautions when replacing these blades:

- The CR32-8 core routing blade is compatible only with the SAN512B-6 .
- Wear an appropriately grounded ESD wrist strap when handling and installing blades and cards. Follow electrostatic discharge (ESD) precautions. Wear a wrist grounding strap connected to chassis ground (if the chassis is plugged in) or a bench ground.
- Install core routing blades only in slots 7-8. These blades cannot be installed in other slots as guide pins and connectors in each slot allow only specific blade types.



DANGER

For safety reasons, the ESD wrist strap should contain a series 1 megaohm resistor.



CAUTION:

If you do not install a module or a power supply in a slot, you must keep the slot filler panel in place. If you run the chassis with an uncovered slot, the system will overheat.



CAUTION:

Static electricity can damage the chassis and other electronic devices. To avoid damage, keep static-sensitive devices in their static-protective packages until you are ready to install them.



CAUTION:

Before plugging a cable into any port, be sure to discharge the voltage stored on the cable by touching the electrical contacts to ground surface.



CAUTION:

To avoid damaging blade and chassis, do not push the blade into a slot or pull the blade from a slot using the ejector handles.

Faulty core routing blade indicators

Confirm that you need to replace the blade before continuing. The following events may indicate that a core routing blade is faulty:

- The status LED on the core switch blade is lit steady amber, or the power LED is not illuminated.
- The **slotShow** command does not show that the core switch blade is enabled.
- Any of the following messages display in the error log or "show" command output:
 - "Slot unknown" message relating to a core switch slot
 - Core switch blade errors or I2C timeouts
 - FRU: FRU_FAULTY messages for a core switch blade
 - FAULTY (xx) with an associated code used by support

- Configuration loader messages or "Sys PCI config" messages
- Generic system driver messages ("FABSYS")
- Platform system driver messages ("Platform")
- EM messages that indicate a problem with a core switch blade
- Function fail messages for the core switch master

Refer to "Using monitoring commands" on page 77 and the *Fabric OS Command Reference* for output examples and additional information on Fabric OS commands.

For more information about error messages, refer to the *Fabric OS Message Reference*.

Time and items required

The replacement procedure for the core switch blade takes approximately 30 minutes. The following items are required for the core switch blade replacement:

- Electrostatic discharge (ESD) grounding strap
- Workstation computer
- Replacement blade or filler panel
- #1 Phillips screwdriver
- QSFP transceivers (as needed)
- Optical cables (as needed)

Note: For information about the transceivers that are qualified for this device, refer to Chapter 5, "Installing Transceivers and Cables," on page 49.

Removing a core routing blade

About this task

Complete the following steps to remove the core routing blade.

Note: The device continues to operate while a core routing blade is being replaced.

Procedure

1. Remove the chassis door.
2. Check the blade power and status LEDs and port status LEDs on the front of each blade to identify any possible problems.
3. Before replacing a blade, establish a Telnet or console connection to determine a failure and verify operation after replacement. Use the **switchShow** and **slotShow** commands to view the status of the blades.
4. Check for adequate cable slack. Ensure there is plenty of cable slack to remove a blade without cable obstruction.
5. Ensure that the part number on the unit being replaced matches the replacement part number. The **chassisShow** command displays information about the blades, including part numbers (*xx-xxxxxxx-xx*), serial numbers, and additional status.
6. Ensure that traffic is not flowing through the blade (port status LED should be off) prior to disconnecting cables.
7. Disconnect all cables and remove transceivers from the blade.
8. Label and then disconnect cables from the faulty core routing blade.

9. Loosen the captive screws for both ejector handles on the blade using a #1 Phillips screwdriver. Loosening the screws initiates a hot-swap request and disconnects power from the blade. The spring-loaded captive screws will pop out from the slot .63 cm (.25 in.) when fully disengaged. Do not eject the blade using blade handles until screws disengage from slot and the power LED is off.
10. Grasp both ejector handles and simultaneously pull them away from the center of the blade using equal pressure to approximately 45 degrees (fully open). As you move the handles, you will hear connectors disengaging from the backplane connector and possibly a slight popping noise. This is normal and is due to the dense backplane. The blade will move out approximately 1.27 cm (.5 in.) from the slot when fully disengaged.
11. Pull the blade out from the slot slightly using the ejector handles until you can grasp the blade edges with your hands. Make sure that the blade has cooled sufficiently to touch.

CAUTION:

To avoid damaging blade and chassis, do not push the blade into a slot or pull the blade from a slot using the ejector handles.

12. Continue pulling the blade from the slot by the blade edges. As you slide out the blade, place one hand under it for support. Do not support the blade by the injector handles after removal.

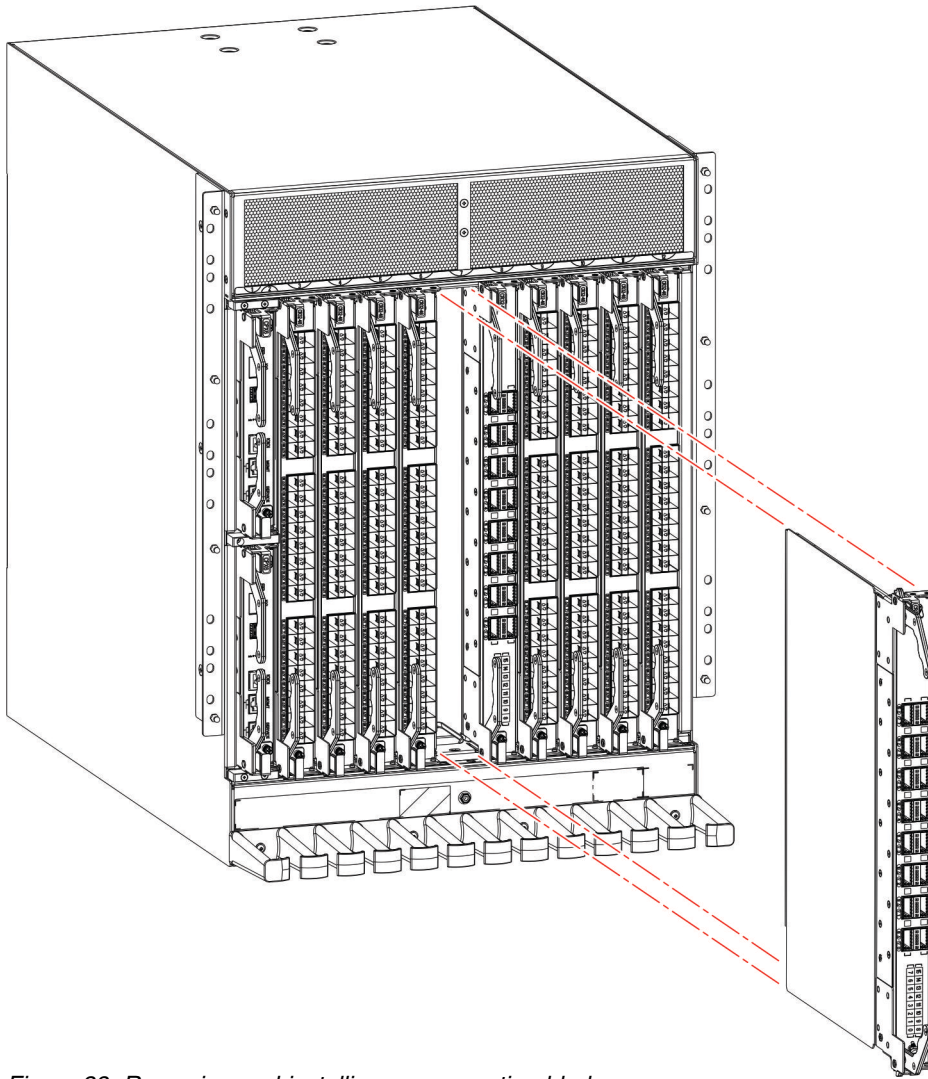

Figure 38. Removing and installing a core routing blade

13. If the blade is not being replaced by another blade, install a filler panel and reinstall the chassis door. The filler panel is required for proper chassis cooling. The door is required to meet EMI compliance.

Installing a core routing blade

About this task

Complete the following steps to replace the core routing blade.

Note: The device continues to operate while a core routing blade is being replaced.

Procedure

1. If a protective sleeve is covering the blade connectors remove the sleeve.
2. Rotate the ejector handles away from center of blade completely - approximately 45 degrees. Do not support the blade using ejector handles. Orient the blade so that the handles are toward you and the flat metal side is facing down.
3. Follow these steps to insert the blade into the slot.

- a. Align the blade in the slot with the flat metal side of the blade at the bottom (blade power and status LEDs are on the left).
- b. Carefully push the blade into the slot using your thumbs or fingers on the blade faceplate.

CAUTION:

To avoid damaging blade and chassis, do not use ejector handles to push the blade into or pull the blade out from a slot.

When the blade face is about 2.54 cm (1 in.) from the chassis, you should feel resistance as the blade connectors meet the backplane connectors.

- c. Continue pushing with your thumbs or fingers until the ejectors move in towards the blade slightly indicating that the connectors are engaged.
- d. Simultaneously push both ejector handles in towards the blade center with even pressure until the blade completely seats in the slot.

Note: As you move the handles, you will hear connectors engaging the backplane connector and possibly a slight popping noise. This is normal and is due to the dense backplane.

4. Tighten the captive for each ejector using a #1 Phillips screwdriver. As blade seats completely, amber blade status and green blade power LEDs illuminate.

Note: Be sure that captive screws are tightened. If not, high pressure from fan operation may unseat blade from chassis connectors.

5. Observe the blade power and status LEDs and verify the following:
 - a. Verify that the status LED on the blade shows amber until POST completes for the blade, then turns off. If the status LED remains amber, the board may not be properly seated in the backplane or the board may be faulty.

Note: POST may take several minutes to complete on these blades.

- b. Verify that the power LED on the port blade is displaying a steady green light to indicate that the blade has power. If it does not turn on, ensure that the blade is firmly seated and ejector captive screws are tightened.
6. Install the transceivers and cables in the blade.
7. Group and route the cables through the vertical cable management finger assemblies.
8. Reinstall the chassis door. The door is required to meet EMI compliance.

Verifying blade operation

About this task

Perform the following tasks to verify operation of new blade:

Procedure

1. Check the LED indicators on the blade's front panel. For information on interpreting LED patterns, refer to "Interpreting core routing blade LEDs" on page 69. Enter the **slotShow** command and note any error conditions:
2. Enter the following commands and note any error conditions:
 - **slotShow** - Displays the current data on each slot in the system, including blade type, blade ID, status, model name, and power usage.
 - **tempShow** - Displays temperature reading of blades.
 - **sensorShow** - Displays temperature reading of blades with fan and power supply status.

- **chassisShow** - Displays information about each component in the system.
- **errDump** - Displays the entire system error log.
- **errShow** - Displays error log messages one at a time.

Example

For output examples and additional information on Fabric OS commands, refer to “Using monitoring commands” on page 77 and the *Fabric OS Command Reference*.

For more information about error messages, refer to the *Fabric OS Message Reference*.

Chapter 9. Control Processor Blades

This chapter provides the following information:

- “Control processor blade overview”
- “Precautions specific to the blade” on page 123
- “Blade fault indicators” on page 123
- “Blade replacement task guide” on page 124
- “Time and items required for replacement” on page 125
- “Preparing for replacement” on page 125
- “Replacing a CP blade” on page 126
- “Verifying blade operation” on page 136

Control processor blade overview

The CPX6 control processor blades are half the slot height of other SAN512B-6 blades. Two CPX6 control processor blades are stacked vertically in the half slots on the left side of the chassis to provide CP redundancy. CP0 is installed in slot 1, while CP1 is installed in slot 2.

The control processor (CP) blade contains the control plane for the device and hosts the Fabric OS that manages all hardware within the device. It also provides the following external connections for device configuration, firmware downloads, service, management, and monitoring functions.

- USB port for firmware download and **supportsave** data.
- Serial console RJ45 port.
- 10/100/1000Base-T RJ45 Ethernet port for device management and configuration.

Note: Half duplex operation is not supported at 10 or 100 Mbps speed.

- 10/100/1000Base-T RJ45 Ethernet port for service.
- 10 Gbps Base-T RJ45 Ethernet port (reserved for future use).

The two 10/100/1000 Mbps Ethernet ports are bound together as a single logical network interface. One port is selected as the active interface, while the other is select as the standby interface. All traffic is transmitted over the active port while no traffic is transmitted over the standby interface. If the primary Ethernet port fails (due to something other than power loss), the standby port becomes active and immediately takes over data transmission to retain link layer communication.

Note: Connecting the CP blades to a private network or VLAN is recommended.

The blade contains a blue LED to indicate active CP status, green LEDs on Ethernet ports to indicate link and activity, and green and amber LEDs to indicate blade power and status.

A bright, white beacon LED is located just beneath the blade power and status LEDs. You can enable this LED to illuminate on both CP blades so that you can

easily locate the blades and chassis in an equipment rack. To enable or disable beaconing on both blades, log into the chassis and enter the **chassisbeacon** command as follows:

- To enable beaconing:

```
chassis:admin> chassisbeacon 1
chassisBeacon success 1
```
- To disable beaconing:

```
chassis:admin> chassisbeacon 0
chassisBeacon success 0
```
- To display beaconing status:

Note: *Value* in the following example shows 0 when beaconing is off and 1 if beaconing is on.

```
chassis:admin> chassisbeacon
Value = 0
```

For details on LED location and operation, refer to “Interpreting control processor blade LEDs” on page 66.

CPX6 port identification

The following illustration identifies connector ports on the CPX6 blade.

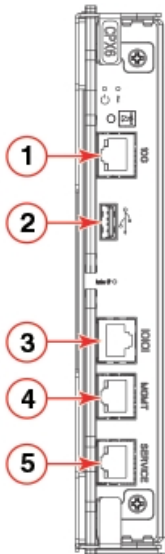

- 1 - 10 Gbps Base-T RJ45 Ethernet port (reserved for future use)
- 2 - USB port for firmware download and logs
- 3 - Serial console RJ45 port
- 4 - 10/100/1000Base-T RJ45 Ethernet port for chassis management and configuration
- 5 - 10/100/1000Base-T RJ45 Ethernet port for service

Figure 39. CPX6 blade port identification

Precautions specific to the blade

This document describes how to remove and replace a control processor (CP) blade. Each device has two CPX6 blades located in slots 1 and 2.

Observe the following precautions when replacing these blades:

- The CPX6 blade is compatible only with the SAN512B-6.
- Wear an appropriately grounded ESD wrist strap when handling and installing blades and cards. Follow electrostatic discharge (ESD) precautions. Wear a wrist grounding strap connected to chassis ground (if the chassis is plugged in) or a bench ground.
- Install CPX6 blades in slots 1 and 2, which are half the height of other slots in the device.
- The firmware upgrade policy for CP blades specifies testing for the current Fabric OS release and one version earlier. It is possible to upgrade by more than one version, but it is a very specific and detailed process. Read the directions under “Downloading firmware from USB device” on page 131 and “Downloading firmware from FTP server” on page 130 carefully.
- If the new CP blade does not have the same firmware as the active CP blade, the new blade must be upgraded to the same firmware version. After installing the new blade, you can determine the firmware version on the replacement blade and use the **firmwaresync** command to allow the active CP blade to copy current firmware to the replaced standby CP blade, if necessary. However, you must disable high availability (HA) before inserting the new blade.



CAUTION:

For safety reasons, the ESD wrist strap should contain a series 1 megaohm resistor.



CAUTION:

If you do not install a module or a power supply in a slot, you must keep the slot filler panel in place. If you run the chassis with an uncovered slot, the system will overheat.



CAUTION:

Static electricity can damage the chassis and other electronic devices. To avoid damage, keep static-sensitive devices in their static-protective packages until you are ready to install them.



CAUTION:

Before plugging a cable into any port, be sure to discharge the voltage stored on the cable by touching the electrical contacts to ground surface.



CAUTION:

To avoid damaging blade and chassis, do not use ejector handles to push the blade into or pull the blade out from a slot.

Blade fault indicators

Confirm that you need to replace the CP blade. The following events may indicate that a CP blade is faulty:

- The status LED on the CP blade is lit steady amber, or the power LED is not illuminated. Refer to “Interpreting control processor blade LEDs” on page 66 for details on interpreting LED operation.
- The CP blade does not respond to Telnet commands, or the serial console is not available.
- The **haShow** command indicates an error.
- The clock is inaccurate, or the CP blade does not boot up or shut down normally.
- Any of the following messages display in the error log:
 - “Slot unknown” message relating to a CP slot
 - CP blade errors or I2C timeouts
 - FRU: FRU_FAULTY messages for a CP blade
 - Configuration loader messages or “Sys PCI config” messages
 - Generic system driver messages (“FABSYS”)
 - Platform system driver messages (“Platform”)
 - EM messages that indicate a problem with a CP blade
 - Function fail messages for the CP master

Refer to “Using monitoring commands” on page 77 and the *Fabric OS Command Reference* for output examples and additional information on Fabric OS commands.

For more information about error messages, refer to the *Fabric OS Message Reference*.

Blade replacement task guide

This section contains a guide to more complete, detailed steps in this section for installing or replacing CP blades when the device is running (hot swap) or must be powered off (cold swap). References are provided to the more detailed blade removal and installation steps for further information.

Replacing CP blade (hot-swap)

For hot-swap replacement, the chassis continues to operate while a CP blade is being replaced if the redundant CP blade is active and a failover does not occur. You can prevent failover by entering the **haDisable** command. You can replace one blade or both blades one at a time using these steps. Follow all steps for one blade, and then repeat the same steps to replace the other blade.

1. Prepare for replacing the blade by following all steps under “Preparing for replacement” on page 125.
2. Remove the blade from the slot by following all steps under “Removing a blade” on page 127.
3. Install a new blade into the empty slot by following all steps under “Installing a blade” on page 128.
4. Verify and synchronize firmware on both blades by following all steps under “Verifying and synchronizing firmware on blades” on page 129.

If you need to download firmware to update the blades, follow steps in one of the following sections:

- “Downloading firmware from FTP server” on page 130
 - “Downloading firmware from USB device” on page 131
5. Verify firmware installation by following all steps under “Completing the replacement” on page 135.

6. Verify operation of replacement blade by following steps under “Verifying blade operation” on page 136.
7. Repeat preceding steps to replace the other CP blade if necessary.

Replacing a CP blade (cold-swap)

Use this procedure to replace CP blades after removing power to the device.

1. Prepare for replacing the blade by following all steps under “Preparing for replacement.”
2. Remove blade(s) following all steps under “Removing a blade” on page 127.
3. Install blade(s) following all steps under “Installing a blade” on page 134.
4. Verify firmware installation by following all steps under “Completing the replacement” on page 135.
5. Verify operation of replacement blade by following steps under “Verifying blade operation” on page 136.

Time and items required for replacement

The replacement procedure for the CP blade takes approximately 30 minutes. The following items are required for the CP blade replacement:

- Electrostatic discharge (ESD) grounding strap
- Workstation computer
- Serial cable
- IP address of an FTP server for backing up the device configuration
- #1 Phillips screwdriver
- Replacement CP blade

Preparing for replacement

About this task

Use the following steps to prepare the system for CP blade replacement by backing up the device configuration, connecting to the device with a serial connection, determining the active CP blade, failing over the blade to replace, determining the firmware version on the active blade, and uploading configuration data to the active blade.

Procedure

1. Back up the device configuration before you replace a CP blade by uploading various device configuration files using a Telnet connection and saving them to a host computer. Before you upload a configuration file, verify that you can reach the FTP server from the device. Perform the following steps:
 - a. Enter the **configupload -all** command, specifying a file name for saving configuration data. This saves all system configuration data including chassis and switch configuration for all logical switches to the file name specified. For more information, refer to the *Fabric OS Command Reference*.
 - b. Enter the **configupload -vf** command, specifying a file name, when prompted, for saving configuration data. This saves the backbone virtual fabric data to the file name specified. For more information, refer to the *Fabric OS Command Reference*.
 - c. In a FICON environment, log in as root and enter **configupload --map** to upload port-to-area mapping information. Specify a folder name, when

prompted. This command saves the port-to-area addressing mode configuration files to the folder specified. Be sure to upload the configuration using the **-map** option for a FICON-enabled device if port-bound addressing is used. For more information, refer to the *Fabric OS Command Reference*.

2. Connect to the device and log in as **admin**, using a serial console connection.
3. Enter **haShow** to determine which CP blade is active.

```
Chassis_1:admin> haShow
Local CP (Slot 1, CP1) : Active
Remote CP (Slot 2, CP0) : Standby, Healthy
HA Enabled, Heartbeat Up, HA State Synchronized
```

4. Enter all remaining commands from the serial console for the active CP blade, unless otherwise indicated. For more information about commands, refer to the *Fabric OS Command Reference*.
5. If the active CP blade is faulted, automatic fail over to the standby CP blade should have occurred. Perform the following steps:
 - a. Confirm that the standby CP blade is active using the **haShow** command.
 - b. Power off the faulted CP blade by loosening the captive screws on both ejector handles on the blade using a #1 Phillips screwdriver. This disconnects power from the blade. The spring-loaded captive screws will pop out from the slot .63 cm (.25 in.) when fully disengaged.
 - c. Log into the now active CP blade.
 - d. Skip to step 8.

If automatic fail over has not occurred, manually fail over the faulty blade by loosening the captive screws on both ejector handles. As the screws loosen, the blade fails over and the amber status LED will illuminate. Log into the standby CP blade, and skip to step 8.

6. If both CP blades are healthy and you want to replace the standby CP blade, log in to the active CP blade and skip to step 8.
7. If both CP blades are healthy and you want to replace the active CP blade, log in to the active CP blade and run the following steps:
 - a. Run the **haFailover** command to make the standby CP blade the active blade. The currently active CP blade becomes the standby blade. Wait until the status LED on the currently active CP blade is no longer illuminated.
 - b. Confirm the completion of the failover by running the **haShow** command.
 - c. Log in to the new active CP blade.

8. Run **firmwareShow** to note the firmware version of the active CP blade.

The **firmwareshow** command will display a warning message if the firmware versions on the two CP blades are not the same.

```
WARNING: The local CP and remote CP have different versions
of firmware, please retry firmwaredownload command.
Chassis_1:root>
```

9. Run **haDisable** from the active CP blade to prevent failover or communication between the CP blades during the replacement.

Replacing a CP blade

Use the following procedures in this section to replace CPX6 blades:

- Hot swap procedure. Use this procedure to replace a single CP blade or both CP blades, one at a time, while the device power is on. The device continues to operate while replacing a blade if the redundant blade is active and failover does not occur.

- Cold swap procedure. Use this procedure to replace CP blades after removing power to the device.

Hot-swap procedure

Use this procedure to replace CP blades, one at a time, while the device power is on. The device continues to operate while replacing a blade if the redundant blade is active and failover does not occur. You can prevent failover by entering the **haDisable** command.

To replace both CP blades with power off, refer to the cold-swap replacement procedures.

Removing a blade

Use the following procedure to power down the device and remove CP blades. You can replace a single CP blade or both blades one at a time using the hot-swap procedure.

Procedure

1. Be sure to perform all steps under “Preparing for replacement” on page 125.
2. Power down the device.
3. Remove the chassis door.
4. Disconnect all cables from the CP blades.
5. Loosen the captive screws for each ejector handle on the blade using a #1 Phillips screwdriver. Loosening the screws initiates a hot-swap request and disconnects power from the blade. The spring-loaded captive screws will pop out from the slot .63 cm (.25 in.) when fully disengaged. Do not eject the blade using blade handles until screws disengage from slot and the power LED is off.
6. Grasp each ejector handle on blade and simultaneously pull the handles away from the blade to approximately 45 degrees. As you move the handles, you will hear connectors disengaging from the backplane connector and possibly a slight popping noise. This is normal and is due to the dense backplane. The blade will move out approximately 1.27 cm (.5 in.) from the slot when fully disengaged.
7. Slowly pull the blade from the slot. Do not support blade fully using injector handles after removal. As you slide out the blade, place one hand under blade for support. Be sure blade has cooled sufficiently to touch.

CAUTION:

To avoid damaging blade and chassis, do not push the blade into a slot or pull the blade from a slot using the ejector handles.

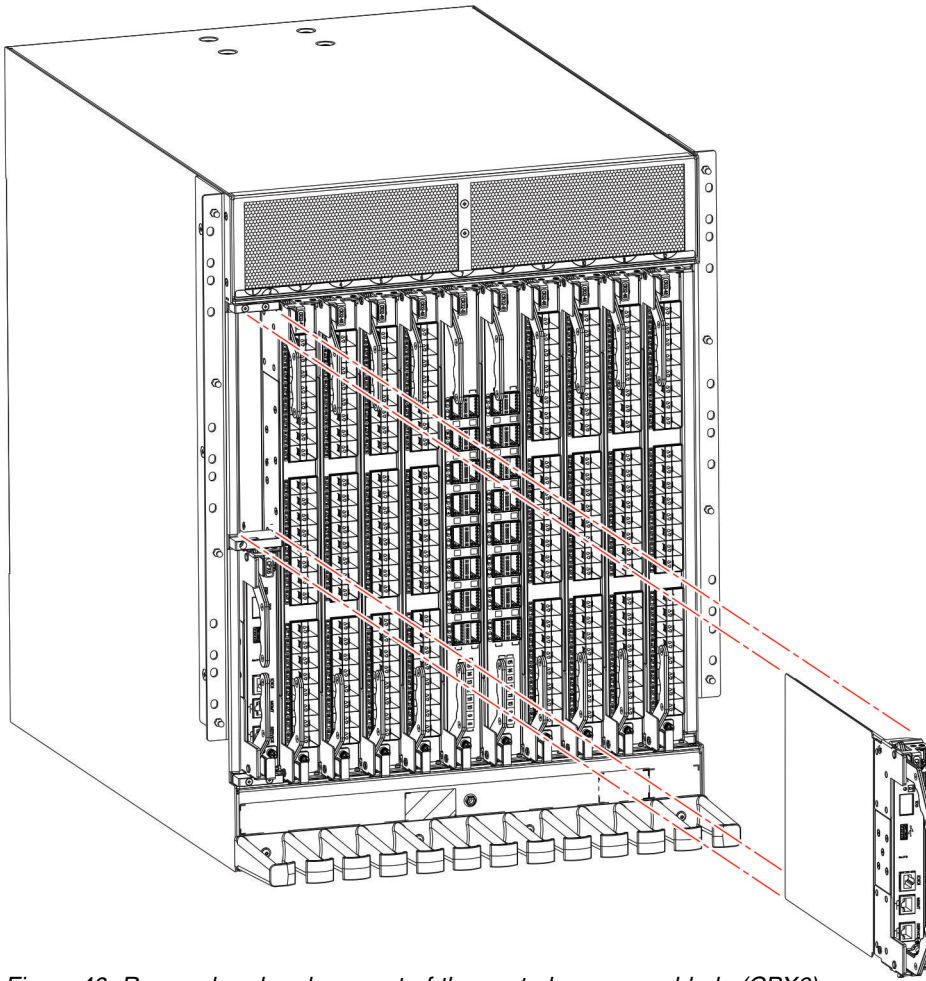

Figure 40. Removal and replacement of the control processor blade (CPX6)

8. If the blade is not being replaced by another blade, install a filler panel and reinstall the chassis door. The filler panel is required for proper chassis cooling. The door is required to meet EMI compliance.

Installing a blade

About this task

Note: Read all of the instructions for replacing the CP blade before beginning the procedure. Make sure that the same version of Fabric OS is installed on both CP blades. Using different versions is not supported and may cause malfunctioning. If the replacement CP blade has a different version of Fabric OS, bring both blades to the same firmware version. Once you have installed the replacement CP blade, determine the version of firmware on the replacement CP blade and upgrade it if necessary.

Complete the following steps to install a CP blade.

Procedure

1. If a protective sleeve is covering the blade connectors remove the sleeve.
2. Open the ejector handles completely to approximately 45 degrees. Orient the blade so that the handles are toward you and the flat metal side is facing down.
3. Follow these steps to insert the blade into the slot.

- a. Align the blade in the slot with the flat metal side of the blade at the bottom (blade power and status LEDs are on the left).
- b. Carefully slide the blade into the slot using your thumbs on the blade face. When the blade is about 2.54 cm (1 in.) from the chassis, you should feel resistance as the blade connectors meet the backplane connectors.

CAUTION:

To avoid damaging blade and chassis, do not push the blade into a slot or pull the blade from a slot using the ejector handles.

- c. Continue pushing with your thumbs until the ejectors move in towards the blade slightly indicating that the connectors are engaged.
 - d. Push the ejector handles fully in towards the blade simultaneously to seat it completely in the slot. As you move the handles, you will hear connectors engaging the backplane connector and possibly a slight popping noise. This is normal and is due to the dense backplane.
4. Tighten the captive screw for each ejector using a #1 Phillips screwdriver. As blade seats completely, amber blade status and green blade power LEDs illuminate.

Note: Be sure that captive screws are tightened. If not, high pressure from fan operation may unseat blade from chassis connectors.

5. Observe the blade power and status LEDs and verify the following:
 - a. The amber status LED on the blade illuminates until POST completes for the blade. The LED remains amber until the blade has gained sync with the active CP. This can take a few minutes to complete depending on the configuration. If the status LED remains amber for an extended period, the board may not be properly seated in the backplane or the board may be faulty.
 - b. The power LED on the port blade should displays a steady green. If it does not turn on, ensure that the blade is firmly seated and blade ejector screws are tightened.
6. Connect the cables to the new CP blade.
7. Remain logged in to the active CP and continue to “Verifying and synchronizing firmware on blades.”

Verifying and synchronizing firmware on blades

About this task

At this point, the active blade is up and running. The replacement blade is the standby blade. To verify that boot and POST are complete on a newly installed CP blade, that the CP blade has achieved failover redundancy, and that firmware levels are synchronized on the installed blades, perform the following steps.

Procedure

1. Enters **slotShow**. The command output shows the new CP blade as "enabled." If the standby CP is unresponsive, you can try unplugging the new CP blade, running **haDisable** on the active CP blade, and plugging the new CP blade back in. At that point, you can repeat step 1 to begin the verification process again.
2. Log into each CP blade and enter the **haShow** command to display the CP status. Verify the CP state, status, health, and that the HA state is synchronized. Remedy any issues before proceeding. For more information on **haShow** output, refer to the *Fabric OS Command Reference*.

3. Determine the firmware version of installed CP blades by entering **firmwareShow**. If the serial console on the replacement CP blade is connected, issue the **firmwareShow** command there. More information is available through the console.
4. If the firmware versions for both CP blades are the same, skip to “Completing the replacement” on page 135.
If the firmware version on the replacement (standby) blade does not match that on the active CP blade, a warning message appears with the results of the **firmwareshow** command.
WARNING: The local CP and remote CP have different versions of firmware, please
5. Bring the replacement blade firmware to the same firmware level as the active blade using one of the following procedures:
 - Run the **firmwaresync** command on the active CP blade to copy all firmware from the active CP blade to the standby CP blade.

Note: Using this command requires that existing telnet, secure telnet, or SSH sessions to the standby CP blade to be restarted.
 - Run the **firmwareDownload -s** command or **firmwaresync** command (if versions are compatible) to update firmware on the replacement blade to bring it up to the proper level.
6. Perform one of the following tasks to download firmware:
 - If you are using an FTP server to download the firmware, skip to the procedure for downloading firmware from an FTP server.
 - If you are using a USB device to download the firmware, skip to the procedure for downloading firmware from a USB device. If the firmware on the standby CP blade is more than one level down from the level on the active CP blade, you must have formatted USB devices for each of the versions you will need to upgrade.

For details on supported upgrade paths and steps to upgrade through multiple versions of Fabric OS, refer to the *Fabric OS Release Notes*, and the *Fabric OS Upgrade Guide*.

Downloading firmware from FTP server: About this task

For this task, determine the correct sequence of upgrading firmware versions to reach your target version.

Complete the following steps to download the firmware from an FTP server to the replacement blade.

Procedure

1. Log in to the standby CP blade as **admin**. If you need to know the IP address of the standby blade, run **ipaddrshow**.
You should remain logged in to the active CP blade in order to monitor it.
2. Run **firmwareDownload -s** to download the firmware to the replacement (standby) CP blade. The **-s** option also disables the autoreboot, so you will have to manually issue a reboot after the download finishes to initiate **firmwarecommit**. Enter all requested information (use default values).
3. When the download process finishes, run **firmwareDownloadStatus** to verify that the firmware has been updated. The command displays a running account of the progress of the **firmwareDownload** command (if it is still running) until

the command has completed. The final message is similar to the following and will appear with a date and time stamp.

```
Slot 1 (CP0, active): Firmwaredownload command has completed successfully.  
Use firmwaredownload to verify the firmware versions.
```

4. On the standby CP blade (the blade for which you just changed the firmware level), run **reboot**. The reboot of the standby CP will initiate a **firmwarecommit** to the secondary partition and log you out.

```
Chassis_1:admin> reboot  
Broadcast message from root (ttyS0) Fri Jun 17 14:49:45 2016...  
The system is going down for reboot NOW !!  
INIT: Switching to runlevel: 6  
INIT: Sending processes the TERM signal Chassis_1:admin> HAMu Heartbeat down, stop FSS  
Unmounting all f#exiting due to signal: 9, pending signals: 0x20000, 0x0  
ilecosystems.  
Please stand by while rebooting the system...  
Restarting system.  
The system is coming up, please wait...  
.  
.  
.  
Fri Jun 17 14:53:13 2016: Doing firmwarecommit now.  
Please wait ...  
Fri Jun 17 14:55:27 2016: Firmware commit completes successfully.  
Validating the filesystem ...  
Fri Jun 17 22:36:05 2016: Doing firmwarecommit now.  
Please wait ...  
Fri Jun 17 22:36:48 2016: Firmware commit completes successfully.  
2016/06/17-14:56:50, [SULB-1004], 908, SLOT 2 | CHASSIS, INFO,  
...Firmwarecommit has completed.  
2016/06/17-14:56:50, [SULB-1036], 909, SLOT 2 | CHASSIS, INFO,  
...The new Version: Fabric OS [version]  
2016/06/17-14:56:50, [SULB-1002], 910, SLOT 2 | CHASSIS, INFO,  
...Firmwaredownload command completed successfully.
```

5. Log back in to the standby CP blade and run **firmwareDownloadStatus** on the standby CP blade to validate a successful commit. This may take 10 minutes.
6. If you are upgrading through several levels of the Fabric OS, repeat step 2 through step 5 as often as necessary based on the path outlined in the preceding table. Otherwise, proceed to step 7.
7. Log out of the standby CP blade and log in to the active CP blade.
8. Proceed to the procedures for verifying operation of the new CP blade.

Downloading firmware from USB device:

About this task

For this task, determine the correct sequence of upgrading firmware versions to reach your target version.

This section assumes that the new firmware has already been copied onto the USB device. The folder structure on the USB device must be as follows in order to allow the device to be enabled:

- IBM>
 - config
 - firmware (Contains the specific release you are installing)
 - firmwareKey
 - support

Complete the following steps to download the firmware from a USB device to the replacement blade.

Procedure

1. Insert the USB device into the active CP blade.
2. Attach a serial cable from the PC to the active CP blade.

3. Log in to the active CP blade as **admin** if you are not still logged in and enter **usbStorage -e** to enable the USB device.
4. Remove the serial cable from the active CP blade and attach it to the standby CP blade and log in as **admin**.
5. Run **firmwareDownload -s** to download the firmware to the standby CP blade. Enter all requested information. The -s option disables the autoreboot, so you will have to manually issue a reboot after the download finishes to initiate firmwarecommit. Use all default values, except use USB [Y] so that USB will be used for downloading.
6. When the download process finishes, run **firmwareDownloadStatus** to verify that the firmware has been updated. The command displays a running account of the progress of the **firmwareDownload** command until the command has completed. The final message is similar to the following and will appear with a date and time stamp.

```
Slot 1 (CP0, active): Firmwaredownload command has completed successfully.
Use firmwareshow to verify the firmware versions.
```

7. Ensure that you are still logged in to the standby CP blade (the blade for which you just changed the firmware level) and type **reboot**. The reboot of the standby CP will initiate a **firmwarecommit** to the secondary partition and log you out.

```
Chassis_1: admin> reboot
Broadcast message from root (ttyS0) Fri Jun 17 14:49:45 2016...
The system is going down for reboot NOW !!
INIT: Switching to runlevel: 6
INIT: Sending processes the TERM signal Chassis_1:admin> HAMu Heartbeat down, stop FSS
Unmounting all ##exiting due to signal: 9, pending signals: 0x20000, 0x0
ilecosystems.
Please stand by while rebooting the system...
Restarting system.
The system is coming up, please wait...
.
.
.
Fri Jun 17 14:53:13 2016: Doing firmwarecommit now.
Please wait ...
Fri Jun 17 14:55:27 2016: Firmware commit completes successfully.
Validating the filesystem ...
Fri Jun 17 22:36:05 2016: Doing firmwarecommit now.
Please wait ...
Fri Jun 17 22:36:48 2016: Firmware commit completes successfully.
2016/06/17-14:56:50, [SULB-1004], 908, SLOT 2 | CHASSIS, INFO,
...Firmwarecommit has completed.
2010/06/17-14:56:50, [SULB-1036], 909, SLOT 2 | CHASSIS, INFO,
...The new Version: Fabric OS [version]
2010/06/17-14:56:50, [SULB-1002], 910, SLOT 2 | CHASSIS, INFO,
...Firmwaredownload command completed successfully.
```

Note: The time stamp on the co-CPU may not be in sync with the main CPU on the blade. This is not a cause for concern.

8. Log back in to the standby CP blade and enter **firmwareDownloadStatus** on the standby CP blade to validate a successful commit. This may take 10 minutes.
9. If you are upgrading through several levels of the Fabric OS, repeat step 5 through step 8 as often as necessary based on the path outlined in the preceding table. Otherwise, proceed to step 10.
10. Log out of the standby CP blade and log in to the active CP blade.
11. Proceed to the procedures to "Completing the replacement."

Cold-swap procedure

Use this procedure to replace both CP blades while the device power is off. You must power off the device to replace both CP blades. To replace a single blade, refer to the hot-swap replacement procedures.

Removing a blade

Use the following procedure to power down the device and remove CP blades. You can replace a single CP blade or both blades one at a time using the hot-swap procedure.

Procedure

1. Be sure to perform all steps under “Preparing for replacement” on page 125.
2. Power down the device.
3. Remove the chassis door.
4. Disconnect all cables from the CP blades.
5. Loosen the captive screws for each ejector handle on the blade using a #1 Phillips screwdriver. Loosening the screws initiates a hot-swap request and disconnects power from the blade. The spring-loaded captive screws will pop out from the slot .63 cm (.25 in.) when fully disengaged. Do not eject the blade using blade handles until screws disengage from slot and the power LED is off.
6. Grasp each ejector handle on blade and simultaneously pull the handles away from the blade to approximately 45 degrees. As you move the handles, you will hear connectors disengaging from the backplane connector and possibly a slight popping noise. This is normal and is due to the dense backplane. The blade will move out approximately 1.27 cm (.5 in.) from the slot when fully disengaged.
7. Slowly pull the blade from the slot. Do not support blade fully using injector handles after removal. As you slide out the blade, place one hand under blade for support. Be sure blade has cooled sufficiently to touch.

CAUTION:

To avoid damaging blade and chassis, do not push the blade into a slot or pull the blade from a slot using the ejector handles.

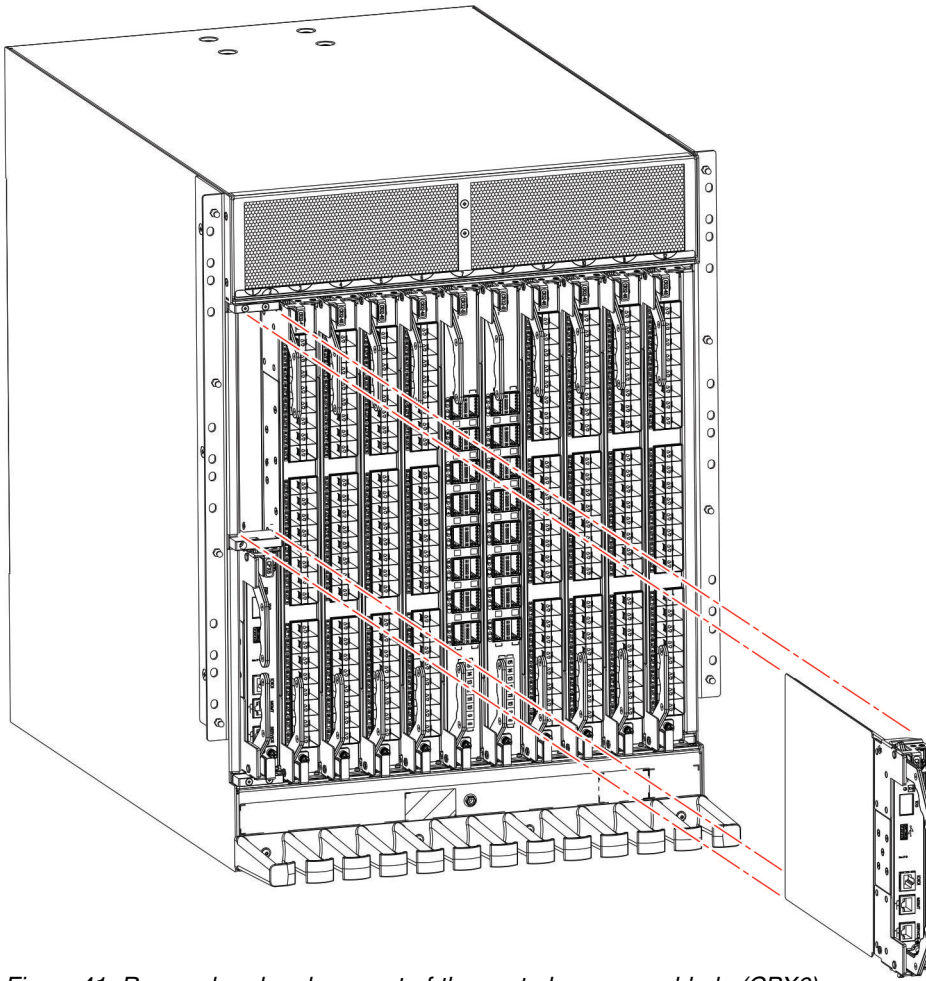

Figure 41. Removal and replacement of the control processor blade (CPX6)

8. If the blade is not being replaced by another blade, install a filler panel and reinstall the chassis door. The filler panel is required for proper chassis cooling. The door is required to meet EMI compliance.

Installing a blade

About this task

Use the following steps to install both CP blades when the device power is off (cold-swap procedure).

Procedure

1. Open the ejector handles completely to approximately 45 degrees. Orient the blade so that the handles are toward you and the flat metal side is facing down.
2. Follow these steps to insert each blade into the slot.
 - a. Align the blade in the slot with the flat metal side of the blade at the bottom (blade power and status LEDs are on the left).
 - b. Carefully slide the blade into the slot using your thumbs on the blade face. When the blade is about 2.54 cm (1 in.) from the chassis, you should feel resistance as the blade connectors meet the backplane connectors.

CAUTION:

To avoid damaging blade and chassis, do not push the blade into a slot or pull the blade from a slot using the ejector handles.

- c. Continue pushing with your thumbs until the ejectors move in towards the blade slightly indicating that the connectors are engaged.
 - d. Push the ejector handles fully in towards the blade to seat it completely in the slot. As you move the handles, you will hear connectors engaging the backplane connector and possibly a slight popping noise. This is normal and is due to the dense backplane.
3. Tighten the captive for each ejector using a #1 Phillips screwdriver.

Note: Be sure that captive screws are tightened. If not, high pressure from fan operation may unseat blade from chassis connectors.
 4. Power up the device.
 5. Connect the cables to the new CP blades.
 6. Enter **chassisDisable**.
 7. Enter **configDownload -vf** to download device virtual fabric data to the local system. The device reboots and partitions are restored.
 8. Enter **chassisDisable**.
 9. Enter **configDownload -map** to download port-to-area addressing mode configuration files to the local system.
 10. Power-cycle the chassis. The system recovers.
 11. Enter **chassisDisable**.
 12. Enter **configDownload -all** to download system configuration data, including chassis and switch configuration for all logical switches, to the local system. All the licenses, configurations, and FCIP tunnels are restored.
 13. Enter **reboot**. The device becomes fully functional with the new CP blades.
 14. Verify that each blade's power LED is green. If not, ensure that the CP blade has power and is firmly seated and that the ejectors are in the locked position.

Completing the replacement

About this task

Complete the following steps to complete the CP blade replacement procedure.

Procedure

1. Enter **haEnable** to re-enable HA on the active CP blade.

Note: The **haEnable** command will cause the standby CP blade to reboot. Wait until POST completes before moving to the next step. POST is complete when the status LED on the CP blade returns to a steady green state.

2. Enter **haShow** and verify that the command output includes "HA Enabled, Heartbeat Up". If it is not yet enabled, re-enter the command until you have verified that redundancy is achieved.

Note: The **haEnable** command will cause the standby CP blade to reboot.

```
Chassis_1:admin> hashow
Local CP (Slot 2, CP1) : Active
Remote CP (Slot 1, CP0) : Standby, Healthy
HA Enabled, Heartbeat Up, HA State Synchronized
```

3. Enter **firmwareShow** to verify that the firmware version has been updated and that the versions are the same on the two CP blades.

```
chassis:admin> firmwareshow -v
Slot NameApp1 Primary/Secondary VersionsStatus
-----
```

```
1CP0FOSv8.0.1STANDBY
v8.0.1
2CP1FOSv8.0.1ACTIVE *
v8.0.1
3SX6FOSv8.0.1
v8.0.1
4SX6FOSv8.0.1
v8.0.1
7SX6FOSv8.0.1
v8.0.1
8SX6FOSv8.0.1
v8.0.1
```

If you have one or more port or extension blades in the device, the Fabric OS automatically detects mismatches between the active CP firmware and the blade's firmware and triggers the auto-leveling process. This auto-leveling process automatically updates the application blade firmware to match the active CP blade. At the end of the auto-leveling process, the active CP and extension blades will run the same version of the firmware.

4. Enter the **chassisEnable** command to enable all user ports in the chassis and enable a virtual, fabric-aware chassis.
5. Replace the chassis door. The door is required to meet EMI compliance.
6. Pack the faulty CP blade in the packaging provided with the new CP blade, and contact the switch supplier to determine the return procedure.

Verifying blade operation

About this task

Perform the following tasks to verify operation of new blade:

Procedure

1. Check the LED indicators on the blade's front panel. For information on interpreting LED patterns, refer to "Interpreting control processor blade LEDs" on page 66.
2. Enter the following commands and note any error conditions:
 - **slotShow** - Displays the current data on each slot in the system, including blade type, blade ID, status, model name, and power usage.
 - **haShow** - Displays control processor (CP) status.
 - **tempShow** - Displays temperature reading of blades.
 - **sensorShow** - Displays temperature reading of blades with fan and power supply status.
 - **errDump** - Displays the system error log.
 - **errShow** - Displays error log messages one at a time.

Example

For output examples and additional information on Fabric OS commands, refer to "Using monitoring commands" on page 77 and the *Fabric OS Command Reference*.

For more information about error messages, refer to the *Fabric OS Message Reference*.

Chapter 10. WWN Cards

This chapter provides the following information:

- “WWN card overview”
- “Precautions specific to WWN cards” on page 138
- “WWN card fault indicators” on page 138
- “WWN card replacement task guide” on page 140
- “Time and items required for replacement” on page 140
- “Using the `wwnrecover` utility” on page 141
- “Preparing for WWN card replacement” on page 142
- “Hot-swap replacement” on page 143
- “Cold-swap replacement” on page 144
- “Removing the WWN card and bezel” on page 146
- “Configuring airflow direction on WWN cards” on page 147
- “Verifying WWN card operation” on page 149

WWN card overview

Two WWN cards are located behind the WWN bezel between the power supplies on the nonport side of the device. WWN 1 is located on the left side and WWN is located on the right side. The WWN cards store critical configuration data, such as WWN, IP addresses, part and serial numbers, and license IDs for the device.

Identical data must be maintained on each WWN card at all times so that if one card fails, the system can use the other card to provide valid system operation. To maintain data and ensure its integrity, the system audits both WWN cards one hour after the first system boot-up, every 24 hours after boot-up, and any time a WWN card is inserted to compare the critical data.

If a data mismatch is detected during the audit, messages in the RASlog will provide a summary of all errors detected and prompt you through a data recovery process. The `wwnrecover` utility permits a recovery of WWN card data in the event of corruption. The data recovery mechanism may vary depending on the error encountered and the data being compared. Problems such as a mismatch between license IDs cannot be fixed with `wwnrecover`, and the output will direct you to call Technical Support. For other problems, running `wwnrecover` can pinpoint the problem and, in some cases, permit you to fix it. Mismatched data can be resolved, and corrupt data can sometimes be recovered. For more information on the `wwnrecover` utility, refer to “Using the `wwnrecover` utility” on page 141.

Note: The device will operate with one WWN card, but will be in degraded condition. If you have removed a card, be sure to replace as soon as possible.

WWN card location and numbering

WWN card are located behind the WWN bezel on the nonport side of the device between the power supplies. The bezel must be removed to access the card trays. The following figure illustrates WWN card location and numbering.

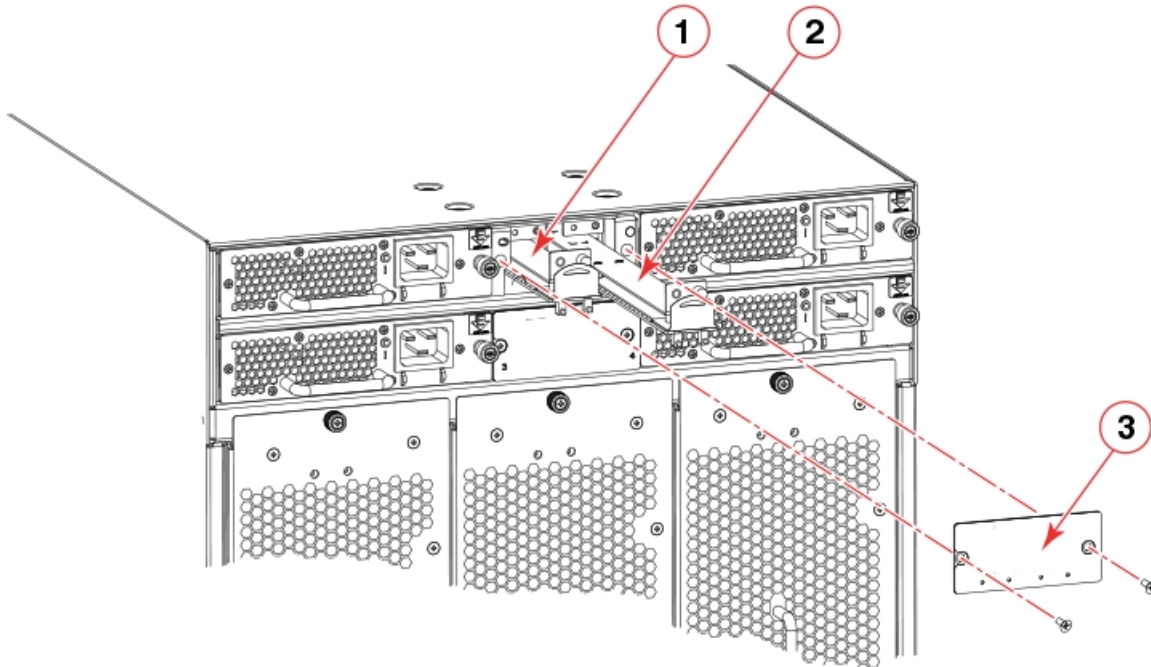

Figure 42. WWN card location and numbering

- 1 - WWN card 1
- 2 - WWN card 2
- 3 - WWN card bezel

Precautions specific to WWN cards

Observe the following precautions for these cards:

- Wear an appropriately grounded ESD wrist strap when handling and installing device blades and cards. Follow electrostatic discharge (ESD) precautions. Wear a wrist grounding strap connected to chassis ground (if the chassis is plugged in) or a bench ground.
- The device will operate with one WWN card, but will be in degraded condition. If you have removed a card, be sure to replace as soon as possible.

Note: Do not use steps in the WWN card and WWN card bezel removal procedures to disable logical switches and power down the device.



CAUTION:

For safety reasons, the ESD wrist strap should contain a series 1 megaohm resistor.



CAUTION:

Static electricity can damage the chassis and other electronic devices. To avoid damage, keep static-sensitive devices in their static-protective packages until you are ready to install them.

WWN card fault indicators

Before replacing a WWN card, verify that the replacement is necessary. Any of the following events can indicate that cards require replacement:

- RASlog messages may occur during periodic WWN card audit routines alerting you of data or license mismatches between WWN cards and other errors. Some of these messages may direct you to contact technical support or to run the **wwnrecover** command. You can use this command to further verify or to fix problems. If an EM-1220 or EM-1222 error message occurs due to WWN card data corruption or data mis-matches across WWN cards, data recovery may be possible using this command. For more information on using **wwnrecover**, refer to “Using the wwnrecover utility” on page 141. If recovery is not possible, command output will direct you to replace the affected card(s).
- Status LEDs on the WWN bezel do not reflect the actual status of the WWN cards or indicate a problem. For information on interpreting LED patterns, refer to “Interpreting WWN card LEDs” on page 70. Note that the LED patterns may temporarily change during POST and other diagnostic tests.
- Problems viewing or modifying the data stored on the WWN card.
- Error messages regarding WWN units in **chassisshow** output.

Error messages that may indicate problems with a WWN card are summarized in the following table.

Table 18. Messages that may indicate WWN card failure

Type of message	Sample error message
WWN unit fails its field-replaceable unit (FRU) header access.	0x24c (fabos): Switch: switchname, error EM-I2C_TIMEOUT, 2, WWN 1 I2C timed out: state 0x4
WWN unit fails to power on.	<timestamp>, [EM-1004], <sequence-number>, CRITICAL, <system-name>, WWN # failed to power on or <timestamp>, [EM-1043], <sequence-number>, WARNING, <system-name>, Can't power <FRU Id> <state (on or off)>.
WWN unit is being faulted.	0x24c (fabos): Switch: switchname, Critical EM-WWN_UNKNOWN, 1, Unknown WWN #2 is being faulted or <timestamp>, [EM-1003], 40, SLOT 7 FFDC CHASSIS, CRITICAL, Chassis, WWN 2 has unknown hardware identifier: FRU faulted or <timestamp>, [EM-1034], <sequence-number>, ERROR, <system-name>, WWN # set to faulty, rc=<return code>
WWN unit is not present or is not accessible.	0x24c (fabos): Switch: switchname, Error EM-WWN_ABSENT, 2, WWN #1 not present or <timestamp>, [EM-1036], <sequence-number>, WARNING, <system-name>, <FRU Id> is not accessible.
Writing to the FRU history log (hilSetFruHistory) has failed.	0x24c (fabos): Switch: switchname, Error EM-HIL_FAIL, 2, HIL Error: hilSetFruHistory failed, rc=-3 for SLOT 3

WWN card replacement task guide

This section contains a guide to more complete, detailed steps in this section for installing or replacing WWN cards when the device is running (hot swap) or must be powered off (cold swap). References are provided to the more detailed WWN removal and installation steps for further information.

Replacing WWN cards (hot-swap)

Use this procedure to replace WWN cards with system power on. You can use this procedure to replace one WWN card assembly at a time while power is on. To replace both cards, follow all steps for one card, and then repeat the same steps to replace the other card assembly.

1. Save settings and system data and order replacement WWN card(s) by following all steps under “Preparing for WWN card replacement” on page 142.
2. Replace a card by following all steps under “Hot-swap replacement” on page 143. Repeat these steps to replace the second WWN card if necessary.
3. If RASlog messages indicate a mismatch between fan and system airflow direction, follow steps under “Configuring airflow direction on WWN cards” on page 147.
4. Verify WWN card operation using steps under “Verifying WWN card operation” on page 149.

Replacing WWN cards (cold-swap)

Use this procedure to replace WWN cards with system power off. You can use this procedure to replace one or both WWN cards.

1. Save settings and system data and order replacement WWN card(s) by following all steps under “Preparing for WWN card replacement” on page 142.
2. Replace card(s) by following all steps under “Cold-swap replacement” on page 144.
3. If RASlog messages indicate a mismatch between fan and system airflow direction, follow steps under “Configuring airflow direction on WWN cards” on page 147.
4. Verify WWN card operation using steps under “Verifying WWN card operation” on page 149.

Time and items required for replacement

If there is a need to replace one or both WWN cards, allow approximately 20 minutes. Refer to “Using the wwnrecover utility” on page 141 and “WWN card fault indicators” on page 138 before replacement.

The following items are needed to replace the WWN cards:

- Electrostatic discharge (ESD) grounding strap
- #1 Phillips screwdriver
- Workstation computer

Using the wwnrecover utility

The **wwnrecover** utility permits a recovery of WWN card data in the event of corruption. Recovery is not possible if hardware issues prevent access to either WWN card or if the primary and backup copy of the license ID on either card is corrupted.

Identical data must be maintained on each WWN card at all times so that if one card fails, the system can use the other card to provide valid system operation. To maintain data and ensure its integrity, the system audits both WWN cards one hour after the first system boot-up, every 24 hours after boot-up, and any time a WWN card is inserted to compare the critical data.

If a data mismatch is detected during the audit, messages in the RASlog will provide a summary of all errors detected and prompt you through a data recovery process. The data recovery mechanism may vary depending on the error encountered and the data being compared. Problems such as a mismatch between license IDs cannot be fixed with **wwnrecover**, and the output will direct you to call Technical Support. For other problems, running **wwnrecover** can pinpoint the problem and, in some cases, permit you to fix it. Mismatched data can be resolved, and corrupt data can sometimes be recovered.

The following table lists RASlog messages that can occur during the WWN card audit routine.

Table 19. RASlog messages from WWN card audit

Error message	Issue
[EM-1220]...M1, ERROR ... A problem was found on one or both CID cards (x), please run the wwnrecover tool to get more information and recovery options.	Some kind of error or mismatch has been detected in the WWN card audit.
[EM-1221], ... M1, INFO, ... A WWN card has been inserted, a WWN verification audit will be run to detect any mismatches or other problems.	A second WWN card is enabled and the WWN card audit will be run. If an error is detected during the audit, EM-1220 and EM-1222 messages are generated.
[HIL-1650], CHASSIS, ERROR...Unable to detect WWN card in chassis. Access to WWN halted...	WWN card has been removed from the device. Replace as soon as possible since system is in degraded state.
[EM-1222], ... M1, WARNING, ... A WWN card access problem has been encountered, please run the wwnrecover tool to get more information and recovery options.	An error is detected during normal access to the WWN cards; typically, one of the cards is corrupted or inaccessible.
Recovery is not possible. Please contact Technical Support for replacement of the corrupted or inaccessible WWN(s).	The license ID on the two WWN cards do not match.

The **wwnrecover** utility must be used to maintain data integrity when replacing one or both WWN cards using instructions in the WWN card removal and replacement section. To run **wwnrecover**, log in as admin and enter the following command:

```
switch:admin# wwnrecover
```

For more information on **wwnrecover** and command syntax, refer to the *Fabric OS Command Reference*.

Preparing for WWN card replacement

About this task

If the WWN cards require replacement, complete the following steps. Follow electrostatic discharge (ESD) precautions.

Procedure

1. Open a Telnet session to the device and log in to the active CP blade as admin. The default password is "password".
2. Verify that you are logged in to the active CP blade. Run the **haShow** command to determine the active CP blade.
3. Run the **supportSave** command on the active CP blade to capture all settings. These settings will be referenced to verify the settings have been correctly programmed after WWN replacement.
4. Run the following commands on the device before replacing the cards so that the data can be verified after the replacement:
 - **licenseidshow**
 - **ipaddrshow**
 - **switchname**
 - **chassisname**
 - **wncardshow ipdata**
 - **chassisshow** (look at the WWN and chassis information at the bottom)
 - **ficonshow switchrnid** (FICON/mainframe environments only)
 - **configupload -all**
 - **configupload -vf**

The factory serial number and the sequence number in the following output from the **chassisShow** command should match. In the **ficonshow switchrnid** output, a sequence number indicates the logical switch number, if virtual fabrics is enabled:

```
switch:FID128:admin> chassisshow
<output truncated>
WWN Unit: 1
System AirFlow:      Non-portside Intake
Header Version:      2
Power Consume Factor: -1W
Factory Part Num:    60-1003194-02
Factory Serial Num:  DZH0331L039
Manufacture:         Day: 3 Month: 10 Year: 15
Update:              Day: 0 Month: 0 Year: 0
Time Alive:          24 days
Time Awake:          0 days
```

```
WWN Unit: 2
System AirFlow:      Non-portside Intake
Header Version:      2
Power Consume Factor: -1W
Factory Part Num:    60-1003194-02
Factory Serial Num:  DZH0331L032
Manufacture:         Day: 3 Month: 10 Year: 15
Update:              Day: 0 Month: 0 Year: 0
Time Alive:          24 days
Time Awake:          0 days
```

```
Chassis Factory Serial Num: AFY2530G00S
```

```

switch:admin> ficonshow switchrnid
{
  {Switch WWN          Flag Parm
  10:00:00:05:1e:95:b1:00 0x00 0x200a00
  Type number:         SLKWRM
  Model number:        SAN768B
  Manufacturer:        BRD
  Plant of Manufacture: CA
  Sequence Number:  0AFX2533G001
  tag:                 b6ff
}

```

5. Contact IBM Support for replacement of WWN cards. IBM Support will request the partner or OEM to send WWN cards from FRU inventory to the nearest IBM Support office to be reprogrammed. IBM Support will require the **Supportsave** data taken in the previous step so that the replacement cards can be reprogrammed prior to shipping to the partner or your site. If support has determined that both WWN cards need replaced, you must replace both WWN cards as a matched pair.

Hot-swap replacement

You may replace one WWN card assembly at a time with the system powered on using the following steps to avoid interruption of system operation.

About this task

Use this procedure if Customer Support has determined that a WWN card needs replaced and you have received replacement cards. These procedures require that you use the **wwnrecover** utility. For more information on this utility, refer to “Using the wwnrecover utility” on page 141.

You can use this procedure to replace one WWN card assembly at a time while power is on. Follow all steps for one card, and then repeat the same steps to replace the other card assembly. To replace both WWN card assemblies simultaneously, use procedures under “Cold-swap replacement” on page 144.

Procedure

1. Remove the defective WWN card assembly using procedures under “Removing the WWN card and bezel” on page 146. Removing a WWN card assembly will result in RASlog messages indicating that a WWN card cannot be detected. Since the system will be in a degraded state, replace the WWN card as soon as possible.
2. Install the replacement WWN card assembly into the empty slot using the following steps:
 - a. Holding the card assembly by its edges with both hands along its length, slide it into the chassis slot.
 - b. Push with your thumb on the end of assembly to fully seat into the backplane connector.
 - c. Use a Phillips screwdriver to tighten the captive screw and secure the card assembly to the chassis.

Note: Be sure that captive screws are tightened. If not, high pressure from fan operation may unseat cards from chassis connectors.

3. Verify that the WWN card is correctly connected by noting if the LEDs on the card reflects the status of the components.

4. Address any issues flagged by any RASlog EM-1220 and EM-1222 messages that display for the new card before proceeding.

Note: Issues relating to data recovery on new WWN cards must be resolved at this point before proceeding to avoid invalid WWN data, errors, and operating problems. If EM-1220 messages indicate that IP addresses on installed WWN cards do not match, follow instructions in the message to recover the IP address so that both cards use the same address.

5. Determine the active CP blade by entering the **haShow** command.
6. On the active CP blade, run the **wwnrecover** command and specify the WWN card that you replaced (WWN 2 or WWN 1) when prompted.
7. If **wwnrecover** messages prompt for a system reboot, reboot both CP blades to ensure the system is running with valid WWN card data.
8. Enter the **hafailover** command to force failover so that the standby CP blade becomes the active CP blade. This command is necessary so that the correct IP address for the new card displays for the **ipaddrshow** command. For more information on these commands, refer to the *Fabric OS Command Reference*.
9. Verify the new card settings by running the following commands and comparing the output with the original **supportsave** data:
 - **licenseidshow**
 - **ipaddrshow**
 - **switchname**
 - **chassisname**
 - **wwncardshow ipdata**
 - **chassisshow** (look at the WWN and Chassis information at the bottom)
10. If replacing the second WWN card, repeat the previous steps in this procedure for the other card.
11. Install the WWN bezel on the chassis.
 - a. Orient the bezel on the chassis.
 - b. Insert and tighten both screws using a Phillips screwdriver.
12. Pack faulty WWN cards in the packaging provided with the replacement cards, and return them to Support for failure analysis (FA).

Cold-swap replacement

About this task

Use this procedure When you can interrupt system operation and replace one or both WWN cards with the system powered down. You can replace one WWN card or both WWN cards, one at a time, with system power on using steps under "Hot-swap replacement" on page 143.

Note: Be aware that if replacing both WWN cards, the IP addresses on the new WWN cards will be in effect when the device powers up. If these IP addresses are different from the previous cards, then you will not be able to establish ssh or other sessions that use the previous IP addresses. You can change IP addresses on the new cards using the **ipaddrset** command.

Procedure

1. Unpack the replacement WWN card assembly and save the packaging for the faulty WWN card(s). The WWN card assemblies are labeled #1 for the left slot and #2 for the right slot.
2. Perform the following steps.
 - a. Log in to the device and execute the **switchcfgpersistentdisable** command on the main switch and other logical switches. The **switchcfgpersistentdisable** command disables the switches, and ensures they remain disabled after the power is cycled. This allows you to check all the settings so that you can verify the settings before placing the device back into production.

```
switch:admin> switchcfgpersistentdisable
Switch's persistent state set to 'disabled'
```

If there are other logical switches on your chassis, use the **setcontext** command to connect to all the other switches and then run **switchcfgpersistentdisable** on these switches as well.
3. Enter the **sysShutdown** command. When command output indicates that the device has completed shut-down, remove power cords from all power supply assemblies.
4. Remove defective WWN card assemblies using steps under “Removing the WWN card and bezel” on page 146, and then continue with step 5.

Note: There are two WWN card assemblies located behind the WWN bezel. As you are facing the bezel, WWN 1 is located on the left side, and WWN 2 is on the right.

5. Install replacement WWN card assemblies into the empty slot using the following steps:
 - a. Holding the card assembly by its edges with both hands along its length, slide it into the device slot.
 - b. Push with your thumb on the end of assembly to fully seat into the backplane connector.
 - c. Use a #1 Phillips screwdriver to tighten the captive screw and secure the card assembly to the chassis.

Note: Be sure that captive screws are tightened. If not, high pressure from fan operation may unseat cards from chassis connectors.

6. Power on the device and wait for five minutes for the device to boot.
7. Verify that new WWN cards are correctly connected by checking LED function. For details on LED operation, refer to “Interpreting WWN card LEDs” on page 70.

Note: The LEDs may take up to two minutes after WWN card installation to begin functioning.

8. Resolve any issues flagged by RASlog EM-1220 and EM-1222 messages that display for the new card(s) before proceeding.

Note: Issues relating to data recovery on new WWN cards must be resolved at this point before proceeding to avoid invalid WWN data, errors, and operating problems.

9. Determine the active CP blade by entering the **haShow** command.

10. On the active CP blade, run the **wwnrecover** command and specify WWN 2 card for recovery when prompted in **wwnrecover** output messages. Refer to “Using the wwnrecover utility” on page 141 for more information on this command.
11. If **wwnrecover** messages prompt for a system reboot, reboot both CP blades to ensure the system is running with valid WWN card data.
12. Verify the new card settings by running the following commands and comparing the output with the original **supportsave** data:
 - **licenseidshow**
 - **ipaddrshow**
 - **switchname**
 - **chassisname**
 - **wwncardshow ipdata**
 - **chassisshow** (look at the WWN and chassis information at the bottom)
13. Run the **switchcfgpersistentenable** command to persistently enable each logical switch, that was disabled before removing the WWN card(s):

```
switch:FID128:root> switchcfgpersistentenable
Switch's persistent state set to 'enabled'
```
14. Install the WWN bezel on the chassis.
 - a. Orient the bezel on the chassis.
 - b. Insert and tighten both screws using a Phillips screwdriver.
15. Pack faulty WWN card assemblies in the packaging provided with the replacement cards, and return them to Support for failure analysis (FA).

Removing the WWN card and bezel

About this task

Two WWN cards located behind the WWN bezel. As you are facing the bezel on the non-port-side of the device, WWN 1 is located on the left side, and WWN 2 is on the right. When cards have been determined faulty and the replacement WWN cards have been received, complete the following steps to remove the bezel and faulty WWN cards.

Note: Unless the device is powered down and not operational, do not perform these steps without first performing procedures under either “Hot-swap replacement” on page 143 or “Cold-swap replacement” on page 144.

Procedure

1. Remove the two screws from the WWN bezel on the back of the device using a Phillips screwdriver. Pull the bezel away from the chassis and set it aside. The ends of both WWN card assemblies with pull tabs are now visible.
2. Unscrew the captive screw for the WWN card assembly using a Phillips screwdriver until the assembly releases from chassis.
3. Grasp the pull tab for a WWN card assembly and gently pull to release the assembly from backplane connector. Carefully slide the card assembly out from the chassis slot. Use both hands to support the card assembly along its length as you remove it from the slot.

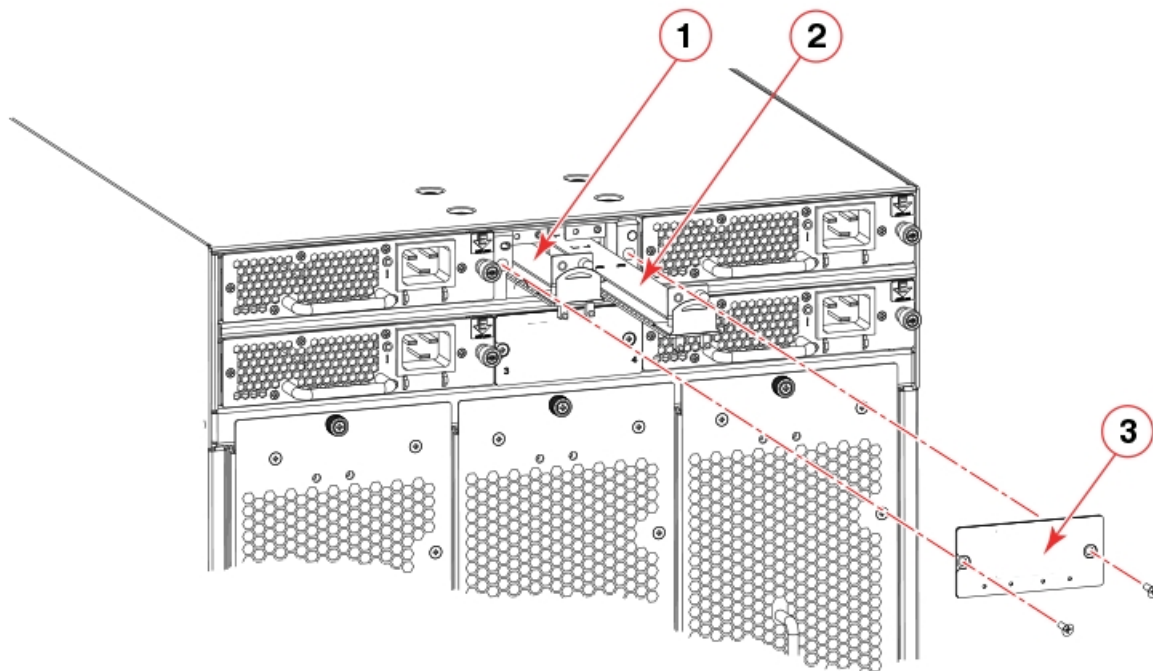

Figure 43. Removing and installing WWN cards

- 1 - WWN card 1
 - 2 - WWN card 2
 - 3 - WWN card bezel
4. Depending on the WWN card assembly removed, label the assembly with #1 for the left-side assembly and #2 for the right-side assembly for future reference.
 5. Set the WWN card assembly on a static-free surface, such as a grounding pad.

Configuring airflow direction on WWN cards

About this task

All fan and power supply assemblies installed in the chassis must provide the same airflow direction, either nonport-side intake (NPI) or nonport-side exhaust (NPE). In a factory-configured system, this airflow direction will match the airflow direction configured for the chassis on the installed WWN cards.

A mismatch of between system and fan and power supply airflow direction may occur when installing new WWN cards into an existing chassis with fan and power supply assemblies already installed or when installing fan and power supply assemblies into a replacement chassis. Replacement chassis are shipped with new WWN cards installed, and airflow direction is not configured on these cards.

The system detects airflow direction of the chassis at system boot based on airflow direction of installed power supply and fan assemblies. Normally, if there is a mismatch between airflow direction set on WWN cards and airflow direction of the installed fan and power supply assemblies, the system will automatically configure the established airflow direction on the WWN cards, provided *all* installed fan and power supply assemblies have the same airflow direction. RASLOG messages such as the following will occur during this automatic configuration:

```
...[HIL-1630], 449, SLOT 1 CHASSIS, INFO, chassis1, Auto-configuring
system airflow direction to Non-portside Exhaust
```

```
[HIL-1630], 449, SLOT 1 CHASSIS, INFO, chassis1, Auto-configuring
system airflow direction to Non-portside Intake
```

If airflow direction for power supply and fan assemblies does not match, WWN cards will not automatically reconfigure and the fan or power supply assembly with mismatched airflow will fault. In this case, you must replace fan or power supply assemblies to achieve matching airflow direction for all, and then reboot the system.

The following procedure is provided if you need to manually synchronize airflow direction on WWN cards with airflow direction of installed fan and power supply assemblies.

Note: Changing chassis airflow is only supported to synchronize established airflow direction of installed fan and power supply assemblies with airflow direction configured on WWN cards. Changing airflow direction from NPI to NPE or NPE to NPI is not supported in a customer environment.

Procedure

1. Enter **chassisShow** to display airflow direction programmed in WWN cards and airflow direction of installed fan and power supply FRUs. Airflow direction of fans and power supplies displays as "Fan Direction" under each fan or power supply unit. System airflow direction displays as "System Airflow" under the WWN card unit. The following example shows mismatch of system airflow and airflow direction in installed fan and power supply as the WWN units should indicate "Non-portside Intake."

```
POWER SUPPLY Unit: 1
Power Source:          AC
Fan Direction:         Non-portside Intake
...
FAN Unit: 2
Fan Direction:         Non-portside Intake
...
WWN Unit: 1
System AirFlow:       Non-portside Exhaust
...
WWN Unit: 2
System AirFlow:       Non-portside Exhaust
```

2. To reconfigure airflow direction on installed WWN cards, enter **wnnrecover**.

```
sw0:admin> wnnrecover
WWN 1 and/or WWN 2 system airflow direction mismatches with the
installed fan FRU's airflow direction.
```

```
WWN Non-Critical Seeprom Problem Details
```

```
WWN 1 system airflow direction mismatches with installed Fan FRU's
airflow direction!!!!
WWN 2 system airflow direction mismatches with installed Fan FRU's
airflow direction!!!!
```

```
Recovery Options
```

```
0. Exit
```

```
1. Copy Airflow direction from Fan FRU to both WWN cards
```

3. Enter **1** when prompted for a recover option to copy airflow direction from the fan to both WWN cards.

Enter Selection > 1
WWN Airflow direction recovery complete.

Please reboot the system.

4. Reboot the system.

Verifying WWN card operation

About this task

Perform the following tasks to verify operation of the WWN cards:

Procedure

1. Check the LED indicators on the WWN card bezel, located between the power supplies on the nonport side of the device. The LED patterns may temporarily change during POST and other diagnostic tests. For information on interpreting LED patterns, refer to “Interpreting WWN card LEDs” on page 70.
2. Enter the **errDump** command. This displays the system error log.

Example

For output examples and additional information on Fabric OS commands, refer to “Using monitoring commands” on page 77 and the *Fabric OS Command Reference*.

For more information about error messages, refer to the *Fabric OS Message Reference*.

Chapter 11. Power Supply Assemblies

This chapter provides the following information:

- “Power supply assembly overview”
- “Precautions specific to power supply assembly” on page 154
- “Power supply assembly fault indicators” on page 155
- “Power supply assembly task guide” on page 155
- “Time and items required” on page 156
- “Removing a power supply” on page 156
- “Installing a power supply” on page 158
- “Verifying power supply operation” on page 158

Power supply assembly overview

Power supplies can be removed and replaced without special tools. If replacing one power supply, the device can continue operating during replacement if procedures are followed in this guide.

This device supports the following power supply assemblies. All power supplies installed in the device must be of the same type and match the airflow of installed fan assemblies.

- Power supply model supporting nonport-side air intake (NPI) provides 1450 W (100-120 VAC) and 2870 W (200-240 VAC). This assembly has two fans that move the air from the nonport side to the port side of the device.
- Power supply model supporting nonport-side air exhaust (NPE) provides 1450 W (100-120 VAC) and 2870 W (200-240 VAC). This assembly has two fans that move the air from the port side to the nonport side of the device.

The following figure illustrates power supply assembly components.

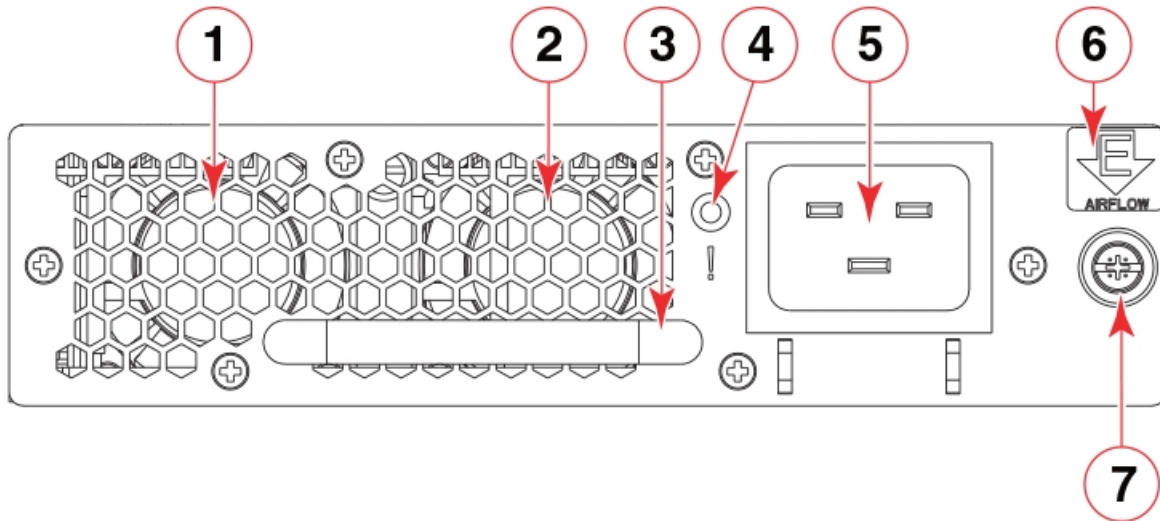

Figure 44. AC power supply assembly

1 - Fan 1

- 2 - Fan 2
- 3 - Handle
- 4 - Status LED
- 5 - AC power cable receptacle
- 6 - Airflow label
- 7 - Captive screw

The SAN512B-6 can have three or four power supplies installed, depending on the quantity ordered. Use of the high-voltage line (200 to 240 VAC) is highly recommended because of better power conversion efficiency. Refer to "Power Supply Requirements" in "Product specifications," on page 195 for minimum power supplies required for AC low and high voltage line operation, redundancy in case of power supply failure, and other specifications.

Redundant AC primary power connections ensure high availability. Each power supply has its own connector. If four power supplies are installed, four primary power connections are required for the SAN512B-6 for optimum efficiency and redundancy.

Fan and power supply airflow

All fans and power supply FRUs installed in this device must have either NPI (nonport-side intake) or NPE (nonport-side exhaust) airflow. You must order a replacement FRU with the same part number (P/N) as the FRU being replaced to provide the same airflow. The manufacturing P/N, located on the top of the FRU, contains either NPI or NPE. If a mismatched power source or fan assembly is installed by mistake, a RASlog message occurs indicating that a mismatch in fan or power supply airflow has occurred and the FRU is faulted.

Note: If airflow direction for a power supply assembly does not match the chassis airflow direction as stored on WWN cards, the power supply will have a "fault" status. However, LED operation for the power supply will not indicate a fault. If airflow direction for a fan assembly does not match the chassis airflow direction, the fan LED will indicate a fault condition.

You can use external labels as a guide. The power supply and fan assemblies are labeled with a green "E" or orange "I" airflow symbol on the faceplate. The symbol also appears on the top of the FRU. All fans and power supplies in a chassis must have the same label affixed to guarantee airflow direction is consistent.



Figure 45. Airflow labels

The orange I symbol indicates an intake FRU. This unit pulls air in from the nonport side of the device and exhausts it out the port side. This is called back-to-front airflow or intake airflow. This symbol should appear on FRUs with part numbers that contain an **NPI**.

The green E symbol indicates an exhaust FRU. This unit pulls air in from the port side of the device and exhausts it out the nonport side. This is called front-to-back airflow or exhaust airflow. This symbol should appear on FRUs with part numbers that contain an **NPE**.

Ensure airflow direction of power supply and fan assemblies match airflow direction of the chassis configured on installed WWN cards. If power supply or fan air flow direction does not match, the FRU will fault. Faulty fans can cause increase in temperature.

Airflow direction can be verified by entering the **chassisShow** command. Following is an example from command output indicating mis-matching airflow. WWN units should indicate "Non-portside Intake".

```
POWER SUPPLY Unit: 1
Power Source:      AC
Fan Direction:     Non-portside Intake
...
FAN Unit: 2
Fan Direction:     Non-portside Intake
...
WWN Unit: 1
System AirFlow:   Non-portside Exhaust
...
WWN Unit: 2
System AirFlow:   Non-portside Exhaust
```

Note: Ensure that captive screws securing the fan and power supply assemblies are tightened. If they are not, air pressure inside chassis may unseat these FRUs from chassis connectors.

Power supply assembly numbering

The following figure illustrates the location and number identification of power supply assemblies in the chassis.

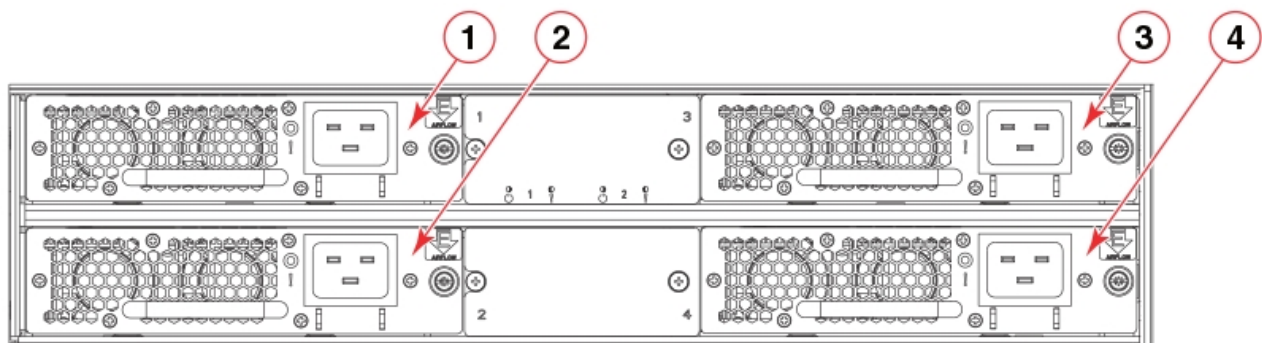

Figure 46. Power supply assembly numbering

- 1 - Power supply 1
- 2 - Power supply 2
- 3 - Power supply 3

Precautions specific to power supply assembly

Observe the following precautions when replacing the power supply assembly.

Note: Depending on the blade configuration of the device and the number of power supplies installed, the device may be able to continue operating while replacing a power supply. Refer to "Power Supply Requirements" in "Product specifications," on page 195 for minimum power supplies required for AC low and high voltage line operation, redundancy in case of power supply failure, and other specifications. If there is insufficient power, the device will start powering down blades until the power demand can be met.

Note: A device with slots for eight port blades can have up to four power supplies installed. If you are adding additional power supplies, you can use the procedures in this section under "Installing a power supply" on page 158 to install the new power supplies. Be sure to follow steps on those procedures to enable sending notifications if the additional power supplies should fail.

Note: Make sure that captive screws securing power supply assemblies to chassis are tightened. If not, high pressure from fans operation may unseat power supply assemblies from chassis connectors.



DANGER

Make sure that the power source circuits are properly grounded, then use the power cord supplied with the device to connect it to the power source.



CAUTION:

Use a separate branch circuit for each power cord, which provides redundancy in case one of the circuits fails.



DANGER

If the installation requires a different power cord than the one supplied with the device, make sure you use a power cord displaying the mark of the safety agency that defines the regulations for power cords in your country. The mark is your assurance that the power cord can be used safely with the device.



DANGER

High Touch Current. Earth connection essential before connecting supply.

Power supply assembly fault indicators

Use one of the following methods to determine if a power supply is faulty:

- Check the power supply status LED.
 - The LED may take up to 10 seconds to illuminate. If LED does not illuminate, the power supply has no incoming power. Check if power supply is properly seated in backplane connector. Check power source to power cord.
 - If LED is flashing green, the power supply may be faulty.

For more information on LED operation, refer to “Interpreting power supply LEDs” on page 71.

- Enter **psShow**. If status of power supply displays absent or faulty, check if power supply assembly is seated in chassis. If it is, power supply could be faulty.
- Enter **sensorShow** to determine if a power supply is running above average temperatures of other installed power supplies.
- Enter **errDump** to display the system error log. Refer to the *Fabric OS Message Reference* for more information on the messages in this log.

Refer to “Using monitoring commands” on page 77 and the *Fabric OS Command Reference* for output examples and additional information on Fabric OS commands.

For more information about error messages, refer to the *Fabric OS Message Reference*.

Power supply assembly task guide

This section contains a guide to more complete, detailed steps in this section for installing or replacing power supply assemblies when the device is running (hot swap) or must be powered off (cold swap). References are provided to the more detailed removal and installation steps for further information.

Note: Depending on the blade configuration of the device and the number of power supplies installed, the device may be able to continue operating while replacing a power supply. Refer to “Power Supply Requirements” in “Product specifications,” on page 195 for minimum power supplies required for AC low and high voltage line operation, redundancy in case of power supply failure, and other specifications. If there is insufficient power, the device will start powering down blades until the power demand can be met.

Installing additional power supply (hot-install)

If your device is up and running, has empty slots for power supplies, and you want to install additional power supplies, complete the following steps.

1. Remove filler panel from empty power supply assembly slot.
2. Insert the new power supply assembly.
3. Plug power cord into the new power supply assembly from power source.
4. Verify power supply assembly status LED.

Replacing power supply assembly (hot-swap)

If your device is up and running, but a power supply has failed, complete the following steps.

Note: Removing more than one power supply could result in insufficient system power which could cause some blades to power down. Ensure that there is an

adequate number of active power supply assemblies when removing a single power unit during hot-swap. Refer to "Power supply specifications" and "Power supply requirements" in "Product specifications," on page 195 for minimum power supplies required for low and high voltage line operation.

1. Unplug power cable from failed power supply assembly.
2. Remove power supply assembly.
3. Insert new power supply assembly.
4. Plug power cord into new power supply assembly from power source.
5. Verify power supply assembly status LED.

Replace or install power supply assembly (cold-install or cold-swap)

If your device is up and running, but you want to power down the device to install additional power supply assemblies or replace failed power supply assemblies, complete the following steps.

1. Shut down the system using the **sysShutdown** command.
2. Unplug power cords from all power supply assemblies.
3. If adding a power supply assembly, remove filler panel from empty power supply assembly slot.
4. Install or replace power supply assemblies.
5. Plug power cords into all power supply assemblies from power sources.
6. Verify the power supply assembly status LEDs.

Time and items required

The procedure to remove or install a each power supply takes less than five minutes. A power supply unit or filler panel is required for the power supply replacement.

Removing a power supply

About this task

To remove a power supply, complete the following steps.

Procedure

1. Before removing a power supply assembly, Verify if you can remove a power supply and the leave device operating (hot swap replacement) or must power down the device (cold-swap replacement).

Note: Depending on the blade configuration of the device and the number of power supplies installed, the device may be able to continue operating while replacing a power supply. Refer to "Power supply specifications" and "Power supply requirements" in "Product specifications," on page 195 for minimum power supplies required for low and high voltage line operation, redundancy in case of power supply failure, and other specifications. If there is insufficient power, the device will power down blades until the power demand can be met.

2. Perform one of the following steps:

- If you need to power down the device to remove a power supply, enter the **sysShutdown** command. When command output indicates that the device has completed shut-down, remove power cords from all power supply assemblies.
- If you can leave the device in operation and replace a power supply, unplug the power cord from the power supply assembly that you are replacing.

Note: Be sure to replace the power supply as soon as possible.

3. Loosen the captive screw on the right side of the power supply assembly until the screw releases from the chassis. The captive screw is located just below the airflow label on the right side of the power supply assembly. If necessary use a Phillips screwdriver.
4. Grasp the handle and pull, sliding the power supply from the chassis and supporting the power supply from beneath as you remove it.

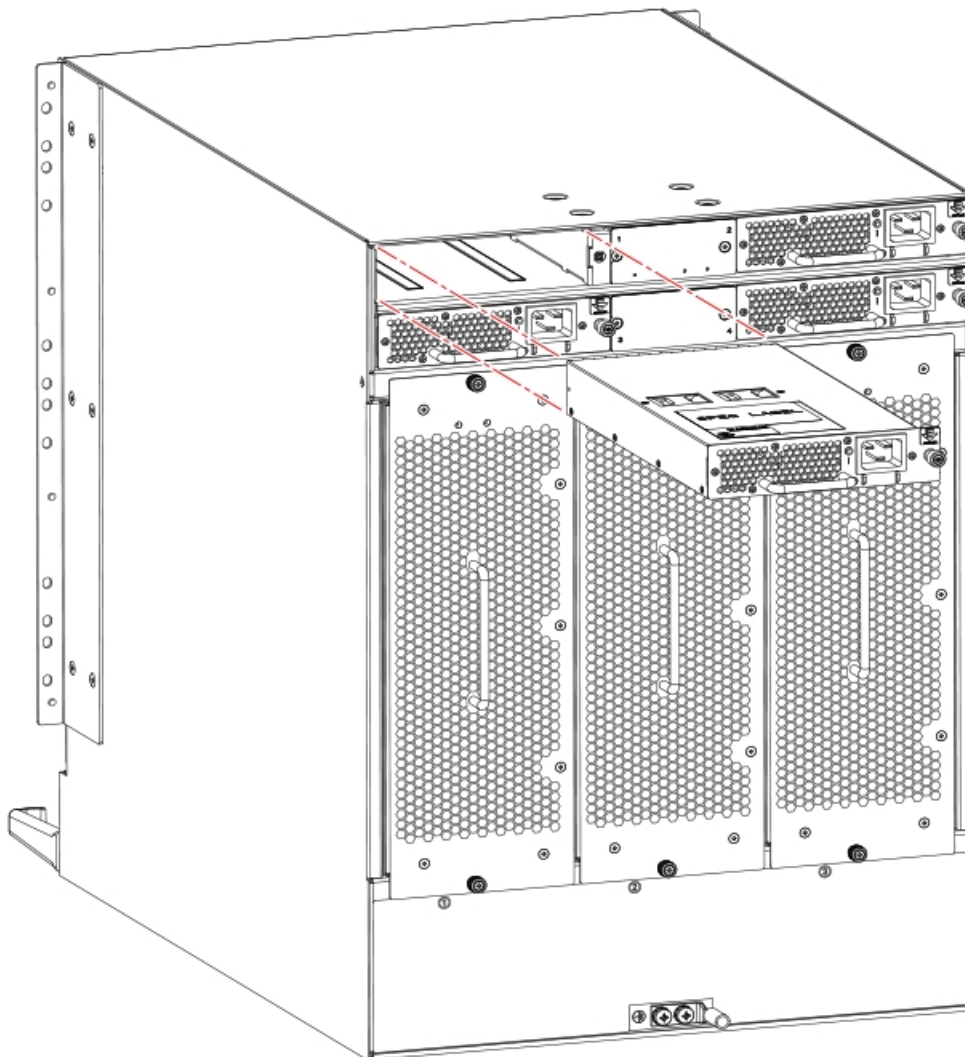

Figure 47. Removing and installing power supply assembly

5. If you are not replacing the power supply and can leave the device operating, insert a filler panel into the slot and tighten captive screw to secure to chassis.

Installing a power supply

About this task

To install a power supply, complete the following steps.

Procedure

1. If a filler panel is installed over the slot where you are installing the power supply, remove the panel by loosening the captive screw located on the right side of the panel. When the screw releases from chassis, pull on the screw to lift the panel from the chassis slot.
2. Grasp the handle and slide the new power supply into the chassis while supporting the power supply from beneath. Push the power supply into slot until the connectors seat in the chassis backplane.
3. Verify that the power supply assembly is seated by gently pushing on the handle.
4. Push in captive screw, and then tighten with fingers to secure power supply assembly to chassis.

Note: Make sure that captive screws securing power supply assembly to chassis are tightened. If not, high pressure from fan operation may unseat power supply assembly from chassis connectors.

5. Plug in the power cord connected to power source.
6. Verify that the power LED on the power supply displays steady green when power is fully applied.
7. If you are installing additional power supplies to bring the total power supplies up to four, perform one or both of the following tasks to enable sending notifications when one power supply fails.

Note: A maximum of four power supplies can be installed in the device.

- For Fabric Watch monitoring, change the switchStatus policy settings to the following:

```
switch.status.policy.PowerSupplies.down = 1
switch.status.policy.PowerSupplies.marginal = 0
```

For more details on executing the **switchStatusPolicyShow** and **switchStatusPolicySet** commands, refer to the *Fabric OS Command Reference*.

- For Monitoring and Alerting Policy Suite (MAPS) monitoring, follow procedures to update the active MAPS power supply switchstatus policy settings for four PSU devices in the "Additional MAPS features" section of the *Monitoring and Alerting Policy Suite Administrator's Guide*.

Verifying power supply operation

About this task

Perform the following tasks to verify operation of the power supply:

Procedure

1. Check the LED indicator on the power supply. The LED patterns may temporarily change during POST and other diagnostic tests. For information on interpreting LED patterns, refer to "Interpreting power supply LEDs" on page 71. Be sure to check all the power supply modules.
2. Check the power supply status by entering the following commands:

The power supply status displays OK, Absent, or Faulty. If a power supply displays absent or faulty, contact the device supplier to order replacement parts. Both physically absent or faulty could also be the result of the power supply not being properly seated or being turned off.

- **psShow** - Displays the status of each power supply as OK, Absent, or Faulty. If a power supply displays absent or faulty, contact the device supplier to order replacement parts. Both physically absent or faulty could also be the result of the power supply not being properly seated or being turned off.
- **sensorShow** - Displays current temperature and status of fan and power supply sensors located on the chassis.
- **errDump** - Displays all system error log messages.
- **errShow** - Displays error log messages one at a time.

Example

Refer to “Using monitoring commands” on page 77 and the *Fabric OS Command Reference* for output examples and additional information on Fabric OS commands.

For more information about error messages, refer to the *Fabric OS Message Reference*.

Chapter 12. Fan Assemblies

This chapter provides the following information:

- “Fan assembly overview”
- “Precautions specific to fan assemblies” on page 164
- “Fan assembly fault indicators” on page 165
- “Fan assembly task guide” on page 165
- “Time and items required” on page 166
- “Removing a fan assembly” on page 166
- “Installing a fan assembly” on page 167
- “Verifying fan operation” on page 168

Fan assembly overview

Following are important details that you should note about fan assemblies:

- Three fan assemblies are installed in the device, containing two fans each, for a total of six fans.
- The device requires 5 fans out of 6 functioning fans for operation.
- Fan assemblies with the following airflow directions can be installed. All fan assemblies must have the same airflow direction and match airflow direction of installed power supplies.
 - Fan assembly with nonport-side air intake. Fans move air from the nonport side to the port side of the device.
 - Fan assembly with nonport-side air exhaust. Fans move air from the port side to the nonport side of the device.
- Fan assemblies can be removed and replaced without special tools.
- The device can continue operation while one fan assembly is replaced if the fan assembly is replaced immediately.

The following figure illustrates fan assembly components.

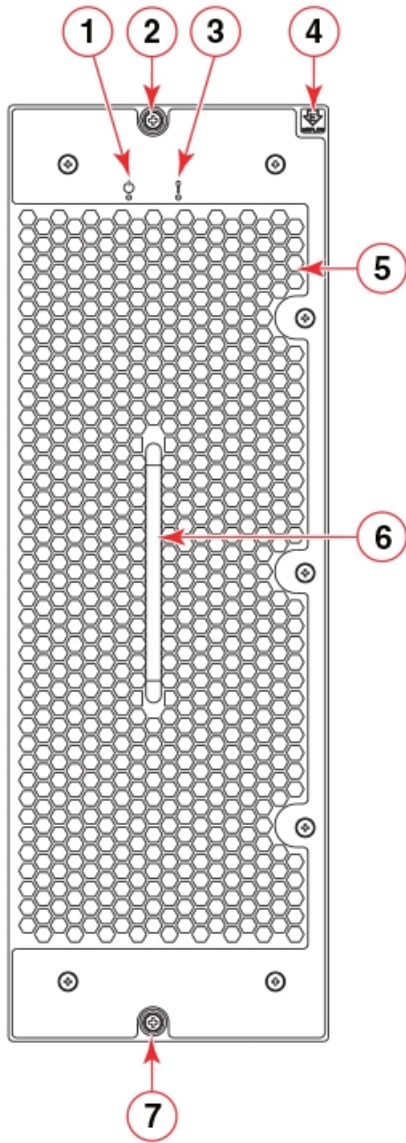

Figure 48. Fan assembly

- 1 - Power LED
- 2 - Captive screw
- 3 - Status LED
- 4 - Airflow label
- 5 - Air vent
- 6 - Handle
- 7- Captive screw

Fan and power supply airflow

All fans and power supply FRUs installed in this device must have either NPI (nonport-side intake) or NPE (nonport-side exhaust) airflow. You must order a replacement FRU with the same part number (P/N) as the FRU being replaced to provide the same airflow. The manufacturing P/N, located on the top of the FRU, contains either NPI or NPE. If a mismatched power source or fan assembly is installed by mistake, a RASlog message occurs indicating that a mismatch in fan or power supply airflow has occurred and the FRU is faulted.

Note: If airflow direction for a power supply assembly does not match the chassis airflow direction as stored on WWN cards, the power supply will have a "fault" status. However, LED operation for the power supply will not indicate a fault. If airflow direction for a fan assembly does not match the chassis airflow direction, the fan LED will indicate a fault condition.

You can use external labels as a guide. The power supply and fan assemblies are labeled with a green "E" or orange "I" airflow symbol on the faceplate. The symbol also appears on the top of the FRU. All fans and power supplies in a chassis must have the same label affixed to guarantee airflow direction is consistent.



Figure 49. Airflow labels

The orange I symbol indicates an intake FRU. This unit pulls air in from the nonport side of the device and exhausts it out the port side. This is called back-to-front airflow or intake airflow. This symbol should appear on FRUs with part numbers that contain an **NPI**.

The green E symbol indicates an exhaust FRU. This unit pulls air in from the port side of the device and exhausts it out the nonport side. This is called front-to-back airflow or exhaust airflow. This symbol should appear on FRUs with part numbers that contain an **NPE**.

Ensure airflow direction of power supply and fan assemblies match airflow direction of the chassis configured on installed WWN cards. If power supply or fan air flow direction does not match, the FRU will fault. Faulty fans can cause increase in temperature.

Airflow direction can be verified by entering the **chassisShow** command. Following is an example from command output indicating mis-matching airflow. WWN units should indicate "Non-portside Intake".

```
POWER SUPPLY Unit: 1
Power Source:          AC
Fan Direction:         Non-portside Intake
...
FAN Unit: 2
Fan Direction:         Non-portside Intake
...
WWN Unit: 1
System AirFlow:        Non-portside Exhaust
...
WWN Unit: 2
System AirFlow:        Non-portside Exhaust
```

Note: Ensure that captive screws securing the fan and power supply assemblies are tightened. If they are not, air pressure inside chassis may unseat these FRUs from chassis connectors.

Fan assembly numbering

The following figure illustrates the location and number identification of fan assemblies in the chassis.

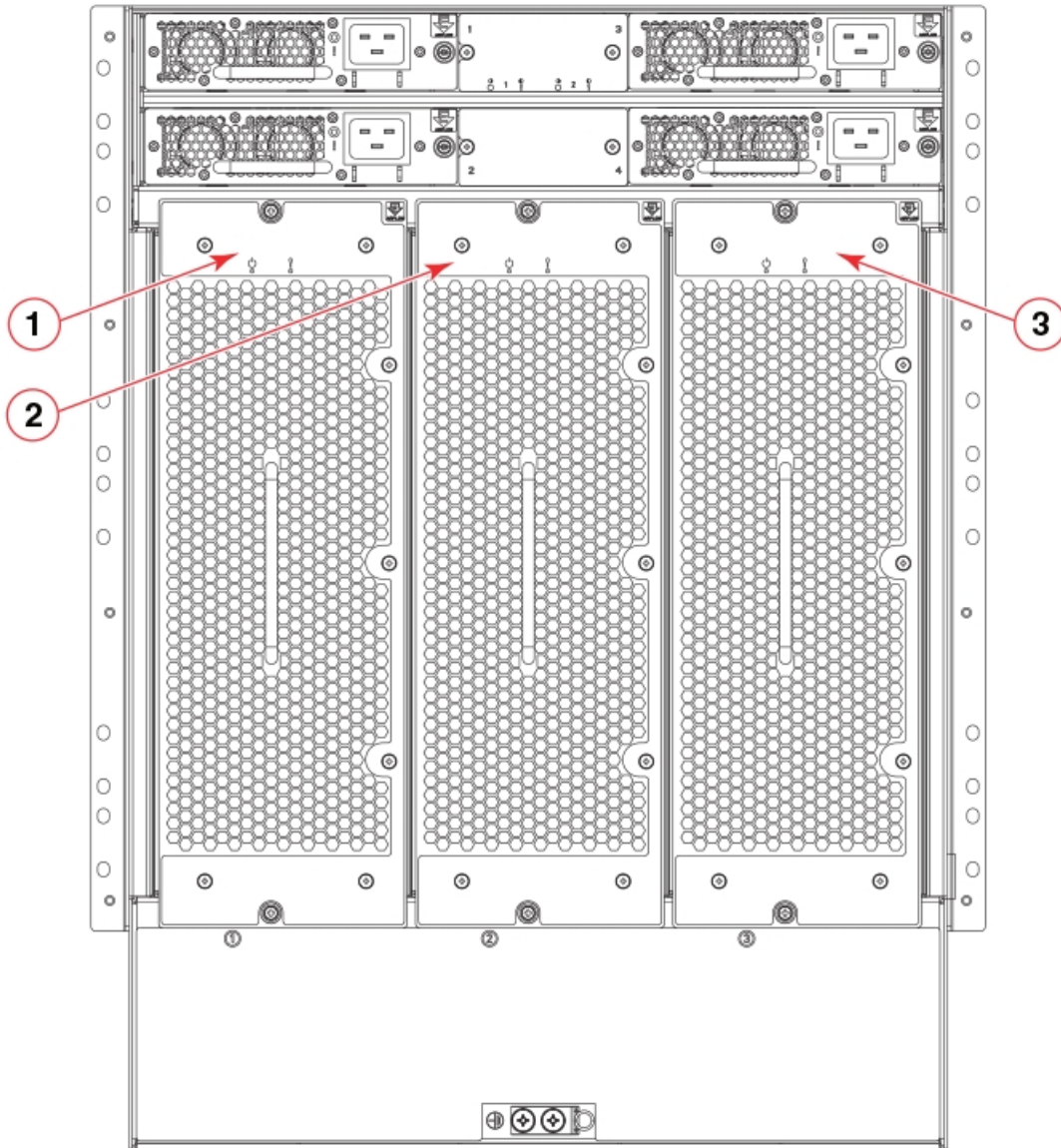

Figure 50. Fan assembly numbering

- 1 - Fan assembly 1
- 2 - Fan assembly 2
- 3 - Fan assembly 3

Precautions specific to fan assemblies

Observe the following precautions when replacing fan assemblies.

Note: Each fan assembly contains two fans for a total of six fans for three installed fan assemblies. The device requires 5 fans out of 6 functioning fans for operation. If hot-swapping a fan assembly, be sure to have the replacement fan assembly ready to install before removing a faulty fan assembly and replace as soon as possible.

Note: If a fan assembly has failed, do not remove it from chassis unless a FRU is available for replacement. If the slot is left empty for an extended time period, this could cause chassis air-leakage and overheating.

Note: Make sure that captive screws securing fan assemblies to chassis are tightened. If not, high pressure from fan operation may unseat fan from chassis connectors.

Fan assembly fault indicators

Use one of the following methods to determine if a fan assembly is faulty:

- Check the fan status LED.
 - Steady amber - fan assembly has a failure (full or partial).
 - Slow-flashing amber (on 2 seconds, then off 2 seconds) - fan assembly is not seated correctly or is faulty.
 - Fast-flashing amber (on ½ second, then off ½ second) - environmental range exceeded.
- Enter **fanShow**. If status of fan assembly displays absent or faulty, check if assembly is seated in chassis. If it is, power supply could be faulty or is not receiving power for some reason.
- Enter **sensorShow** to determine if a fan is running above average temperatures of other installed fan(s).
- Enter **errDump** to display the system error log.

For more information on LED operation, refer to “Interpreting fan assembly LEDs” on page 74.

For output examples and additional information on Fabric OS commands, refer to “Using monitoring commands” on page 77 and the *Fabric OS Command Reference*.

For more information about error messages, refer to the *Fabric OS Message Reference*.

Fan assembly task guide

This section contains a guide to more complete, detailed steps in this section for installing or replacing fan assemblies when the device is running (hot swap) or must be powered off (cold swap). References are provided to the more detailed removal and installation steps for further information.

Note: Each fan assembly contains 3 fans for a total of 6 fans for three installed fan assemblies. The device requires 5 fans out of 6 functioning fans for operation. If hot-swapping a fan assembly, be sure to have the replacement fan assembly ready to install before removing a faulty fan assembly and replace as soon as possible.

Note: If a fan assembly has failed, do not remove it from chassis unless a FRU is available for replacement. If the slot is left empty for an extended time period, this could cause chassis air-leakage and overheating.

Note: Make sure that captive screws securing fan assemblies to chassis are tightened. If not, high pressure from fan operation may unseat fan from chassis connectors.

Replacing fan assembly (hot-swap)

If your device is up and running, but a fan assembly has failed, complete the following steps.

1. Remove fan assembly.
2. Insert new fan assembly into empty slot as soon as possible.
3. Verify that the fan assembly status LED is green.

Replacing fan assembly (cold-swap)

If your device is up and running, but you want to power down the device to replace a failed fan assembly, complete the following steps.

1. Shut down the system using the **sysShutdown** command.
2. Unplug power cords from receptacles on all power supply assemblies.
3. Remove faulty fan assembly.
4. Insert new fan assembly.
5. Plug power cords into all power supply assemblies from power sources to power device on.
6. Verify that fan assembly status LEDs are green.

Time and items required

The replacement procedure for each fan assembly takes less than 5 minutes. The following items are required for the blower assembly replacement:

- Replacement fan assembly
- #1 Phillips screwdriver

Removing a fan assembly

About this task

Complete the following steps to remove a fan assembly from the device.

Procedure

1. Before removing a fan assembly, Verify if you can remove a power supply and leave device operating (hot swap replacement), by referring to “Precautions specific to fan assemblies” on page 164.
2. Perform one of the following steps:
 - If you need to power down the device to remove a fan assembly, enter the **sysShutdown** command. When command output indicates the device has completed shut-down, remove power cords from all power supply assemblies.
 - If you can hot-swap the fan assembly, go on to the next step.

Note: Replace fan as soon as possible to avoid overheating and eventual system shutdown.

3. Loosen the captive screw at each end of the fan assembly until the screw releases from the chassis. Use a #1 Phillips screwdriver if tightened.

4. Grasp the handle and pull, sliding the fan assembly from the chassis while supporting the fan assembly from beneath as you remove it.

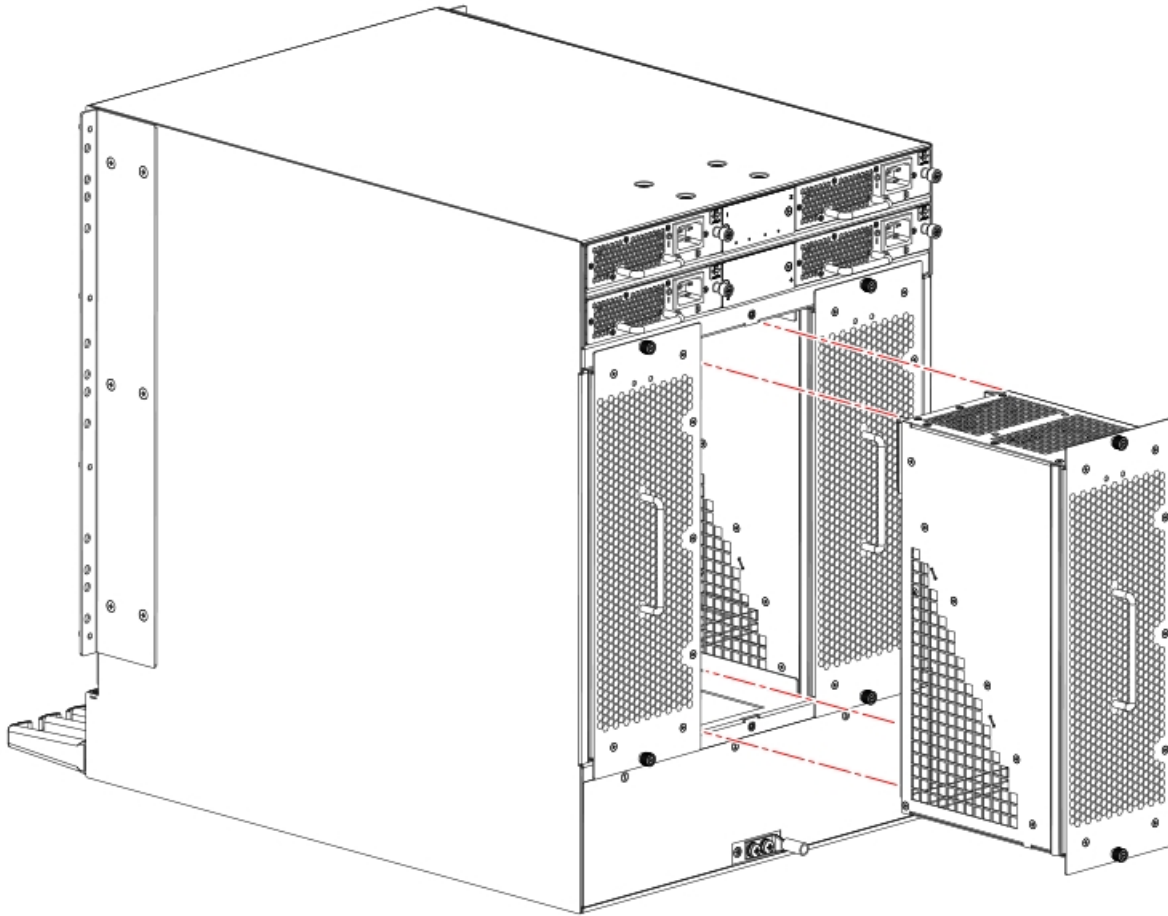

Figure 51. Removing and installing a fan assembly

5. If leaving power on for replacement (hot swap), be sure to replace the fan assembly as soon as possible.

Installing a fan assembly

About this task

Complete the following steps to replace the fan assembly in a device.

Procedure

1. Grasp the handle and carefully slide the fan assembly into the device while supporting the fan assembly from beneath.
2. Push the fan assembly fully into the slot with your fingers until it seats in the backplane connectors.
3. Verify that the power LED displays a green light.
4. Push in on each captive screw and tighten with #1 Phillips screwdriver to secure the fan assembly to the chassis.

Note: Be sure that captive screws are tightened. If not, high pressure from fan operation may unseat fan from chassis connectors.

Verifying fan operation

About this task

Perform the following tasks to verify operation of a fan assembly:

Procedure

1. Check the LED indicators on the fan assemblies. The fan assemblies are located on the nonport side of the device. The LED patterns may temporarily change during POST and other diagnostic tests. For information on interpreting LED patterns, refer to “Interpreting fan assembly LEDs” on page 74.
2. Check the fan assembly status using the following commands:
 - **fanShow** - Displays the status for each fan assembly as OK, Absent, or Faulty. The RPM of each fan in the assembly is also provided. If a fan assembly displays absent or faulty, contact the device supplier to order replacement parts. Both physically absent or faulty could also be the result of the fan not being properly seated in the chassis slot.
 - **sensorShow** - Displays current temperature and status of fan and power supply sensors located in the device.
 - **errShow** - Displays error log messages one at a time.
 - **errDump** - Displays the entire system error log.

Example

Refer to “Using monitoring commands” on page 77 and the *Fabric OS Command Reference* for output examples and additional information on Fabric OS commands.

For more information about error messages, refer to the *Fabric OS Message Reference*.

Chapter 13. Blade Filler Panels

This chapter provides the following information:

- “Blade filler panel removal and replacement”
- “Removing a filler panel”
- “Installing a filler panel” on page 170

Blade filler panel removal and replacement

When installing a blade into the device, you may need to first remove a blade filler panel. Be sure to keep all filler panels in a safe place in case you need to remove a blade for an indefinite period of time. Cover all empty slots with blade filler panels. Failure to do so will adversely affect device cooling.



CAUTION:

If you do not install a module or a power supply in a slot, you must keep the slot filler panel in place. If you run the chassis with an uncovered slot, the system will overheat.

Blade filler panels have a latch mechanism at each end of the panel. Both latches must be opened to remove and install the panel.

Note: Filler panels for SAN768B, SAN384B-2, and SAN768B-2 switches are not interchangeable with filler panels for SAN512B-6 switches.

Removing a filler panel

About this task

Complete the following steps to remove a filler panel from a blade slot.

Procedure

1. Remove the chassis door.
2. Pull out the spring-loaded latch release on the latch at each end of the cover using your thumb and forefinger and slide the latches toward the center of the cover. This moves the latches away from the ends of the slot to unlatch the cover from chassis.
3. Using the latch pull tabs as handles, pull the filler panel out of the chassis.

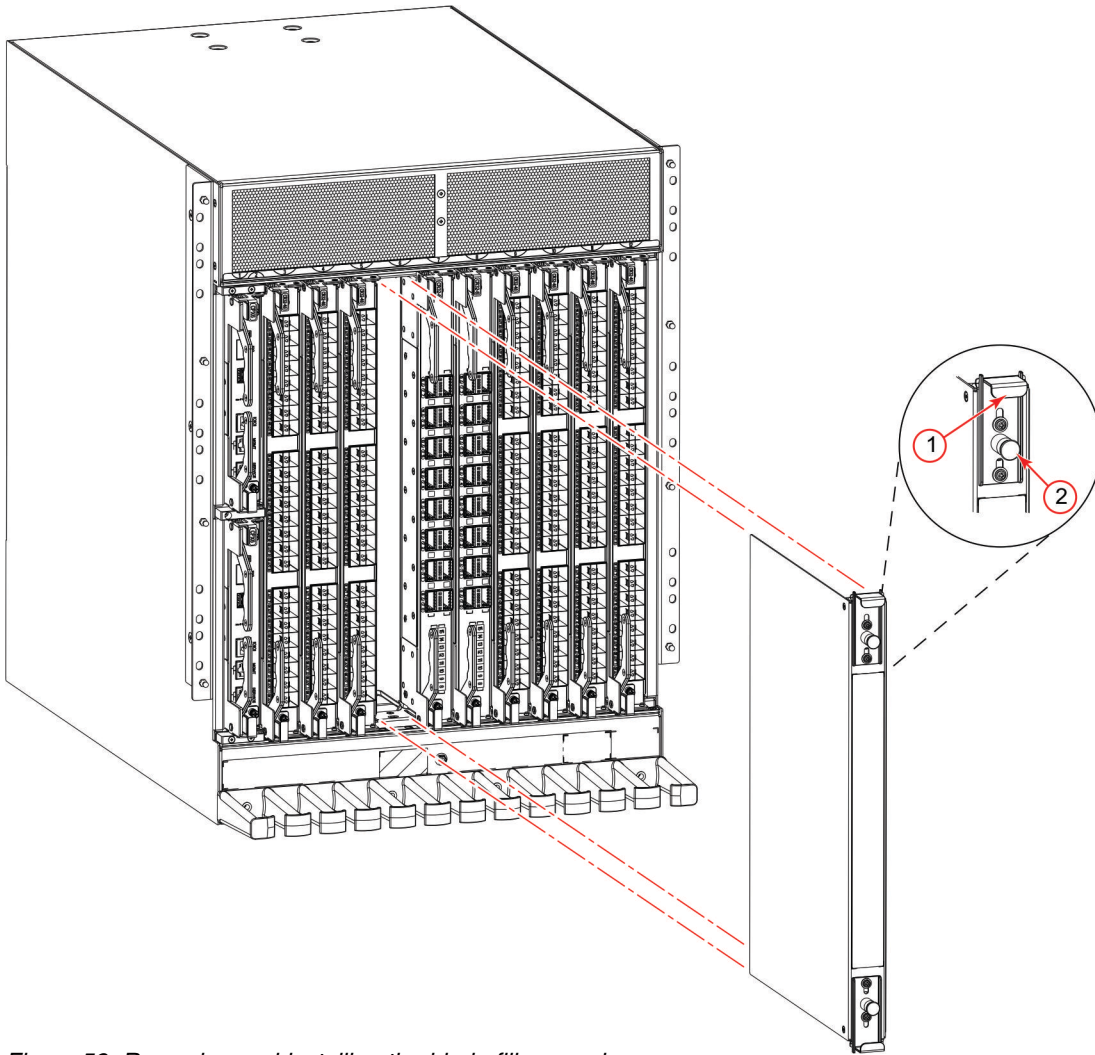

Figure 52. Removing and installing the blade filler panel

- 1 - Latch pull tab
- 2 - Latch release

Installing a filler panel

About this task

Complete the following steps to install a filler panel into a blade slot.

Procedure

1. Pull out the spring-loaded latch release on the latch at each end of the cover using your thumb and forefinger and slide the latches toward the center of the cover.
2. Orient the filler panel over the empty slot and slide into the slot.
3. Pull out the spring-loaded latch release at each end of the cover and slide each latch towards the end of the cover. This should slide the latches into the chassis and lock the panel in place. If not, the cover may not be seated fully into the slot. Try unlatching both ends, pushing the cover firmly into the slot, then latching both ends again.

Note: Be sure filler panels are securely latched. If not, high pressure from fan operation may unseat blade from chassis connectors.

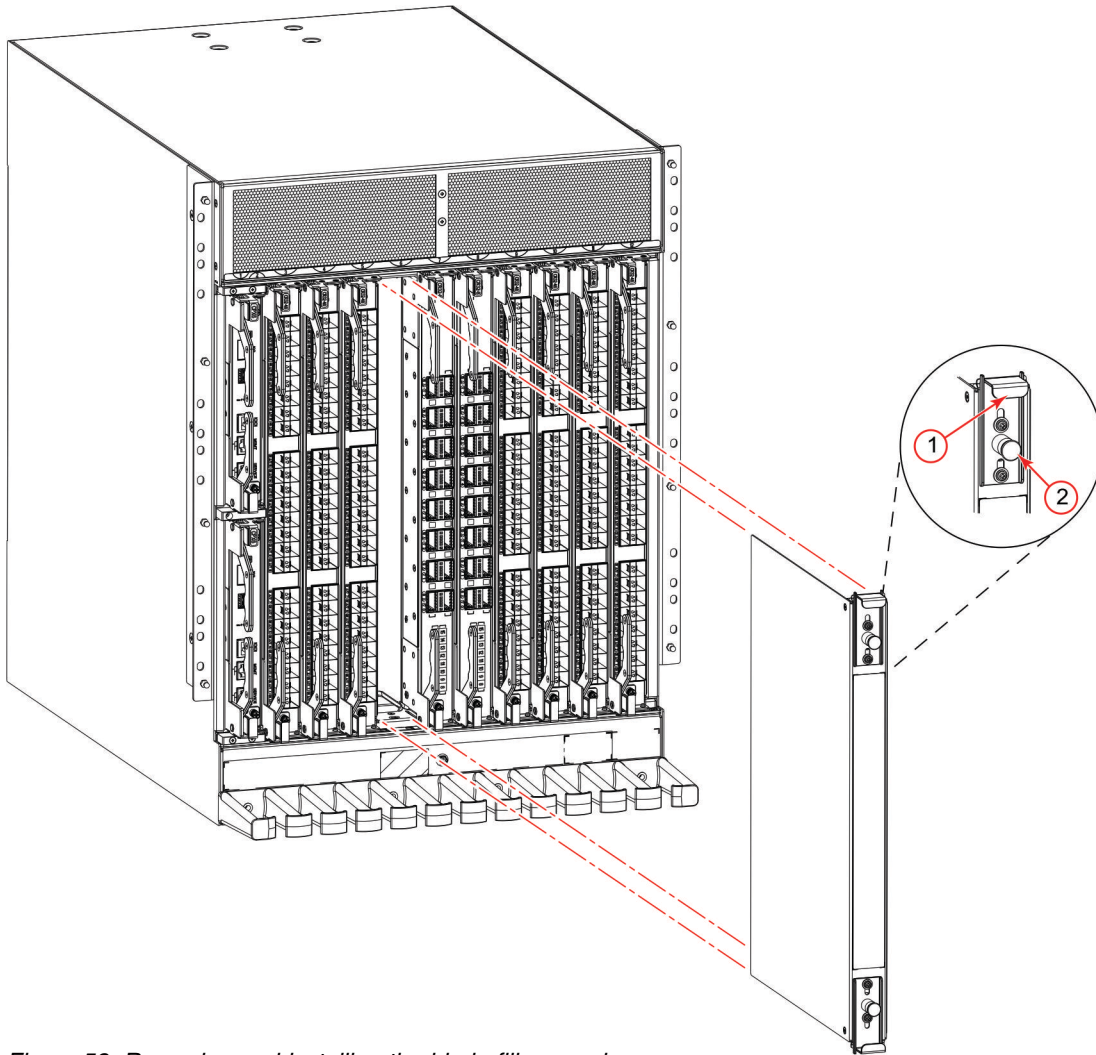

Figure 53. Removing and installing the blade filler panel

4. Reinstall the chassis door. The door must be installed to meet EMI compliance.

Chapter 14. Cable management comb

This chapter provides the following information:

- “Cable management comb overview”
- “Time and items required for removal and installation”
- “Removing cable management comb”
- “Installing cable management comb” on page 174

Cable management comb overview

Use the cable management comb to organize and route cables attached to blade ports. The SAN512B-6 can continue to operate while removing or installing the cable management comb.

Time and items required for removal and installation

The replacement procedure for the cable management comb takes less than five minutes. A #1 Phillips screwdriver is required.

Removing cable management comb

About this task

Complete the following steps to remove the cable management comb.

Procedure

1. Remove the cables from the cable management comb and rearrange the cables around the comb.
2. Unscrew and save the four (4) screws holding the comb to the device. Support the comb to prevent it from falling.
3. Remove the cable management comb.

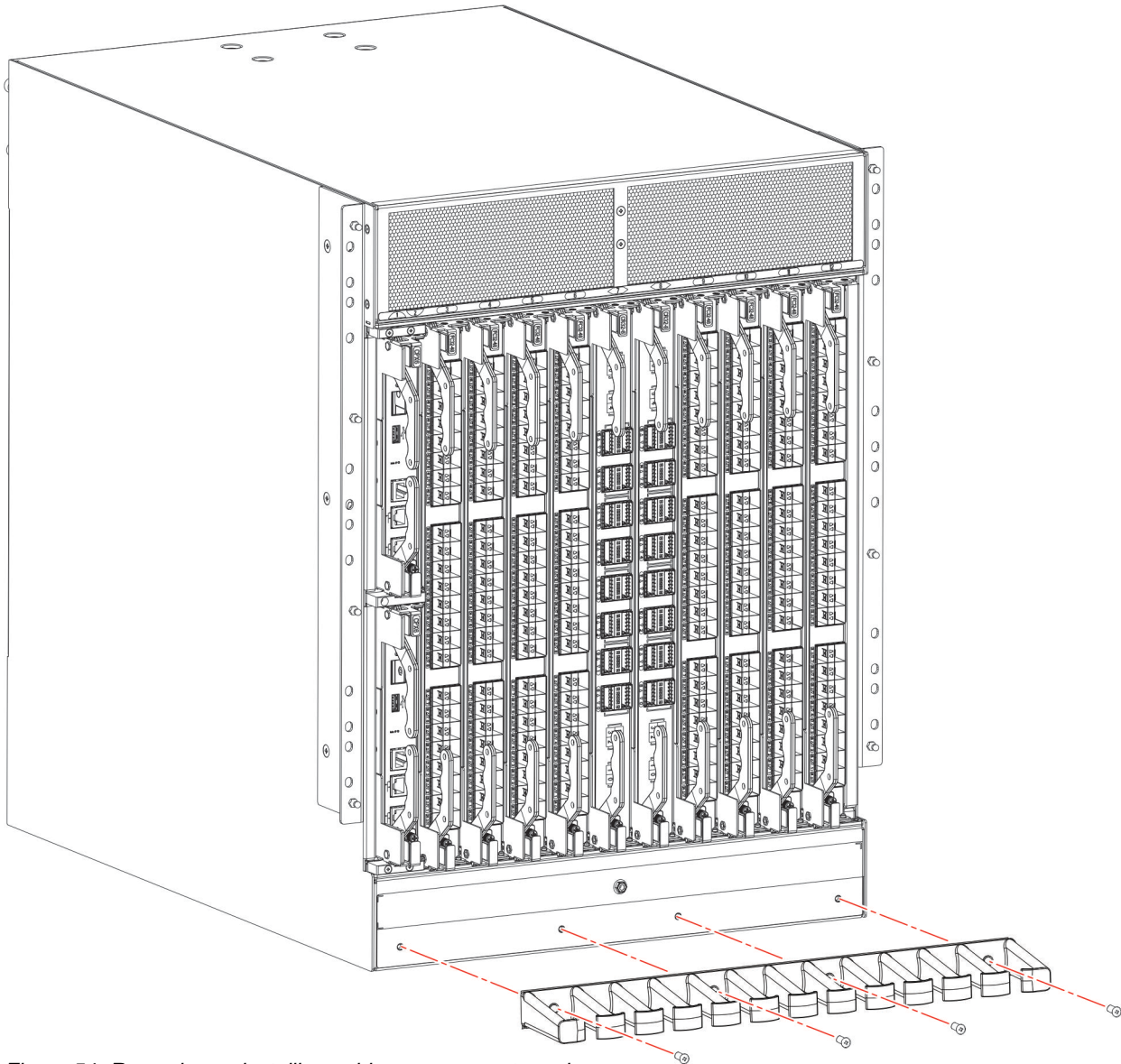

Figure 54. Removing or installing cable management comb

Installing cable management comb

About this task

Complete the following steps to replace the cable management comb.

Procedure

1. Position and tighten the four (4) screws to secure the cable management comb to the chassis.
2. Arrange the cables along the cable management comb.

Chapter 15. Chassis door

This chapter provides the following information:

- “Chassis door overview”
- “Time and items required”
- “Removing a chassis door”
- “Installing a chassis door” on page 176

Chassis door overview

The chassis door must be installed to ensure that the device meets EMI and other regulatory certifications. A receiving hole is located on each corner on the back side of the door. Each hole snaps into a ball stud located on a matching corner of the chassis.

Time and items required

The first-time installation procedure for the chassis door takes 15 minutes due to installation of ball studs. Thereafter, removal and reinstallation should take less than 5 minutes.

Required for installation are the door assembly, packaged separately from the chassis, and ball studs for the door. Ball studs are packaged with the door assembly.

Removing a chassis door

Support the door to prevent it from falling. Pull and remove the door. It will pop off the ball studs.

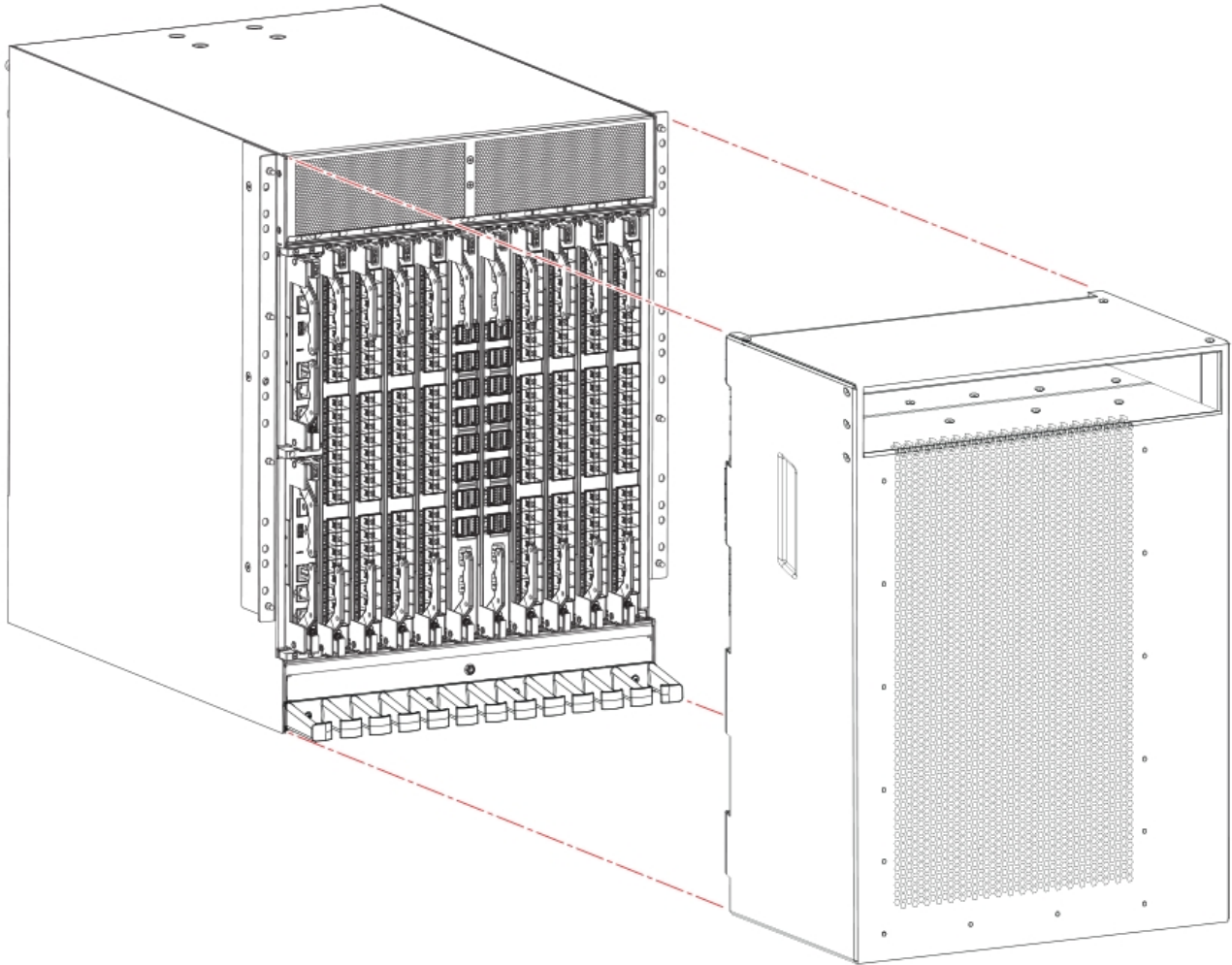

Figure 55. Removal and replacement of the chassis door

Installing a chassis door

About this task

Complete the following steps to install the door on the port side of the chassis.

Before installing the door, use step 1 to remove the protective cover if it is attached over the air vents at the top of the chassis. If the protective cover has been removed, skip to step 2 to install the door.

Procedure

1. Unfasten the protective cover from the chassis mounting bracket by removing the two 6-32 X 3/8 in. panhead Phillips screws securing the cover to the bracket using a Phillips screwdriver. One screw is located above the bracket and one beneath the bracket. You do not need to remove the mounting bracket (1 in following illustration) from the chassis. Save the cover and other parts for future installation.

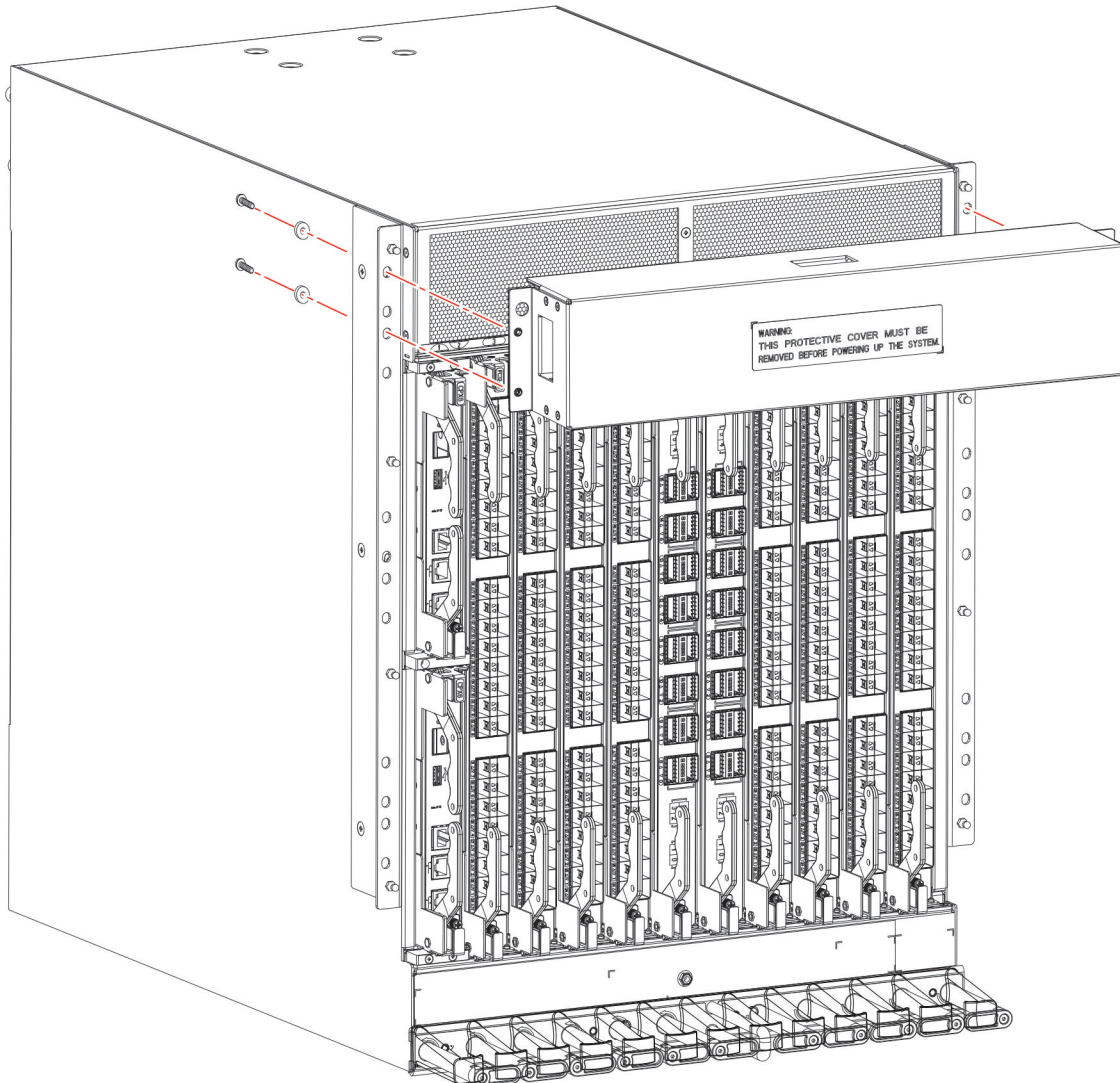

Figure 56. Removing protective cover from SAN512B-6 chassis

2. Align the ball stud attachment holes located vertically on each side of the rear of door with the ball studs on each chassis mounting ear. Push door onto chassis to snap onto the studs.

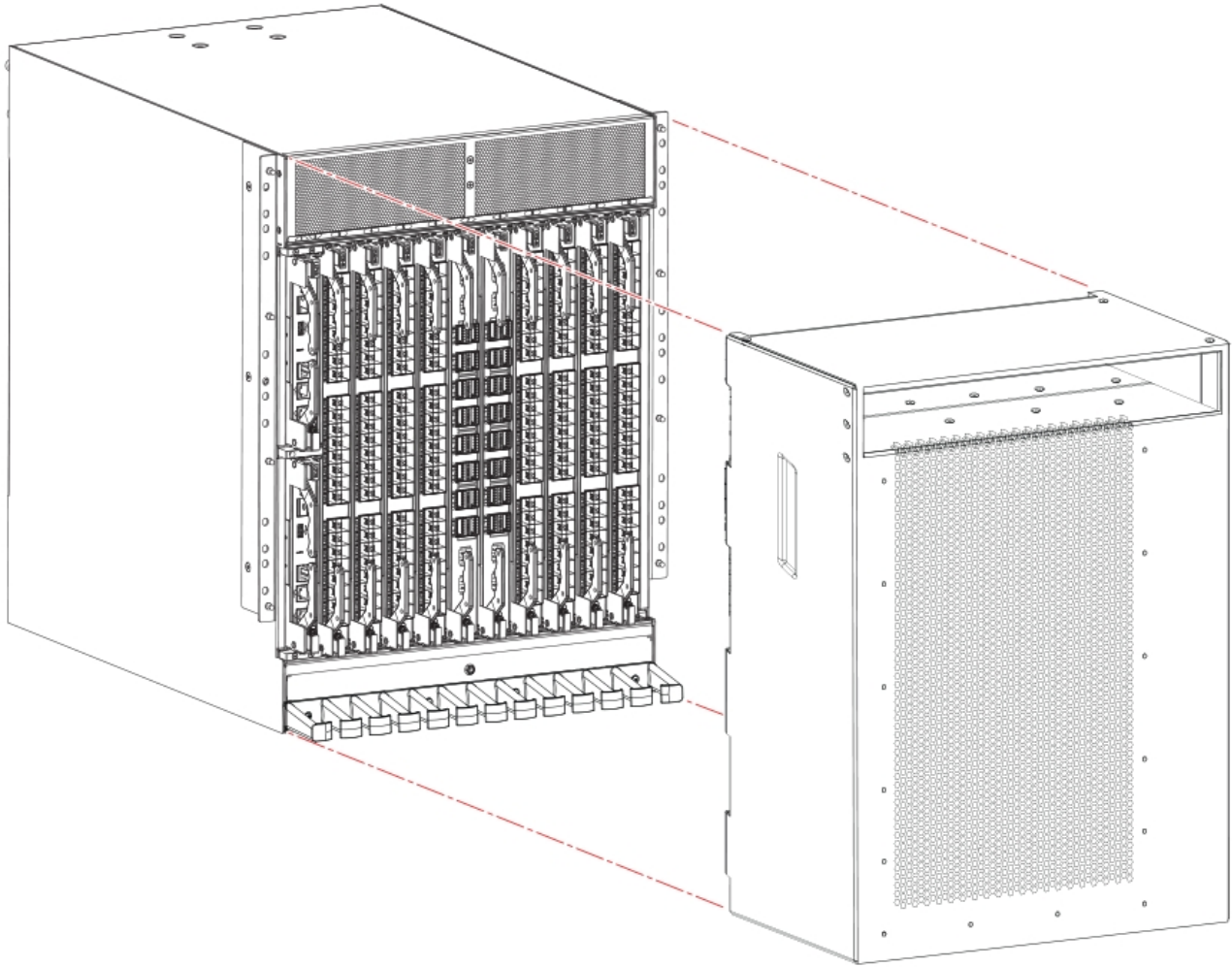

Figure 57. Removal and replacement of the chassis door

Chapter 16. Replacing the Chassis

This chapter provides the following information:

- “Chassis replacement overview”
- “Precautions specific to chassis replacement”
- “Chassis replacement task guide” on page 180
- “Chassis fault indicators” on page 181
- “Time and items required” on page 181
- “Preparing for replacement” on page 182
- “Removing components from the chassis” on page 186
- “Installing components into the chassis” on page 188
- “Synchronizing airflow direction on WWN cards” on page 189
- “Downloading the configuration” on page 189
- “Verifying correct operation of system” on page 190
- “Reconnecting system to the network and fabric” on page 191
- “Verifying correct configuration of the fabric” on page 192

Chassis replacement overview

Before replacing the chassis, you will need to remove all blades and FRUs, except the WWN cards, from the existing chassis. You will reinstall these in the replacement chassis. Do not remove components without following procedures in this section exactly as you will need to save critical device and SAN information for these components before disconnecting the chassis from the network, fabric, and power to begin removal procedures. After you reinstall components in the new chassis, follow exact procedures to reconnect to the network, fabric and power, and then download firmware if necessary and verify system operation and configuration.

Note: You will not remove WWN cards from the old chassis as new cards are shipped in the replacement chassis.

Before beginning these procedures, perform the following tasks:

- Place the replacement chassis in close proximity to the old chassis.
- Provide a surface on which to place the old chassis, such as a second lift or the pallet originally provided with the chassis.
- Obtain all tools and other materials listed under “Time and items required” on page 181.

To unpack and transport the new chassis, follow procedures under “Unpacking and transporting the device” on page 19.

Precautions specific to chassis replacement

Observe the following precautions when replacing the chassis.

When removing components, Wear a wrist grounding strap connected to bench ground.



DANGER

For safety reasons, the ESD wrist strap should contain a series 1 megaohm resistor.



DANGER

Disconnect the power cord from all power sources to completely remove power from the device.



DANGER

Use safe lifting practices when moving the product.



DANGER

Make sure the rack housing the device is adequately secured to prevent it from becoming unstable or falling over.



DANGER

A completely empty chassis weighs approximately 24.49 kg (54.0 lb) and requires a hydraulic or assisted lift to install it.

Chassis replacement task guide

About this task

Following are the basic tasks for removing and replacing the chassis with its backplane.

Note: The device must be removed from the fabric and powered off to perform these tasks. Contact your support provider if you have any questions about whether the chassis requires replacement.

Procedure

1. "Recording critical device and SAN information" on page 182
2. "Disconnecting from network and fabric" on page 185
3. "Removing components from the chassis" on page 186
4. "Installing the replacement chassis" on page 187
5. "Installing components into the chassis" on page 188
6. "Downloading the configuration" on page 189

7. "Verifying correct operation of system" on page 190
8. "Reconnecting system to the network and fabric" on page 191
9. "Verifying correct operation of system" on page 190

Chassis fault indicators

Verify that replacement of the chassis is necessary. If error messages and LED operation indicates faulty components, ensure that the components are firmly seated. Contact your support provider with any questions about whether the chassis should be replaced.

Any of the following events might indicate the need to replace the chassis:

- Visible mechanical damage to the chassis, including damage to sheet metal or card guides that prevents correct installation of a blade.
- Bent or damaged connectors on the backplane (the surface inside the chassis to which the blades connect).
- One or more components (such as a power supply, blower assembly, port blade, control processor blade, core switch blade, or WWN card) do not function properly even after the component was replaced.
- Intermittent **FAULTY** codes for blades. Reseat the blade and visually inspect the ejector stiffening rails for possible wear or damage. It is important that the blade ejector handles not slip out during blade installation. If this happens, it is usually due to excessive wear or damage to the ejector stiffening rails.
- The **psShow** or **fanShow** commands continue to show a faulty component even though the component was replaced.
- The **sIotShow** command continues to show a faulty control processor, core switch, or port blade even though the blade was replaced.

Time and items required

The chassis replacement takes approximately 3 to 4 hours.

The following items are required for the chassis replacement:

- Electrostatic discharge (ESD) grounding strap
- ESD grounding pads for protecting all blades and WWN cards
- Serial cable and workstation computer with a terminal emulator application (such as HyperTerminal for Windows systems or TIP for Solaris systems), required only if serial console session used.
- Hydraulic or assisted lift with a minimum raise of 140 cm (55 in.) and a minimum capacity of 158.76 kg (350 lbs)

DANGER

If a lift tool with a capacity of at least 350 lbs is not available, the director chassis must be depopulated completely before installing it into the rack. Remove the power supplies, fan modules, all of the blades, the cable management comb, and the chassis door (if equipped). Install the empty chassis into the rack following the chassis installation instructions. The weight of the empty chassis is 78.5 lbs (35.6 kg) and must be lifted by minimum 3 people. After securing the chassis to the rack, reinstall the power supplies, fan modules, and the blades and proceed with the installation.

- A surface on which to place the old chassis, such as a second lift or the pallet originally provided with the old chassis.
- #1 and #2 Phillips screwdriver. Use #1 Phillips screwdriver for removing and installing blades and FRUs in chassis.

Preparing for replacement

Before beginning replacement procedures you must run the a series of Fabric OS commands and record device information for safekeeping that may be required for installing and configuring the new chassis. This includes information on licenses, IP address, WWN, serial numbers, switch ID, location of configuration files, and fabric details. It also includes information that might be required by Technical Support. "Recording critical device and SAN information" instructs you to run the following commands and record specific output:

- supportShow
- configUpload - all
- configupload -vf
- ipAddrShow -sw
- chassisShow
- nsShow
- nsAllShow
- switchShow -qsfp
- fabricShow
- licenseShow
- supportShow

Before beginning replacement, you must also properly shut down the device and disconnect from the fabric and power using procedures under "Disconnecting from network and fabric" on page 185.

Recording critical device and SAN information

About this task

Perform the following steps. All commands must be entered from a CLI session (telnet or serial) to the active CP blade unless otherwise indicated.

Procedure

1. Run **supportShow**, which includes most of the information in the following table and more. Be sure to record the location of the .txt files that you create in this procedure that are not called out in the **supportShow** results. For

detailed information about Fabric OS commands, refer to the *Fabric OS Command Reference*. Use a checklist to ensure that all required information is recorded.

Table 20. Critical information checklist

Checked?	Data	Notes
Configuration information		
	Location of "config-switch.txt" file	
	Location of "config-miscinfo.txt" file	
	IP address, subnet mask	
	WWN for the device	
SAN profile		
	Location of "SANbefor.txt" file	
	Notes regarding nsshow output	
	Notes regarding nsallshow output	
	Notes regarding switchshow output	
	Notes regarding fabricshow output	
Output from licenseshow command		
	License keys and other licensing data for licensed products enabled on device.	
Output from supportshow command		
	Location of "sptshow.txt" file	
	Notes regarding supportshow output	
Information about the new chassis		
	New factory serial number	
	New serial number (if available)	

- Open a telnet session and log into the device as **admin**. The default password is *password*. Enable the logging function on your telnet or serial console connection.
- Back up the current configuration by entering the **configUpload -all**. Enter the requested information at the prompts.

Note: If you are using the Virtual Fabric feature, run **configupload -vf** before running the **configupload** command to save the logical switch configuration.

This **configUpload -all** command uploads the device configuration to the customer-defined FTP server, making it available for downloading.

Alternatively, you can save the configuration file to a USB device. For more information about this command, refer to the *Fabric OS Command Reference*.

```
switch:admin> configupload
Protocol (scp or ftp) [ftp]: ftp
Server Name or IP Address [host]: 123.123.123.123
User Name [user]: Admin24
File Name [config.txt]: config-switch0.txt
Password:
Upload complete
switch:admin>
```

4. Record the WWN value: Enter **wwn**, and then copy the command output into a file named config-miscinfo.txt.

```
switch:admin> wwn
10:00:00:60:69:00:00:0a
```

5. Enter **ipAddrShow -sw**, and then copy the command output into the config-miscinfo.txt file.

```
switch:admin> ipaddrshow -sw
SWITCH
Ethernet IP Address: 14.25.60.14
Ethernet Subnetmask: 255.55.0.0
Fibre Channel IP Address: 1.2.3.4
Fibre Channel Subnetmask: 255.255.255.0
CP0
Ethernet IP Address: 14.25.60.10
Ethernet Subnetmask: 255.55.0.0
HostName : cp0
Gateway Address: 14.25.43.1
CP1
Ethernet IP Address: 14.25.50.13
Ethernet Subnetmask: 255.55.0.0
HostName : cp1
Gateway Address: 14.25.43.1
Backplane IP address of CP0 : 14.11.0.6
Backplane IP address of CP1 : 14.11.0.7
switch:admin>switch:admin>
```

6. Display and record the manufacturer serial numbers.

Enter **chassisShow**, and then copy the command output into the config-miscinfo.txt file.

"Factory Serial Num" and "Serial Num" are listed under "Chassis/WWN Unit 1" and "Chassis/WWN Unit 2". If the current WWN cards are the original cards, the factory serial number listed is the same as the chassis serial number. For example output from the **chassisShow** command, refer to "switchShow" on page 91.

7. Create a SAN "profile" by entering and recording the information provided by the following commands:

- **nsShow**
- **nsAllShow**
- **switchShow -qsfp**
- **fabricShow**

Copy the command output into a text file named "SANbefor.txt." After the device is restored to the fabric, this information can be used to verify that no unintentional changes have occurred to the fabric.

```
switch:admin> nsshow
Enter Pid COS PortName NodeName TTL
<output truncated>
switch:admin> nsallshow
12 Nx_Ports in the Fabric
```

```

<output truncated>
switch:admin> switchshow
switchName: switch
<output truncated>
switch:admin> fabricshow
Switch ID Worldwide Name Enet IP Addr FC IP Addr Name
<output truncated>
switch:admin>

```

8. Enter **licenseShow**, and then copy the command output into a text file named "licenseshow.txt."

```

switch:admin> licenseshow
S9bddb9SQbTAceeC:
Fabric license
eezeRRySff0fSe:
Remote Switch license
bzbzRcbcSc0c0SY:
Remote Fabric license
dSeR9RcSeeTfSAq:
Extended Fabric license
RyeSzRScycTzft09:
Entry Fabric license
RyeSzRScyczft0G:
Trunking license
RyeSzRScycS0ft09:
4 Domain Fabric license

```

9. Enter **supportShow**; then copy the command output into a text file named "spptshow.txt."

Note: The **supportShow** command has a very long output and time for completion. It may last 20 minutes or longer depending on the size of the SAN.

This file provides a backup of all the information that might be required by Technical Support. The information can be used after the device is restored to the fabric to verify that no unintentional changes have occurred to the fabric.

```

switch:admin> supportshow
version: 8.0.1
<output truncated>
switch:admin>

```

10. Record the cable connections between the chassis and the target device and ports.
11. Run **supportSave** on the active CP blade. The information recorded can be very important in case you have difficulties during the replacement process.

Disconnecting from network and fabric

About this task

Complete the following steps to disconnect the chassis from the network.

Procedure

1. Shut down the device using the **sysShutdown** command on the active CP blade.

```

switch:admin> sysshutdown
This command will shutdown the operating systems on your switch.
You are required to power-cycle the switch in order to restore operation.
Are you sure you want to shutdown the switch [y/n]?y
HA is disabled
Stopping blade 1
Shutting down the blade....
Stopping blade 2
Shutting down the blade....

```

Stopping blade 8
Shutting down the blade....
Broadcast message from root (pts/1) Tue April 12 14:23:06 2008...
The system is going down for system halt NOW !!



DANGER

Disconnect the power cord from all power sources to completely remove power from the device.

2. Power off the chassis by removing the power cords from the power supplies and the power outlets.
3. Remove the chassis door.
4. Label the cables connected to all blades and record the connections. Per connection, identify the slot and port, the device connected, and the slot or port on the connected device.
5. Disconnect the cables from the transceivers in extension, port, and core routing blades and set them aside. For transceivers with integrated cables, remove the transceivers and cables together and set them aside. Transceivers without integrated cables can be left in the blades or removed.
6. Disconnect all cables from the CP blades.

Removing components from the chassis

About this task

Follow electrostatic discharge (ESD) precautions when removing components. Wear a wrist grounding strap connected to chassis ground (if the device is plugged in) or a bench ground.

Note: You do not need to remove WWN cards from the chassis as new WWN cards are shipped with the replacement chassis.

When removing components, Wear a wrist grounding strap connected to bench ground.



DANGER

For safety reasons, the ESD wrist strap should contain a series 1 megaohm resistor.

Procedure

1. Remove the chassis door (“Removing a chassis door” on page 175) if not already removed.
2. Remove the cable management comb (“Removing cable management comb” on page 173).
3. Remove the port, extension, blades or filler panels (“Removing a blade” on page 103 and “Removing a filler panel” on page 169).
4. Remove the core routing blades (“Removing a core routing blade” on page 115).
5. Remove the control processor blades (“Removing a blade” on page 127).

6. Remove the power supply assemblies or filler panels (“Removing a power supply” on page 156).
7. Remove the fan assemblies (“Removing a fan assembly” on page 166).

Installing the replacement chassis

About this task

Complete the following steps to install the replacement chassis.



DANGER

Use safe lifting practices when moving the product.

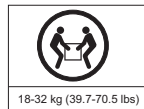

DANGER

A completely empty chassis weighs approximately 24.49 kg (54.0 lb) and requires a hydraulic or assisted lift to install it.

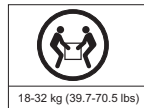

DANGER

Make sure the rack housing the device is adequately secured to prevent it from becoming unstable or falling over.

Procedure

1. If the chassis is in a rack, remove it from the rack.
2. Place the chassis on a lift or on the shipping pallet provided with the original chassis and transport to storage location.
3. Unpack the new chassis.
 - a. Cut the bands that encircle the packaging.
 - b. Open the top of the shipping box and remove accessory kit, rack mount kits, and foam from the top of the chassis.
 - c. Lift the cardboard shipping container and inner cardboard sleeve off the chassis.
 - d. Remove the antistatic plastic off the chassis.
 - e. Save the packing materials for use when returning the old chassis.
 - f. Leave the chassis on top the foam shipping tray and wood pallet if the chassis must be transported to the installation location.
 - g. Verify the contents of the shipping carton by referring to “Items shipped” on page 15.
 - h. Save foam packing material and wooden pallet for reuse.
4. Use a pallet jack or other assisted lift to transport the new chassis to the installation area. Doorways must be wider than 91 cm (36 in.) to accommodate the chassis on the pallet.
5. Use a lift to raise the chassis to the correct level. If installing the chassis in a rack, follow the instructions provided by the rack kit manufacturer.

Installing components into the chassis

About this task

Follow electrostatic discharge (ESD) precautions when installing new components. Wear a wrist grounding strap connected to chassis ground (if the device is plugged in) or a bench ground.



DANGER

For safety reasons, the ESD wrist strap should contain a series 1 megaohm resistor.

Procedure

1. Record the chassis serial number, SKU, and WWN printed on the chassis label. This label is located on the upper portion of the chassis to the left of the fan assemblies on the nonport side. You may need this information to transfer licenses to the new chassis.
2. Replace the fan assemblies (“Installing a fan assembly” on page 167).
3. Replace the power supplies or filler panels (“Installing a power supply” on page 158).
4. Replace the control processor (CP) blades (“Replacing a CP blade” on page 126).
5. Replace the core routing (CR) blades (“Installing a blade” on page 134).
6. Replace the port and extension blades or filler panels (“Installing a blade” on page 105 and “Installing a filler panel” on page 170).
7. Replace the cable management comb (“Installing cable management comb” on page 174).
8. Replace the chassis door. The door is required to meet EMI compliance. Refer to “Installing a chassis door” on page 176.
9. Plug in power cords from power source into all installed power supplies to power on device. Refer to (“Providing power to the device” on page 37).
The device performs a power-on self-test (POST). The POST takes a minimum of three minutes and is complete when LED activity returns to the standard state. The power supply LED will light green when power is applied. Note that after one power supply is plugged into AC power, LEDs on the remaining installed power supplies will flash green until they also have full power.
10. Verify that the device is powered on and POST is complete (all power LED indicators on the blades should be a steady green).
11. Verify that all components are functioning correctly by checking their LEDs. If the LEDs do not indicate correct operation, try reinstalling the corresponding component.
12. Perform the following procedures in order to complete this installation:
 - a. “Downloading the configuration” on page 189
 - b. “Verifying correct operation of system” on page 190
 - c. “Reconnecting system to the network and fabric” on page 191
 - d. “Verifying correct configuration of the fabric” on page 192
 - e. “Synchronizing airflow direction on WWN cards” on page 189

Synchronizing airflow direction on WWN cards

An airflow direction mismatch may occur if the airflow direction, nonport-side intake (NPI) or nonport-side exhaust (NPE), for installed fan and power supply assembly FRUs does not match airflow direction set on new WWN cards shipped with replacement chassis.

You can check airflow direction for fans in fan and power supply assemblies installed in device with airflow direction set on WWN cards by entering the **chassisShow** command. Airflow direction of fans and power supplies displays as "Fan Direction" under each fan or power supply unit. System airflow direction displays as "System Airflow" under the WWN card unit.

If the chassisShow command or RASlog messages indicate a mismatch between system airflow direction and airflow direction of fan in power supply or fan assemblies refer to "Configuring airflow direction on WWN cards" on page 147 for instructions on configuring correct airflow direction on WWN cards.

Note: Changing chassis airflow allows you to synchronize established chassis airflow direction from installed fan and power supply assemblies with airflow direction configured on WWN cards. This procedure may need to be used after replacing WWN cards. This procedure must be performed when replacing the chassis, as replacement chassis are shipped with new WWN cards installed and airflow direction is not configured on these cards. This procedure is not supported for any other purpose.

Downloading the configuration

About this task

Once the chassis and its various components have been reassembled and powered back on, use the **configDownload** command to restore the original configuration. The **configDownload** command can be entered through a Telnet or serial session, but the device must have an Ethernet connection to the server name or IP address of the host for the download process to complete. For more information, refer to the **help configdownload** command or the *Fabric OS Command Reference*.

Complete the following steps to download the configuration.

Procedure

1. Log in to the device as **admin**.

```
switch:admin> login
login: admin
password: xxxxxxxx
switch:admin>
```

Note: If you are using the Virtual Fabric feature, you must run **configdownload -vf** before running the **configdownload** command to restore the logical switch configuration.

2. Enter the **chassisDisable** command.
3. Enter the **configDownload** command.

```
switch:admin> configdownload -all
Server Name or IP Address [host]: 123.123.123.123
User Name [None]: Admin24
```

```
File Name [config.txt]: config-switch.txt
Password: xxxxxxxx
download complete
switch:admin>
```

4. Reboot the device.
5. Enter the **chassisEnable** command to enable all user ports and enable a virtual fabric-aware chassis.

Verifying correct operation of system

About this task

Complete the following steps to verify the correct operation of the device.

Procedure

1. Log in to the device as **admin**.

```
switch:admin> login
login: admin
password: xxxxxxxx
switch:admin>
```

2. Enter the **chassisShow** command to verify that airflow direction set on WWN cards matches airflow direction for fans in fan and power supply assemblies installed in device. Airflow direction of fans and power supplies displays as "Fan Direction" under each fan or power supply unit. System airflow direction displays as "System AirFlow" under the WWN card unit. The following example shows mismatch of system airflow and airflow direction in installed fan and power supply.

```
POWER SUPPLY Unit: 1
Power Source:          AC
Fan Direction:         Non-portside Intake
...
FAN Unit: 2
Fan Direction:         Non-portside Intake
...
WWN Unit: 1
System AirFlow:       Non-portside Exhaust
...
WWN Unit: 2
System AirFlow:       Non-portside Exhaust
```

The WWN units should indicate "Non-portside Intake." If there is a mismatch of airflow direction, RASlog messages will indicate a mismatch between system airflow direction and airflow direction of fan in power supply or fan assembly refer to "Configuring airflow direction on WWN cards" on page 147 for instructions on configuring correct airflow direction on WWN cards.

3. Enter the **slotShow -m** command and verify that all the installed cards are detected and that their status is operational (enabled).

```
switch:admin> slotShow -m
```

Slot	Blade Type	ID	Model Name	Status
1	CP BLADE	175	CPX6	ENABLED
2	CP BLADE	175	CPX6	ENABLED
3	SW BLADE	178	FC32-48	ENABLED
4	SW BLADE	178	FC32-48	ENABLED
5	AP BLADE	186	SX6	ENABLED
6	SW BLADE	178	FC32-48	ENABLED
7	CORE BLADE	176	CR32-8	ENABLED
8	CORE BLADE	176	CR32-8	ENABLED
9	SW BLADE	178	FC32-48	ENABLED

```

10    AP BLADE    186    SX6        ENABLED
11    SW BLADE    178    FC32-48    ENABLED
12    SW BLADE    178    FC32-48    ENABLED
switch:admin>

```

- Verify that the device is functioning correctly by entering **switchShow** or **switchStatusShow**.

This **switchShow** command displays the device and port status information.

```

switch15:admin> switchshow
switchshow>      switchshow
switchName:      sw15
switchType:      166.0
switchState:     Online
switchMode:      Native
switchRole:      Subordinate
switchDomain:     1
switchId:        fffc01
switchWwn:       10:00:00:23:f8:f2:15:82
zoning:          ON (MPR4k)
switchBeacon:    OFF
FC Router:       OFF
FC Router BB Fabric ID: 128
Address Mode:    0
Fabric Name:     BB1
HIF Mode:        OFF

```

Index	Slot	Port	Address	Media	Speed	State	Proto
0	3	0	010000	id	32G	Online	FC F-Port 20:00:00:27:f8:f3:15:80
1	3	1	010100	id	32G	Online	FC F-Port 20:01:00:27:f8:f3:15:80
2	3	2	010200	id	32G	Online	FC F-Port 20:02:00:27:f8:f3:15:80
3	3	3	010300	id	32G	Online	FC F-Port 20:03:00:27:f8:f3:15:80
4	3	4	010400	id	32G	Online	FC F-Port 20:04:00:27:f8:f3:15:80
5	3	5	010500	id	32G	Online	FC F-Port 20:05:00:27:f8:f3:15:80
6	3	6	010600	id	32G	Online	FC F-Port 20:06:00:27:f8:f3:15:80

(output truncated)

- Verify that all the IP address information is correct by entering **ipAddrShow** and checking the results against the IP information recorded in the **config-miscinfo.txt** file.

```

switch:admin> ipaddrshow
SWITCH
Ethernet IP Address: xxx.xxx.xxx.12
Ethernet Subnetmask: 255.55.0.0
Fibre Channel IP Address: 1.2.3.4
Fibre Channel Subnetmask: 255.255.255.0
CP0
Ethernet IP Address: xxx.xxx.xxx.10
Ethernet Subnetmask: 255.55.0.0
HostName : cp0
Gateway Address: xxx.xxx.xxx.1
CP1
Ethernet IP Address: xxx.xxx.xxx.11
Ethernet Subnetmask: 255.55.0.0
HostName : cp1
Gateway Address: .1
Backplane IP address of CP0 : 10.0.0.4
Backplane IP address of CP1 : 10.0.0.5
switch:admin>switch:admin>

```

Reconnecting system to the network and fabric

About this task

Complete the following steps to reconnect the device to the network and fabric.

Procedure

1. Connect the CP blades to the local area network.
 - a. Insert the appropriate Ethernet cables into each Ethernet port.
 - b. Connect the other ends to an appropriate Ethernet LAN, if not already connected.

Note: The device can be accessed by remote connection using any of the available management tools, such as Telnet or Web Tools. Ensure that the device is not modified using other connections during the rest of this procedure.

2. Reconnect the transceivers and cables to the port blades.

Note: The ports and cables used in trunking groups must meet specific requirements. For a list of these requirements, refer to the *Fabric OS Administrator's Guide*.

- a. Position one of the transceivers so that the key is oriented correctly to the port and insert the transceiver into the port until it is firmly seated and the latching mechanism clicks.
- b. Select the cable that corresponds to the port and position it so that the key (the ridge on one side of the cable connector) is aligned with the slot in the transceiver. Insert the cable into the transceiver until the latching mechanism clicks.
- c. Repeat step a and step b for the remaining ports.
- d. Organize the cables as required.

Note: Do not route cables in front of the air exhaust vents.

Verifying correct configuration of the fabric

About this task

Copying the command outputs from this section into a file is recommended. You must be logged in with Admin privileges.

Procedure

1. Create an "after" SAN profile by entering the following commands and copying the output to a text file named SANafter.txt:

- **nsShow**
- **nsAllShow**
- **switchShow**
- **fabricShow**
- **lscfg --show** (if using the Virtual Fabric feature)

```
switch:admin> nsshows
Type Pid   COS      PortName NodeName TTL(sec)
N   020f00;  3;10:00:00:01:73:00:29:46;10:00:00:01:73:00:29:46; na
      Fabric Port Name: 20:0f:00:60:69:90:03:f0
<output truncated>
switch:admin> nsallshows
{
  020f00 021fda 021fdc 021fe0 021fe1
5 Nx_Ports in the Fabric}
switch:admin> switchshows
switchName: rs18-st03-01
<output truncated>
```

```

switch:admin> fabricshow
Switch ID Worldwide Name Enet IP Addr FC IP Addr Name
<output truncated>
switch:admin>lscfg --show
Created switches: 128(ds) 1 2(bs)
Port 0 1 2 3 4 5 6 7 8 9
-----
FID 1 | 1 | 1 | 1 | 1 | 128 | 128 | 128 | 128 | 128 |
<output truncated>
switch:admin>

```

2. Determine any differences between the information in the SANafter.txt file and the information in the SANbefor.txt file created earlier. In particular, look for differences in the following:
 - Device types
 - Number of devices
 - ISL and port states
 - Number of switches in the fabric
3. Resolve any issues or unintentional changes to the device or fabric:
 - If there are any mechanical problems, try reseating the associated component.
 - If the configuration information is not correct for the device, modify as required.
 - If other issues exist, contact your support provider.

Removing the battery

CAUTION:

The battery contains lithium. To avoid possible explosion, do not burn or charge the battery. Do not:

- Throw or immerse into water
- Heat to more than 100°C (212°F)
- Repair or disassemble

Exchange only with the IBM-approved part. Recycle or discard the battery as instructed by local regulations. In the United States, IBM has a process for the collection of this battery. For information, call 1-800-426-4333. Have the IBM part number for the battery unit available when you call. (C003)

Local regulations may require removing the battery prior to disposing of or recycling this product. Complete these steps to remove the battery.

1. Disconnect all power and communication cables.
2. Remove all transceivers.
3. Remove the power supplies and fans.
4. Unscrew the fasteners and remove the sheetmetal cover from the chassis.
5. On the main circuit board, go to location **1** shown in Figure 58 on page 194 and remove the BR1225 battery from the holder.

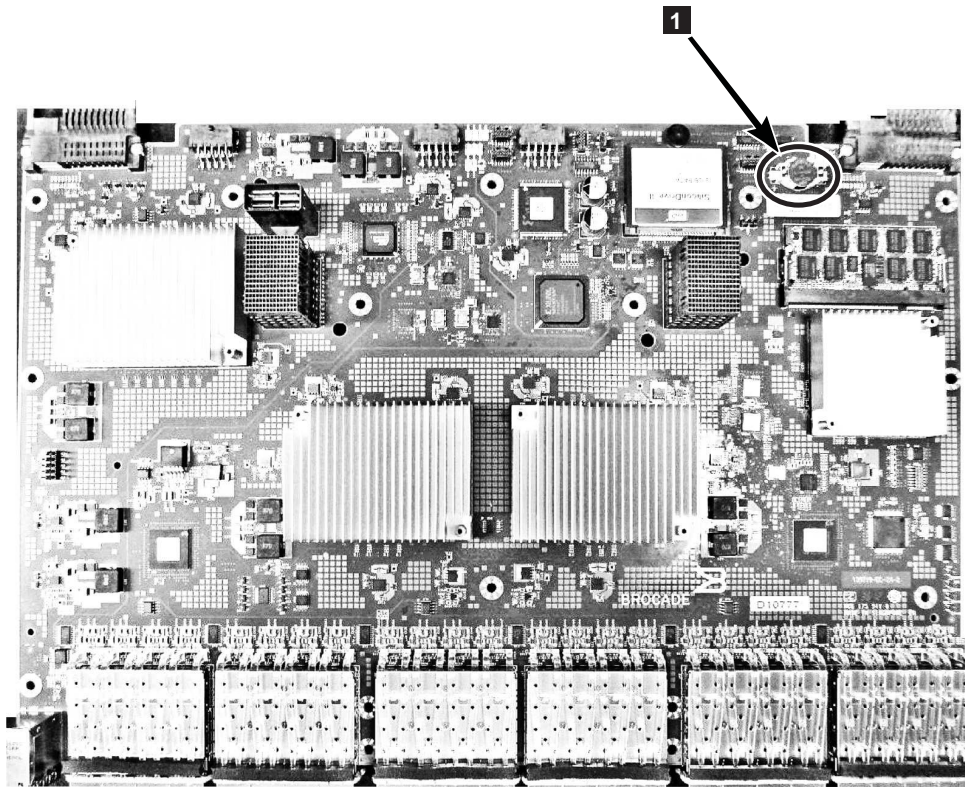

Figure 58. Location of battery holder

6. Recycle the battery as appropriate, following local regulations.

Refer to the *Environmental Notices and User Guide* shipped with the product for more information on battery recycling and disposal.

Appendix. Product specifications

This appendix provides the specifications for the switch.

- “System specifications”
- “Fibre channel” on page 198
- “LEDs” on page 198
- “Weight and physical dimensions” on page 199
- “Environmental requirements” on page 201\
- “Power supply requirements” on page 201
- “Fibre Channel data transmission ranges” on page 206
- “Data port specifications (Fibre Channel)” on page 207
- “Serial port specifications (pinout RJ-45)” on page 207
- “Memory specifications (per CP blade)” on page 208
- “Regulatory compliance (EMC)” on page 208

System specifications

System component	Description
Enclosure	SAN256B-6 - 8 blade slots, 8U rack-mountable chassis; 27–31 in. rail, 18–24 in. rail, and airflow diversion rack mount kits for four-post rack; mid-mount kit for two-post rack. SAN512B-6, 12 blade slots, 14U rack-mountable chassis; 27–31 in. and 22 in. rail kits for four-post rack; mid-mount kit for two-post rack.
Control processor	Redundant (active/standby) control processor blades
Scalability	Full fabric architecture: a maximum of 239 switches
Performance	<ul style="list-style-type: none">• 4-Gbps line speed, full duplex• 8-Gbps line speed, full duplex• 10-Gbps line speed, full duplex• 16-Gbps line speed, full duplex• 32-Gbps line speed, full duplex Autosensing of 4-, 8-,16-, and 32-Gbps port speeds depending on SFPs used. Speed matching between 4-, 8-,16-, and 32-Gbps port speeds. 10-Gbps port speeds with dedicated SFPs.

System component	Description
ICL trunking	<p>Can configure the following maximum QSFPs per trunk depending on blade type connecting:</p> <ul style="list-style-type: none"> • Up to four 4x32 Gbps QSFP ports in a trunk group can form a 512 Gbps trunk between two CR32-4 blades. For trunks containing four or fewer QSFP ports, ports in trunk must be located in the same port group on each blade. • Up to four 4x32 Gbps QSFP ports in a trunk group can form a 512-Gbps trunk between a CR32-4 and CR32-8 blade. For trunks containing four or fewer QSFP ports, ports in trunk must be located in the same port group on each blade. • Up to four 4x16 Gbps QSFP ports in a trunk group can form a 256-Gbps trunk between a CR32-X (CR32-8 or CR32-4) blade and CR16-X blade (Gen 5 CR blade). <p>Four 32 Gbps ports in a QSFP form a 128-Gbps link.</p> <p>A minimum of two QSFP connections are required for a trunk.</p>
Slot bandwidth	1,536 Gbps (data rate)
Local switching bandwidth	1.5 Tbps for FC32-48: 48 ports × 32 Gbps (data rate)
Chassis bandwidth	<p>SAN256B-6 : 8 Tbps per chassis (192 ports with 32 Gbps data rate plus 16 4x32 Gbps ICLs)</p> <p>SAN512B-6 : 16 Tbps per chassis (384 ports with 32 Gbps data rate plus 32 4x32 Gbps ICLs)</p>
ISL trunking	Can use up to 8 ports in a trunk group to form a 256-Gbps trunk.
UltraScale ICL bandwidth	<p>SAN256B-6 : 2 Tbps; 16 UltraScale ICL ports provide the equivalent of 64 32-Gbps ports. Each UltraScale ICL port provides 128-Gbps bandwidth over a QSFP (32 Gbps × 4) link.</p> <p>SAN512B-6 : 4 Tbps; 32 UltraScale ICL ports provide the equivalent of 128 32-Gbps ports. Each UltraScale ICL port provides 128 Gbps bandwidth over a QSFP (32 Gbps × 4) line.</p> <p>Both models: Frame-based trunking is enabled between four UltraScale ICLs. DPS distributes exchanges across all frame trunks.</p>
Power inlet	C20; power from non-port side.
Power supplies	<p>SAN256B-6 : Up to two modular, hot-swappable AC power supplies providing 1450 W (100-120 VAC) and 2870 W (200-240 VAC).</p> <p>SAN512B-6 : Up to four modular, hot-swappable AC power supplies providing 1450 W (100-120 VAC) and 2870 W (200-240 VAC).</p> <p>Note: Refer to "Power Supply Requirements" section of this Technical Specification for details on minimum power supplies required for operation and redundancy.</p>
Cooling	<p>SAN256B-6 : Two fan assemblies, nonport-side exhaust or intake, for 1+1 redundancy. Each assembly contains 2 fans for total of 4. System requires 3 out of 4 functioning fans for operation. One fan assembly can be hot-swapped, but must be replaced immediately.</p> <p>SAN512B-6 : Three fan assemblies, nonport-side exhaust or intake, for 2+1 redundancy. Each assembly contains 2 fans for total of 6. System requires 5 out of 6 functioning fans for operation. One fan assembly can be hot-swapped, but must be replaced immediately.</p>

System component	Description
System architecture	Nonblocking shared memory
System processors	FreeScale P4080 (8 core), 1.5 GHz
Aggregate bandwidth	SAN256B-6 : 8 Tbps when populated with 192x32 Gbps ports and using 16 ICL ports at 128 Gbps (including 2 Tbps of ICL bandwidth) SAN512B-6 : 16 Tbps when populated with 384x32 Gbps and using 32 ICL ports at 128 Gbps (including 4 Tbps of ICL bandwidth)
Switch latency	FC32-48 blade: <900ns (including FEC) any port to any port local switching and 2.7 µsec blade to blade (including FEC) at 32-Gbps, cut-through routing. SX6 blade - FC to FC: <900ns (including FEC) and 2.7 µsec any port to any port at 32 Gbps, cut-through routing.
Maximum frame size	112-byte payload
Frame buffers	15000 per CR32 core routing blade ASIC
Port types	FC32-48 port blade: F_Port, E_Port, EX_Port, M_Port, SIM, and D_Port SX6 extension blade: F_Port, FL_Port, E_Port, SIM, and EX_Port on FC, and VE_Port on GbE NOTE: Self-discovery is based on switch type (U_Port) with an optional port type control.
Data traffic types	Fabric switches supporting unicast, multicast (255 groups), and broadcast
Media types	FC32-48 port blade: supports hot-pluggable 32 Gbps SWL/LWL SFP28, 16 Gbps SWL/LWL/ELWL SFP+, 10 Gbps SWL/LWL SFP SX6 extension blade: supports hot-pluggable 32 Gbps SWL/LWL SFP28, 16 Gbps SWL/LWL/ELWL SFP+, 10 Gbps SWL/LWL SFP, 1 GbE copper SFP, 1GbE 1000Base-SX/LX/CWDM SFP, 10 GbE SR/LR SFP+; 10 GbE Tunable DWDM 80km SFP+, and 40 GbE SR4/LR4/ER4 QSFP. Core routing blade CR32-4 and CR32-8: support -branded, hot-pluggable 4x32 Gbps SWL QSFP, 4x16 Gbps SWL QSFP, 4x16 Gbps 2km LWL QSFP for ICL connections
USB	One USB port per control processor for firmware download, support save, and configuration upload or download
Fabric services	Advanced Performance Monitoring; Adaptive Networking (Ingress Rate Limiting, Traffic Isolation, QoS); BB credit recovery; Advanced Zoning (default zoning, port/WWN zoning, broadcast zoning); Dynamic Path Selection (DPS); Extended Fabrics; Fabric Vision; FDMI; FICON CUP; Frame Redirection; FSPF; Integrated Integrated Routing; IPFC; ISL Trunking; Management Server; N_Port Trunking; NPIV; NTP v3; Port Fencing; Registered State Change Notification (RSCN); Reliable Commit Service (RCS); Simple Name Server (SNS); syslog; Flow Vison; Virtual Fabrics (Logical Switch, Logical Fabric); target-driven zoning; peer zoning

System component	Description
Extension	Supports DWDM, CWDM, and FC-SONET devices; Fibre Channel, in-flight compression (LZO) BB credit recovery; Extension trunking, FICON Extension, IP Extension, Adaptive Rate Limiting (ARL), data compression, Fast Write, read/write Tape Pipelining, QoS
FICON	FICON cascading; support for lossless DLS; FICON CUP; Advanced Accelerator for FICON (IBM z/OS Global Mirror and read/write Tape Pipelining)
Inter-chassis link (ICL)	Chassis-to-chassis linkage through connectors on the core routing (CR) blade

Fibre channel

System component	Description
Fibre Channel ports	SAN256B-6 : Up to 192 32-Gbps ports, universal (F_Port, E_Port, EX_Port, M_Port, D_Port, FICON) SAN512B-6 : Up to 384 32-Gbps ports, universal (E_Port, F_Port, EX_Port, M_Port, D_Port, FICON)
Classes of service	Class 2, Class 3, Class F (interswitch frames)
ANSI Fibre Channel protocol	FC-PH (Fibre Channel Physical and Signalling Interface standard)
Fabric initialization	Complies with FC-SW 5.0
IP Extension (IP over Fibre Channel)	Complies with FC-IP 2.3 of the FCA profile
Port to port latency	Local switching - 900 ns (including FEC) any port to any port; Blade to blade - 2.7 microseconds (including FEC) E_Port to E_Port
Switching capacity	An aggregate switching capacity of 13.5 billion frames per second (for Class 2, Class 3, and Class F frames for a 384-port chassis)

LEDs

System component	Description
Port status	Bicolor (green and amber) Fibre Channel port status LED on port blades displaying nine different LED states based on FC port activity and status. Bicolor (green and amber) QSFP ICL port LED on core routing blades displaying four different states based on activity and status of all four lanes. Bicolor (green and amber) Fibre Channel port status on extension blades displaying eight different LED states based on port activity and status. Bicolor (green and amber) Ethernet port status on extension blades displaying four different LED states based on port activity and status.
Blade power and status	Unicolor (green) displaying power off and power on condition. Unicolor (amber) LED displaying four different LED states based on blade operation.

System component	Description
CP blade status	<p>Unicolor (green) Ethernet link status displaying two different states depending on link operation.</p> <p>Unicolor (green) Ethernet link activity displaying two different states depending on link operation.</p> <p>Unicolor (blue) control processor (CP) displaying two different states depending on active or standby status.</p> <p>Unicolor (bright white) illuminates to indicate blade location (beacon).</p>
WWN card status	<p>Unicolor (green) displaying power off and power on condition.</p> <p>Unicolor (amber) fault LED.</p>
Fan status	<p>Unicolor (green) displaying power off and power on condition.</p> <p>Unicolor (amber) status LED displaying four different LED states based on fan operation.</p>
Power supply status	Unicolor (green) power status LED displaying eight different LED states based on power supply operation.

Other

System component	Description
Serial Cable	RS-232 serial cable
RJ-45 to DB9 adaptor	RS-232 cable has an adapter at one end that can be removed to provide an RJ-45 style connector. For serial port.
RJ-45 connector	For 10 Gbps and 10/100/1000 Ethernet management ports per control processor

Weight and physical dimensions

Model	Height	Width	Depth	Weight (empty)	Weight (fully loaded)
SAN512B-6	61.23 cm	43.74 cm	61.05 cm	35.61 kg	145.83 kg
	24.11 inches	17.23 inches	24.04 inches	78.5 lb	321.5 lb
SAN512B-6 with door	61.23 cm	43.74 cm	72.96 cm		Weight includes all blades and four power supplies.
	24.11 inches	17.23 inches	28.72 inches		

Model	Height	Width	Depth	Weight (empty)	Weight (fully loaded)
SAN256B-6	34.45 cm 13.56 inches	43.74 cm 17.23 inches	61.04 cm 24.04 inches	24.49 kg 54 lb	68.95 kg 152.0 lb Weight includes all blades and two power supplies.
SAN256B-6 with Airflow Diverter and Port Side Exhaust Kit	40.00 cm 15.75 inches	43.74 cm 17.22 inches	61.29 cm 24.09 inches		
SAN256B-6 with door	34.45 cm 13.56 inches	43.74 cm 17.23 inches	73.20 cm 28.82 inches		

Blade	Description	Length	Depth	Height	Weight
CPX6 blade	Control processor blade	20.55 cm 8.09 inches	34.46 cm 13.57 inches	3.28 cm 1.29 inches	1.93 cm 4.25 inches
CR32-4 blade (without media)	Core routing blade for SAN256B-6	42.06 cm 16.56 inches	34.13 cm 13.44 inches	3.63 cm 1.43 inches	3.92 kg 8.65 lb
CR32-8 blade (without media)	Core routing blade for SAN512B-6	42.06 cm 16.56 inches	34.13 cm 13.44 inches	3.63 cm 1.43 inches	4.87 kg 10.75 lb
FC32-48 port blade (without media)	48-port port blade supporting 4/8/10/16/32 Gbps	42.06 cm 16.56 inches	34.13 cm 13.44 inches	3.63 cm 1.43 inches	4.35 kg 9.6 lb
SX6 extension blade (without media)	Enables FC extension functionality over existing IP infrastructure. Has 16 FC ports supporting 8/10/16/32 Gbps, 16 GbE ports supporting 1 or 10 Gbps, and two GbE ports supporting 40 Gbps.	42.06 cm 16.56 inches	34.13 cm 13.44 inches	3.63 cm 1.43 inches	5.22 kg 11.5 lb

Environmental requirements

Condition	Operational	Non-operational (storage)
Ambient temperature	0°C to 40°C (32°F to 104°F)	-25°C to 70°C (-13°F to 158°F)
Relative humidity (non-condensing)	5% to 93% at 40°C (104°F) with maximum gradient of 10% per hour	10% to 93% at 70°C (158°F)
Altitude (above sea level)	0 to 3000 m (10,000 feet)	0 to 12000 m (40,000 feet)
Shock	10 G, 11 ms, half-sine wave	20 G, 11 ms, half-sine wave
Vibration	Random vibration is 5-10Hz @ +5db/Oct; 10-200Hz @ 0.0005Grms; 200-500Hz @ -5db/Oct. Scale 0.05 Grms	Random Vibration is 3-10Hz @ +5db/Oct; 10-200Hz @ 0.0065Grms; 200-500Hz @ -5db/Oct. Scale 1.12 Grms
Air flow	SAN512B-6 Maximum: 1711 cmh (1007 cfm) SAN512B-6 Nominal: ~985 cmh (~580 cfm) SAN256B-6 Maximum: 953 cmh (561 cfm) SAN256B-6 Nominal: ~ 486 cmh (~286 cfm)	N/A
Heat dissipation	SAN256B-6 - refer to Watts and Btu/hr values under VAC inputs in Typical, Idle, and Maximum Power Consumption tables. SAN512B-6- refer to Watts and Btu/hr values under VAC inputs in Typical, Idle, and Maximum Power Consumption tables.	N/A
Operating noise	SAN256B-6: 64.2 dB SAN512B-6: 68.2 dB	N/A

Power supply requirements

The minimum number of power supplies needed in your system for operation and to achieve redundancy depends on the blade and port configuration and the AC input voltage level. N is minimum number of power supplies to operate configuration, N+N doubles power supplies for full AC input and DC output redundancy, and N+1 adds additional power supply for DC output redundancy in case of single power supply failure. Although examples for different port and blade configurations are provided, for more information and help with determining the actual number of power supplies for your deployment, contact your local representative.

Model name	Configured ports	AC connection	Minimum power supplies for operation	Number of power supplies (redundancy)
SAN256B-6	Any combination of 32 Gbps ports, Extension blades, and QSFP ICLs	100–120 VAC (low line)	2	Not supported
		200–240 VAC (high line)	1	2 (N+N)
SAN512B-6	144 32 Gbps ports and QSFP ICLs	100–120 VAC (low line)	2	3 (N+1)
		100–120 VAC (low line)	2	4 (N+N)
		200–240 VAC (high line)	1	2 (N+N)
SAN512B-6	384 32 Gbps ports and QSFP ICLs	100–120 VAC (low line)	3	Not supported
		200–240 VAC (high line)	2	3 (N+1)
		200–240 VAC (high line)	2	4 (N+N)
SAN512B-6	Any combination of 32 Gbps ports, Extension blades, and QSFP ICLs	100–120 VAC (low line)	3	Not supported
		200–240 VAC (high line)	2	3 (N+1)
		200–240 VAC (high line)	2	4 (N+N)

Power supply specifications (per PSU)

Power supply model	Maximum output power rating (DC)	Input voltage	Input line frequency	Maximum input current	Input line protection	Maximum inrush current
XBR-X6-RACNPIPSU-0104	1450/2870 W	1450 W Output 100–120 V (nominal)	50–60 Hz (nominal)	15 A	Line & Neutral Fused	35 A peak for <10 ms at cold or warm start
XBR-X6-RACNPEPSU-0104		90–132 V (range)				2870 W Output 200–240 V (nominal)
		180–264 V (range)				Less than fuse rating for >150ms

Power consumption (typical configuration)

The typical power consumption configuration features fans at nominal speed and the FC32-48 port blade configured with optics operating at 50% line rate and random packets (does not include the power draw for the SX6 extension blade).

Model name	@100 VAC input	@200 VAC input	@-48 VDC input	Minimum number of power supplies	Notes
SAN256B-6	1407 W 4802 BTU/hr	1376 W 4696 BTU/hr	Not supported	2 power supplies for AC low Line (100–120 VAC) 1 power supply for AC high line (200–240 VAC) Device ships with 2 power supplies. One provides system power, but both must be installed to provide power efficiency and redundancy.	SAN256B-6 fully loaded: 2 CP blades, 2 CR blades, 4 FC32-48 port blades, 2 fan assemblies
SAN512B-6	2647 W 9034 BTU/hr	2589 W 8836 BTU/hr	Not supported	3 power supplies for AC low line (100–120 VAC) 2 power supplies for AC high line (200–240 VAC) Device ships with 3 or 4 power supplies. Two provide system power, but 3 or 4 must be installed to provide power efficiency and redundancy.	SAN512B-6 fully loaded: 2 CP blades, 2 CR blades, 8 FC32-48 blades, 3 fan assemblies

Power consumption (idle configuration)

No optics or connections, ports disabled, and system completed boot up, fans at low speed.

Model name	@100 VAC input	@200 VAC input	@-48 VDC input	Minimum number of power supplies	Notes
SAN256B-6	840 W 2867 BTU/hr	822 W 2806 BTU/hr	Not supported	2 power supplies for AC low line (100–120 VAC) 1 power supply for AC high line (200–240 VAC) Device ships with 2 power supplies. One provides system power, but both must be installed to provide power efficiency and redundancy.	SAN256B-6 fully loaded: 2 CP blades, 2 CR blades, 4 FC32-48 port blades, 2 fan assemblies
SAN512B-6	1515 W 5171 BTU/hr	1481 W 5055 BTU/hr	Not supported	3 power supplies for AC low line (100–120 VAC) 2 power supplies for AC high line (200–240 VAC) Device ships with 3 or 4 power supplies. Two provide system power, but 3 or 4 must be installed to provide power efficiency and redundancy.	SAN512B-6 fully loaded: 2 CP blades, 2 CR blades, 8 FC32-48 blades, 3 fan assemblies

Power consumption (maximum configuration)

The maximum power consumption configuration features fans at maximum speed and the FC32-48 blade installed with optics. Traffic is at full-line rate, smallest packet is 64-bytes, 40°C (104°F) ambient temperature, and maximum power for all supported optics. Does not include the power draw for the SX6 extension blade.

Model name	@100 VAC input	@200 VAC input	@-48 VDC input	Minimum number of power supplies	Notes
SAN256B-6	2438 W 8322 BTU/hr	2385 W 8139 BTU/hr	N/A	2 for AC low line (100–120 VAC) 1 for AC high line (200–240 VAC) Device ships with 2 power supplies. One provides system power, but both must be installed to provide power efficiency and redundancy.	SAN256B-6 fully loaded: 2 CP blades, 2 CR blades, 4 FC32-48 port blades, 2 fan assemblies
SAN512B-6	4339 W 14810 BTU/hr	4244 W 14485 BTU/hr	N/A	3 for AC low line (100–120 VAC) 2 for AC high line (200–240 VAC) Device ships with 3 or 4 power supplies. Two provide system power, but 3 or 4 must be installed to provide power efficiency and redundancy	SAN512B-6 fully loaded: 2 CP blades, 2 CR blades, 8 FC32-48 blades, 3 fan assemblies

Power consumption (modules)

For blades in the following table:

- Idle: blade enabled, chips initialized, no optics, ports disabled.
- Nominal: blade enabled, optics in 50% of ports, passing line rate.

- Maximum: blade enabled, optics installed, traffic, full-line rate, 64-byte smallest packet, 40°C (104°F) ambient temperature, maximum power for all supported optics.

Module name	Module description	Power consumption
CPX6	Control Processor Blade	Idle = 38 W Typical = 45 W Maximum = 50 W
CR32-4	Core Routing Blade for SAN256B-6	Idle = 95 W Typical = 160 W Maximum = 244 W
CR32-8	Core Routing Blade for SAN512B-6	Idle = 180 W Typical = 342 W Maximum = 450 W
SX6	Extension Blade	Idle = 300 W Typical = 340 W Maximum = 420 W
FC32-48	48 x 32 Gbps Port Blade	Idle = 95 W Typical = 160 W Maximum = 245 W
WWN card	World Wide Name card	Idle = 1 W Typical = 1 W Maximum = 1 W
Fan assembly	Fan assembly contains two fans	Idle = 50 W Nominal = 100 W Maximum = 300 W

Fibre Channel data transmission ranges

Port speed (Gbps)	Cable size (microns)	Short wavelength (SWL)	Long wavelength (LWL)	Extended long wavelength (ELWL)
4	50	150 m (492 ft) (OM2)	N/A	N/A
		380 m (1,264 ft) (OM3)		
		400 m (1,312 ft) (OM4)		
62.5	62.5	70 m (229 ft)	N/A	N/A
		N/A		
9	9	N/A	30 km (18.6 miles)	N/A

Port speed (Gbps)	Cable size (microns)	Short wavelength (SWL)	Long wavelength (LWL)	Extended long wavelength (ELWL)
8	50	50 m (164 ft) (OM2)	N/A	N/A
		150 m (492 ft) (OM3)		
		190 m (623 ft) (OM4)		
	62.5	21 m (68 ft)	N/A	N/A
	9	N/A	10 km (6.2 miles)	N/A
10	50	82 m (269 ft) (OM2)	N/A	N/A
		300 m (984 ft) (OM3)		
		550 m (1,804 ft) (OM4)		
	62.5	33 m (108 ft)	N/A	N/A
	9	N/A	10 km (6.2 miles)	N/A
16	50	35 m (115 ft) (OM2)	N/A	N/A
		100 m (328 ft) (OM3)		
		125 m (410 ft) (OM4)		
	62.5	15 m (49 ft)	N/A	N/A
	9	N/A	10 km (6.2 miles)	N/A
32	50	10 m (32.8 ft) (OM2)	N/A	N/A
		70 m (230 ft) (OM3)		
		100 m (328 ft) (OM4)		
	62.5	10 m (32.8 ft)	N/A	N/A
	9	100 m (328 ft)	10 km (6.2 miles)	N/A

Data port specifications (Fibre Channel)

Name	Number of ports	Description
SAN256B-6	192	32 Gbps (E, F, D, M, and EX) Fibre Channel ports using four 48-port 32 Gbps Fibre Channel port blades.
SAN512B-6	384	32 Gbps (E, F, D, M, and EX) Fibre Channel ports using four 48-port 32 Gbps Fibre Channel port blades.

Serial port specifications (pinout RJ-45)

Pin	Signal	Description
1	Not supported	NA
2	Not supported	NA
3	UART1_RXD	Transmit data
4	GND	Logic ground
5	GND	Logic ground

Pin	Signal	Description
6	UART1_TXD	Receive data
7	Not supported	NA
8	Not supported	NA

Serial port specifications (protocol)

Parameter	Value
Baud	9600
Data bits	8
Parity	None
Flow control	None Note: Flow control on customer terminal servers.

Memory specifications (per CP blade)

Memory	Type	Size
Main memory	DDR3 MiniDIMM	16 GB
Boot flash	On-board NAND	4 MB
Compact flash	eUSB	16 GB

Regulatory compliance (EMC)

- FCC Part 15, Subpart B (Class A)
- EN 55022 (CE mark) (Class A)
- EN 55024 (CE mark) (Immunity) for Information Technology Equipment
- ICES-003 (Canada) (Class A)
- AS/NZ 55022 (Australia) (Class A)
- VCCI (Japan) (Class A)
- EN 61000-3-2
- EN 61000-3-3
- EN 61000-6-1

Regulatory compliance (safety)

- CAN/CSA-C22.2 No. 60950/UL 60950
- EN 60825 Safety of Laser Products
- EN 60950/IEC 60950 Safety of Information Technology Equipment

Regulatory compliance (environmental)

- 2014/35/EU and 2014/30/EU
- 2011/65/EU - Restriction of the use of certain hazardous substance in electrical and electronic equipment (EU RoHS).
- 2012/19/EU - Waste electrical and electronic equipment (EU WEEE).
- 94/62/EC - packaging and packaging waste (EU).
- 2006/66/EC - batteries and accumulators and waste batteries and accumulators (EU battery directive).

- 1907/2006 of the European Parliament and of the Council of 18 December 2006 concerning the Registration, Evaluation, Authorisation and Restriction of Chemicals (EU REACH).
- Section 1502 of the Dodd-Frank Wall Street Reform and Consumer Protection Act of 2010 - U.S. Conflict Minerals.
- 30/2011/TT-BCT - Vietnam circular.
- SJ/T 11363-2006 Requirements for Concentration Limits for Certain Hazardous Substances in EIPs (China).
- SJ/T 11364-2006 Marking for the Control of Pollution Caused by EIPs (China).

Notices

This information was developed for products and services offered in the USA.

IBM may not offer the products, services, or features discussed in this document in other countries. Consult your local IBM representative for information on the products and services currently available in your area. Any reference to an IBM product, program, or service is not intended to state or imply that only that IBM product, program, or service may be used. Any functionally equivalent product, program, or service that does not infringe on any IBM intellectual property right may be used instead. However, it is the user's responsibility to evaluate and verify the operation of any non-IBM product, program, or service.

IBM may have patents or pending patent applications covering subject matter described in this document. The furnishing of this document does not give you any license to these patents. You can send license inquiries, in writing to:

*IBM Director of Licensing
IBM Corporation
North Castle Drive
Armonk, N.Y. 10504-1785
U.S.A.*

For additional information, visit the web at: www.ibm.com/ibm/licensing/contact/

The following paragraph does not apply to the United Kingdom or any other country where such provisions are inconsistent with local law:

INTERNATIONAL BUSINESS MACHINES CORPORATION PROVIDES THIS PUBLICATION "AS IS" WITHOUT WARRANTY OF ANY KIND, EITHER EXPRESS OR IMPLIED, INCLUDING, BUT NOT LIMITED TO, THE IMPLIED WARRANTIES OF NON-INFRINGEMENT, MERCHANTABILITY OR FITNESS FOR A PARTICULAR PURPOSE. Some states do not allow disclaimer of express or implied warranties in certain transactions, therefore, this statement may not apply to you.

This information could include technical inaccuracies or typographical errors. Changes are periodically made to the information herein; these changes will be incorporated in new editions of the publication. IBM may make improvements and/or changes in the product(s) and/or the program(s) described in this publication at any time without notice.

Any references in this information to non-IBM web sites are provided for convenience only and do not in any manner serve as an endorsement of those web sites. The materials at those web sites are not part of the materials for this IBM product and use of those web sites is at your own risk.

IBM may use or distribute any of the information you supply in any way it believes appropriate without incurring any obligation to you.

Any performance data contained herein was determined in a controlled environment. Therefore, the results obtained in other operating environments may vary significantly. Some measurements may have been made on development-level

systems and there is no guarantee that these measurements will be the same on generally available systems. Furthermore, some measurement may have been estimated through extrapolation. Actual results may vary. Users of this document should verify the applicable data for their specific environment.

Information concerning non-IBM products was obtained from the suppliers of those products, their published announcements or other publicly available sources. IBM has not tested those products and cannot confirm the accuracy of performance, compatibility or any other claims related to non-IBM products. Questions on the capabilities of non-IBM products should be addressed to the suppliers of those products.

If you are viewing this information in softcopy, the photographs and color illustrations may not appear.

Trademarks

IBM, the IBM logo, and ibm.com[®] are trademarks or registered trademarks of International Business Machines Corp., registered in many jurisdictions worldwide. Other product and service names might be trademarks of IBM or other companies. A current list of IBM trademarks is available on the web at Copyright and trademark information at www.ibm.com/legal/copytrade.shtml

Adobe, the Adobe logo, PostScript, and the PostScript logo are either registered trademarks or trademarks of Adobe Systems Incorporated in the United States, and/or other countries.

Java[™] and all Java-based trademarks and logos are trademarks or registered trademarks of Oracle and/or its affiliates.

Linux is a registered trademark of Linus Torvalds in the United States, other countries, or both.

Microsoft, Windows, Windows NT, and the Windows logo are trademarks of Microsoft Corporation in the United States, other countries, or both.

UNIX is a registered trademark of The Open Group in the United States and other countries.

Other product and service names might be trademarks of IBM or other companies.

Homologation statement

This product may not be certified in your country for connection by any means whatsoever to interfaces of public telecommunications networks. Further certification may be required by law prior to making any such connection. Contact an IBM representative of reseller for any questions.

Electronic emission notices

This section contains the electronic emission notices or statements for the United States and other countries.

BSMI statement (Taiwan)

警告使用者：
這是甲類的資訊產品，在居住的環境中使用時，可能會造成射頻干擾，
在這種情況下，使用者會被要求採取某些適當的對策。

Warning:

This is Class A product. In a domestic environment this product may cause radio interference in which case the user may be required to take adequate measures.

Canadian requirements

This Class A digital apparatus meets all requirements of the Canadian Interference-Causing Equipment Regulations, ICES-003 Class A.

Cet appareil numérique de la classe A est conforme à la norme NMB-003 du Canada.

CE statement

Attention: This is a Class A product. In a domestic environment, this product might cause radio interference, and the user might be required to take corrective measures.

The standards compliance label on this device contains the CE mark which indicates that this system conforms to the provisions of the following European Council directives, laws, and standards:

- Electromagnetic Compatibility (EMC) Directive 2004/108/EEC
- Low Voltage Directive (LVD) 2006/95/EC
- EN50082-2/EN55024:1998 (European Immunity Requirements)
 - EN61000-3-2/JEIDA (European and Japanese Harmonics Spec)
 - EN61000-3-3

China ROHS

Refer to the latest revision of the China ROHS document (P/N 53Δ1000428Δxx) which ships with the product.

FCC warning (US only)

This equipment has been tested and complies with the limits for a Class A computing device pursuant to Part 15 of the FCC Rules. These limits are designed to provide reasonable protection against harmful interference when the equipment is operated in a commercial environment.

This equipment generates, uses, and can radiate radio frequency energy, and if not installed and used in accordance with the instruction manual, might cause harmful interference to radio communications. Operation of this equipment in a residential area is likely to cause harmful interference, in which case the user will be required to correct the interference at the user's own expense.

KCC statement (Republic of Korea)

A급 기기(업무용 방송통신기기): 이 기기는 업무용(A급)으로 전자파적합등록을 한 기기이오니 판매자 또는 사용자는 이 점을 주의하시기 바라며, 가정외의 지역에서 사용하는 것을 목적으로 합니다.

Class A device (Broadcasting Communication Device for Office Use): This device obtained EMC registration for office use (Class A), and may be used in places other than home. Sellers and/or users need to take note of this.

VCCI statement

この装置は、クラスA情報技術装置です。この装置を家庭環境で使用すると電波妨害を引き起こすことがあります。この場合には使用者が適切な対策を講ずるよう要求されることがあります。 VCCI-A

This is a Class A product based on the standard of the Voluntary Control Council for Interference by Information Technology Equipment (VCCI). If this equipment is used in a domestic environment, radio disturbance might arise. When such trouble occurs, the user might be required to take corrective actions.

Germany statement

Machine noise information regulation - 3. GPSGV, the highest sound pressure level value is 64.2 dB(A) in accordance with EN ISO 7779.

Maschinenlärminformations-Verordnung - 3. GPSGV, der höchste Schalldruckpegel beträgt 64.2 dB(A) gemäss EN ISO 7779.

Index

A

about this document xxv
accessibility xi
 features xi
address
 IBM xii
attention notices xx

B

battery
 disposal 193
 location 193
 recycling 193
 removal 193
boot results, interpreting 76
Brocade
 documents xxv
 equivalent product models xxvi
BSMI statement (Taiwan) 213

C

Canadian requirements 213
CE statement 213
chassis hardware components 2
chassis, replacing 180
command
 date 42
 frureplace 142
 ipaddrSet 39
 ipaddrSet -chassis 39
 ipaddrSet -cp0 39
 ipaddrSet -cp1 39
 switchName 44
 sysShutdown 48
 time zone 43
commandipaddrSetcommand
 ipAddrShow 39
comments
 sending to IBM xii
configuring IP address 39
core switch blade
 replacing 117
CP blade
 verifying operation 129
CR blade
 determining status 103, 114
 removing 115
customizing
 switch name 44

D

data transmission ranges 195
date command 42
date, setting 42
diagnostic tests 95

diagnostics
 boot results 76
 POST 76
director of licensing, address 211
documentation xxv
 Brocade xxv
 Fabric Operating System (FOS) xxv
 updates xxv

E

electrostatic discharge
 precautions xxi
environmental
 notices xv, xxiii
 product recycling and disposal xxiii
environmental requirements
 battery 193
ESD
 precautions xxi
Ethernet, establish connection 41

F

Fabric Operating System (FOS)
 documents xxv
Fabric OS
 documentation
 updates xi
 Release Notes xi
 updates xi
Fabric OS version xxv
FCC warning (US only) 213
field-replaceable units
 See FRUs 2
filler panel, replacing 169
firmwareDownload
 from USB 131
frureplace command 142
FRUs 50
 chassis
 replacing 180
 filler panel, replacing 169
 transceivers and cables, replacing 49

G

getting help xi

H

help xi

I

IBM
 address xii
 notices 211
 trademarks 212

IBM contacts xi
IBM Publications Center xi, xxv
IBM Support Portal xi, xxv
ICL
 installing 50
installation tasks 11
intellectual property 211
intended audience xxv
inter-chassis linking (QSFP) 50
IP address, configuring 39
ipaddrSet -chassiscommand 39
ipaddrSet -cp0command 39
ipaddrSet -cp1command 39
ipAddrShowcommand 39

L

labels
 safety xix
license, for patents 211

M

memory
 specifications 195

N

notices
 attention xx
 environmental xv, xxiii
 general 211
 IBM 211
 patents 211
 safety xv
 types xv

P

patents 211
POST, interpreting 76
power supply
 specifications 195
power, providing 37
precautions
 ESD xxi
 rack installation xxi
 rack relocation xxi
product
 accessibility xi
 documentation xxv
 models xxv
 specifications 195
 support xi
product disposal xxiii
product models
 Brocade xxvi
 IBM xxvi
product recycling xxiii

- product specifications
 - FC port 195
 - memory 195
 - physical dimensions 195
 - power supply 195
 - serial port 195
 - weight 195
- providing feedback xii
- publication
 - feedback xii

Q

- QSFP transceivers 50

R

- rack
 - safety precautions xxi
- rack relocation
 - safety xxiii
- read this first xi
- recycle
 - battery 193
- Redbooks xi
- removal
 - battery 193
- RRP
 - blade filler panel 169
 - chassis 180
 - QSFP cables 50
 - transceivers 49

S

- safety
 - notices xv
 - rack installation xxi
 - rack relocation xxiii
- safety labels xix
- serial connection
 - establishing 38
- support xi
- switch
 - documentation xxv
- switch name
 - customizing 44
 - length 44
- switchName command 44
- sysShutdown command 48

T

- tasks, installation 11
- terminal emulator, configuring 38
- time zone command 43
- time zone, setting 43
- tool, extraction, transceivers 49
- trademarks 212
- transceivers
 - extraction tool 49
 - QSFP 50
- transceivers and cables
 - replacing 49

V

- VCCI statement 214
- verifying, CP blade operation 129

W

- Web sites xi
- WWN card
 - preparing for replacement 142
- WWN card hot-swap replacement 143
- WWN card power-down
 - replacement 144



Part Number: 01AD458

Printed in USA

SC27-8966-00



(1P) P/N: 01AD458

